

LT2–B875 Mark II

**Twin Needle Needle Feed Split Needle
Bar Lock stitcher with Large Hook
(and Thread Trimmer)**

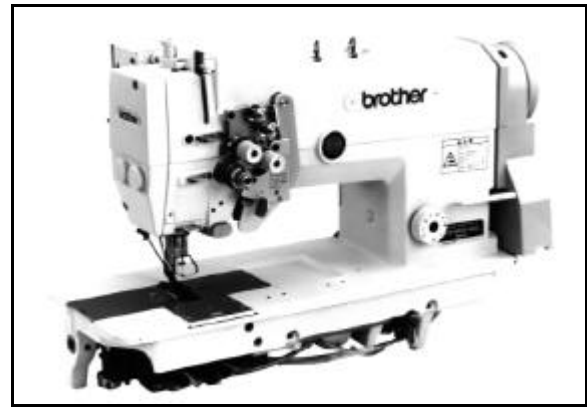

Specifications

	-3	-5	-7
Application	For medium materials	For heavy materials	For extra heavy materials
Max. speed	3,000 rpm		
Max. stitch length	7 mm		
Needle bar stroke	33.4 mm		
Thread take-up stroke	64.6 mm		
Height of presser foot	Manual	7 mm	
	Knee	13 mm (With thread wiper : 10 mm)	
	Auto-presser bar lifter	8 mm	
Height of feed dog	1 mm		
Needles	DP×5#14–#22		DP×17 #22
Hook	Horizontal large rotary hook (vertical axis)		
Needle feed mechanism	Standard		
Single needled stop device	Standard		

	-400	-900·-900S
Thread trimmer	Scissors type (Solenoid)	
Thread wiper	Solenoid type	
Quick reverse	Solenoid type	
Automatic presser bar lifter	–	Solenoid type

bro rom
INDUSTRIAL MACHINES

Str. Fabrica de Glucoza 2-4, sector 2, Bucuresti, Romania
Tel./Fax: +01 2323.844, +01 232.969, +01 2323.87
www.brother.ro www.brorom.ro mail:office@brother.ro
www.pieseschimb.masinidecusut.ro

LT2–B8750 Mark II

Twin Needle Needle Feed Split Needle Bar Lock
Stitcher, Large Hook and Thread
Trimmer Ply Sensor



Specifications

	-903	-905	-907
Application	For medium materials	For heavy materials	For extra heavy materials
Max. speed	3,000 rpm		
Max. stitch length	7 mm		
Auto-presser bar lifter	8 mm		
Needles	DP×5#14	DP×5#22	DP×17#22
Hook	Horizontal large rotary hook (vertical axis)		
Thread trimmer	Scissors type (Solenoid)		
Thread wiper	Solenoid type		
Quick reverse	Solenoid type		
Automatic presser bar lifter	Solenoid type		



B875 Mark II (For Standard)

For normal

*The specification with a maximum stitch width of 5/8" (15.9mm) is available.

*The ○ symbol is a presser foot assembly with finger guard.

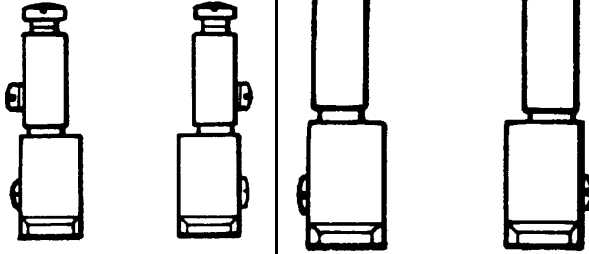
Needle gauge (inch) (mm)	Needle clamp set	Needle clamp assy	For medium & heavy materials (-3, -5)		
			Needle plate	Feed dog	Presser foot assy
1/8 (3.2)	L:S15711-001 R:S15712-001	L:S15713-001 R:S15714-001	117369-001	114951-001	155463-001
5/32 (4.0)	L:S15717-001 R:S15718-001	L:S15719-001 R:S15720-001	150850-001	116509-001	155455-001
3/16 (4.8)	L:S15723-001 R:S15724-001	L:S15725-001 R:S15726-001	117133-001	112659-001	155457-001 S36564-001 ○
1/4 (6.4)	L:S15735-001 R:S15736-001	L:S15737-001 R:S15738-001	117367-001	112660-001	155453-001 S36566-001 ○
5/16 (7.9)	L:S15747-001 R:S15748-001	L:S15749-001 R:S15750-001	144882-001	112661-001	155459-001
3/8 (9.5)	L:S15753-001 R:S15754-001	L:S15755-001 R:S15756-001	144881-101	116510-101	155461-001
1/2 (12.7)	L:S15765-001 R:S15766-001	L:S15767-001 R:S15768-001	S09365-001	116511-001	S09367-101 ○
5/8 (15.9)	L:S15771-001 R:S15772-001	L:S15773-001 R:S15774-001	159577-001	116512-001	159575-101 ○

Needle clamp set	Needle clamp assy	Needle plate	Feed dog
		(-3, -5) For medium & heavy materials	
		Presser foot assy (-3, -5) For medium & heavy materials	
			

B875 Mark II (For Standard)

(-7) : For extra heavy materials

*The feed dog is different from normal parts.

*The ○ symbol is a presser foot assembly with finger guard.

Needle gauge (inch) (mm)	Needle clamp set	Needle clamp assy	Needle plate	Feed dog	Presser foot assy
1/8 (3.2)	L:S15711-001 R:S15712-001	L:S15713-001 R:S15714-001	117369-001	158430-001	155463-001
3/16 (4.8)	L:S15723-001 R:S15724-001	L:S15725-001 R:S15726-001	117133-001	S13588-001	155457-001 S36564-001 ○
1/4 (6.4)	L:S15735-001 R:S15736-001	L:S15737-001 R:S15738-001	117367-001	153882-001	155453-001 S36566-001 ○
3/8 (9.5)	L:S15753-001 R:S15754-001	L:S15755-001 R:S15756-001	144881-101	153887-001	155461-001
1/2 (12.7)	L:S15765-001 R:S15766-001	L:S15767-001 R:S15768-001	S09365-001	153892-001	S09367-101 ○
5/8 (15.9)	L:S15771-001 R:S15772-001	L:S15773-001 R:S15774-001	159577-001	153897-001	159575-101 ○

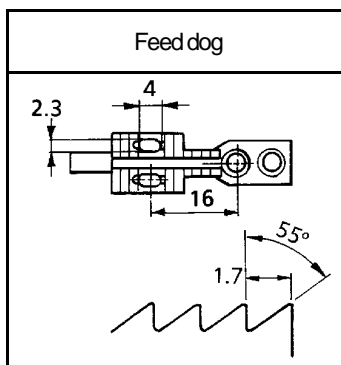

(-6) : For heavy materials

*-6 (for heavy materials) is a specification between -5 (for heavy materials) and -7 (for extra heavy materials).

*The feed dog is different from normal parts.

*The ○ symbol is a presser foot assembly with finger guard.

Needle gauge (inch) (mm)	Needle clamp set	Needle clamp assy	Needle plate	Feed dog	Presser foot assy
3/16 (4.8)	L:S15723-001 R:S15724-001	L:S15725-001 R:S15726-001	117133-001	S21149-001	155457-001 S36564-001 ○
1/4 (6.4)	L:S15735-001 R:S15736-001	L:S15737-001 R:S15738-001	117367-001	S21150-001	155453-001 S36566-001 ○

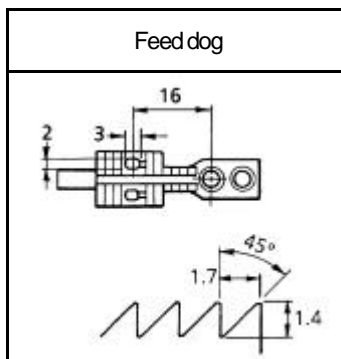

B875 Mark II (For Thread trimmer)



For normal

*The thread trimming fixed knife (part No. S07527-001) and the installation screw (part No. 148539-101) are not provided with the needle plate, so they must be ordered separately if required.

*The specification with a maximum stitch width of 5/8" (15.9 mm) is available.

*The ○ symbol is a presser foot assembly with finger guard.

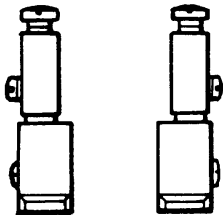
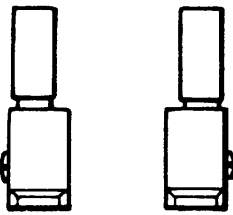
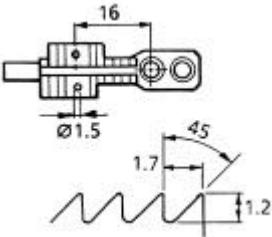
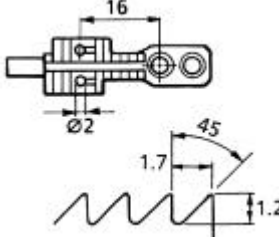
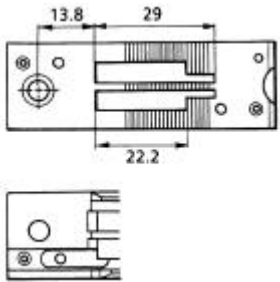
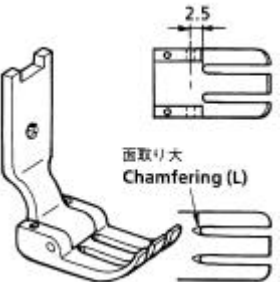
Needle gauge (inch) (mm)	Needle clamp set	Needle clamp assy	Needle plate (-3, -5) For medium & heavy materials	Feed dog		Presser foot assy (-3, -5) For medium & heavy materials
				(-3) For medium materials	(-5) For heavy materials	
3/32 (2.4)	L:S15705-001 R:S15706-001	L:S15707-001 R:S15708-001	159398-001		148697-001	S20223-001
1/8 (3.2)	L:S15711-001 R:S15712-001	L:S15713-001 R:S15714-001	155722-001	148698-001	148699-001	155463-001 S36562-001 ○
5/32 (4.0)	L:S15717-001 R:S15718-001	L:S15719-001 R:S15720-001	155724-001	148700-001	148701-001	155455-001
3/16 (4.8)	L:S15723-001 R:S15724-001	L:S15725-001 R:S15726-001	155851-001	148702-001	148703-001	155457-001 S36564-001 ○
7/32 (5.6)	L:S15729-001 R:S15730-001	L:S15731-001 R:S15732-001	156816-001	S16223-001	S16223-001	S16224-001
1/4 (6.4)	L:S15735-001 R:S15736-001	L:S15737-001 R:S15738-001	155853-001	148704-001	148705-001	155453-001 S36566-001 ○
5/16 (7.9)	L:S15747-001 R:S15748-001	L:S15749-001 R:S15750-001	155855-001	149692-001	149691-001	155459-001
3/8 (9.5)	L:S15753-001 R:S15754-001	L:S15755-001 R:S15756-001	155857-001	149939-001	149938-001	155461-001
1/2 (12.7)	L:S15765-001 R:S15766-001	L:S15767-001 R:S15768-001	149677-001	149676-001	149675-001	S09367-101 ○
5/8 (15.9)	L:S15771-001 R:S15772-001	L:S15773-001 R:S15774-001	149954-001	149949-001	149948-001	159575-101 ○

Needle clamp set	Needle clamp assy	Feed dog	
		(-3) For medium materials	(-5) For heavy materials
			
	Needle plate (-3, -5) For medium & heavy materials	Presser foot assy (-3, -5) For medium & heavy materials	
			

B875 Mark II (For Thread trimmer)

(-6) : For heavy materials

*-6 (for heavy materials) is a specification between -5 (for heavy materials) and -7 (for extra heavy materials).

*The feed dog is different from normal parts.

*The ○ symbol is a presser foot assembly with finger guard.

Needle gauge (inch) (mm)	Needle clamp set	Needle clamp assy	Needle plate	Feed dog	Presser foot assy
3/16 (4.8)	L:S15723-001 R:S15724-001	L:S15725-001 R:S15726-001	155851-001	S07905-001	155457-001 S36564-001 ○
1/4 (6.4)	L:S15735-001 R:S15736-001	L:S15737-001 R:S15738-001	155853-001	158756-001	155453-001 S36566-001 ○

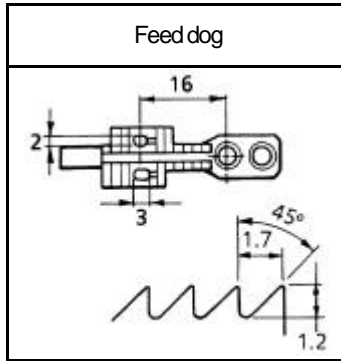



B8750 Mark II (With ply sensor and thread trimmer)

For normal

*The thread trimming fixed knife (part No. S07527-001) and the installation screw (part No. 148539-101) are not provided with the needle plate, so they must be ordered separately if required.

*The ○ symbol is a presser foot assembly with finger guard.

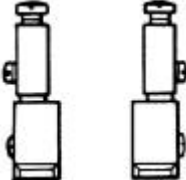
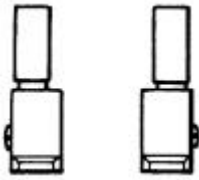
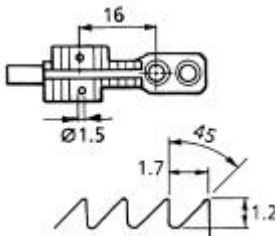
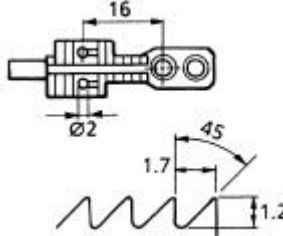
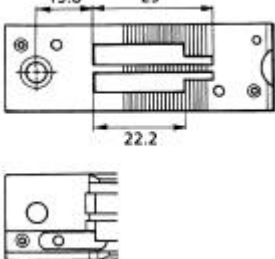
Needle gauge (inch) (mm)	Needle clamp set	Needle clamp assy	Needle plate (-3,-5) For medium & heavy materials	Feed dog		Presser foot assy (-3,-5) For medium & heavy materials
				(-3) For medium materials	(-5) For heavy materials	
5/32 (4.0)	L:S15717-001 R:S15718-001	L:S15719-001 R:S15720-001	S13512-101	148700-001	148701-001	155455-001
3/16 (4.8)	L:S15723-001 R:S15724-001	L:S15725-001 R:S15726-001	S13514-101	148702-001	148703-001	155457-001 S36564-001 ○
1/4 (6.4)	L:S15735-001 R:S15736-001	L:S15737-001 R:S15738-001	S13510-101	148704-001	148705-001	155453-001 S36566-001 ○
5/16 (7.9)	L:S15747-001 R:S15748-001	L:S15749-001 R:S15750-001	S13516-101	149692-001	149691-001	155459-001
3/8 (9.5)	L:S15753-001 R:S15754-001	L:S15755-001 R:S15756-001	S13518-101	149939-001	149938-001	155461-001

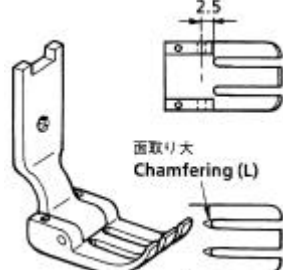
Needle clamp set	Needle clamp assy	Feed dog	
		(-3) For medium materials	(-5) For heavy materials
			
	Needle plate (-3,-5) For medium & heavy materials	Presser foot assy (-3,-5) For medium & heavy materials	
			

B8750 Mark II (With ply sensor and thread trimmer)

(-6) : For heavy materials

*-6 (for heavy materials) is a specification between -5 (for heavy materials) and -7 (for extra heavy materials).

*The feed dog is different from normal parts.

*The ○ symbol is a presser foot assembly with finger guard.

Needle gauge (inch) (mm)	Needle clamp set	Needle clamp assy	Needle plate	Feed dog	Presser foot assy
3/16 (4.8)	L:S15723-001 R:S15724-001	L:S15725-001 R:S15726-001	S13514-101	S07905-001	155457-001 S36564-001 ○
1/4 (6.4)	L:S15735-001 R:S15736-001	L:S15737-001 R:S15738-001	S13510-101	158756-001	155453-001 S36566-001 ○

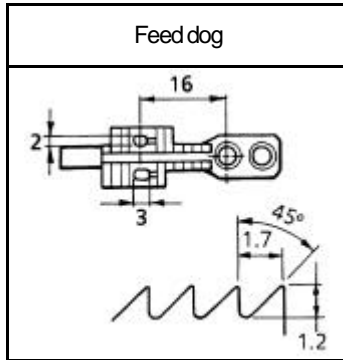

* Maximum stitch width and gauge part sizes that require special sewing machine processing.

Model name	Gauge part sizes which require special sewing machine processing	Maximum stitch width	
		(inch)	(mm)
LT2-B841	Over 1-1/2" (38.1mm)		(77)
LT2-B842 (Standard)	Over 1-1/2" (38.1mm)		(77)
LT2-B842 (Thread trimmer)	Over 1-1/2" (38.1mm)	2	(50.8)
LT2-B845 (Standard)	5/8	(15.9)
LT2-B845 (Thread trimmer)		5/8	(15.9)
LT2-B847 (Standard)	Over 1-1/2" (38.1mm)		(77)
LT2-B847 (Thread trimmer)	Over 1-1/2" (38.1mm)		(77)
LT2-B848 (Standard)	5/8	(15.9)
LT2-B848 (Thread trimmer)		5/8	(15.9)
LT2-B872 (Standard)		(68)
LT2-B872 (Thread trimmer)	Over 1-1/2" (38.1mm)	1-3/4	(44.5)
LT2-B875 (Standard)	5/8	(15.9)
LT2-B875 (Thread trimmer)	5/8	(15.9)