

**SERVICE MANUAL**  
**FOR**  
**BAS-410**  
**SINGLE HEAD EMBROIDERY MACHINE**

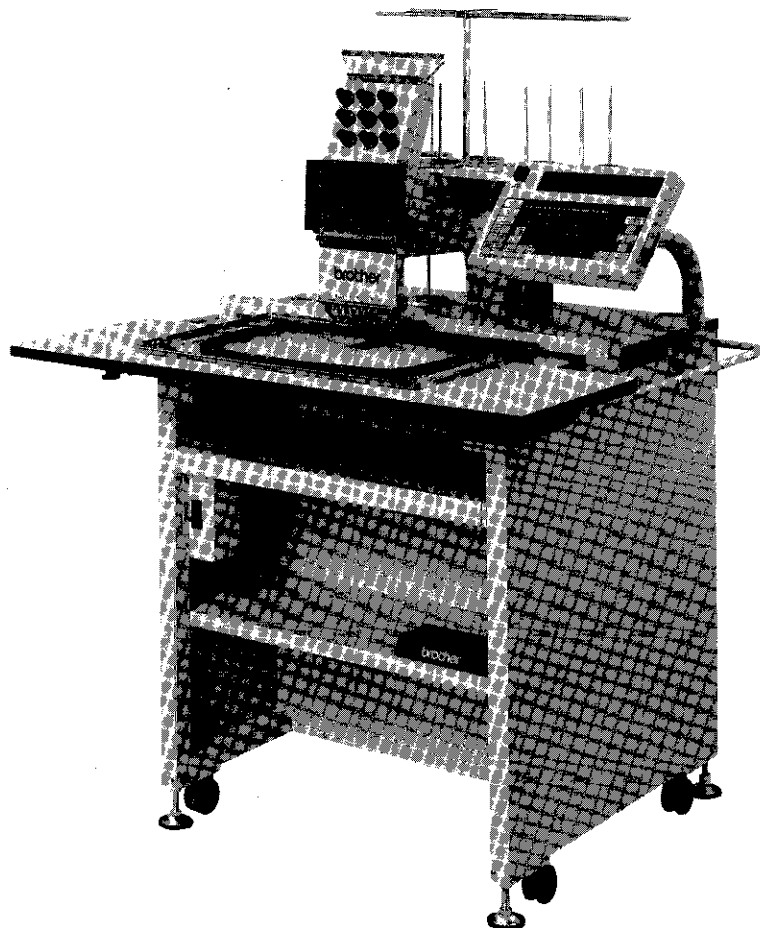

# CONTENTS

|  |      |
|--|------|
| <b>NAMES OF MAIN PARTS</b> .....                   | -1-  |
| <b>MECHANICAL DESCRIPTIONS</b> .....               | -2-  |
| ① Upper shaft and needle bar mechanism .....       | -2-  |
| ② Lower shaft and rotary hook mechanism .....      | -3-  |
| ③ Thread trimmer mechanism .....                   | -4-  |
| ④ Thread wiper mechanism .....                     | -5-  |
| ⑤ Needle bar flip-up mechanism .....               | -6-  |
| ⑥ Picker mechanism .....                           | -7-  |
| ⑦ Drive, (X) feed mechanism .....                  | -8-  |
| ⑧ Drive, (Y) feed mechanism .....                  | -9-  |
| <b>STANDARD ADJUSTMENTS</b> .....                  | -10- |
| ① Adjusting needle bar height .....                | -10- |
| ② Adjusting timing of needle and rotary hook ..... | -11- |
| ③ Adjusting cloth holder (presser) height .....    | -11- |
| ④ Adjusting knife and fixed knife .....            | -12- |
| ⑤ Adjusting picker .....                           | -13- |
| ⑥ Adjusting the thread wiper .....                 | -14- |
| ⑦ Adjusting wire tension .....                     | -15- |
| 1. X-feed wire .....                               | -15- |
| 2. Y-feed wire .....                               | -16- |
| ⑧ Adjusting thread breakage detect stud .....      | -17- |
| ⑨ Adjusting bobbin winder .....                    | -18- |
| ⑩ BAS-410 test mode .....                          | -19- |
| ⑪ Adjusting synchronizer .....                     | -21- |
| <b>LUBRICATION</b> .....                           | -23- |
| ① Machine head .....                               | -23- |
| ② Feed-guide mechanism .....                       | -24- |
| <b>REPLACING AND ADJUSTING PARTS</b> .....         | -25- |
| ① Removing and adjusting machine head (1) .....    | -25- |
| ② Removing and adjusting machine head (2) .....    | -26- |
| ③ Removing needle bar case .....                   | -27- |
| ④ Replacing up and down motion parts .....         | -28- |
| ⑤ Replacing jump solenoid .....                    | -29- |
| ⑥ Attaching X wire .....                           | -30- |
| ⑦ Attaching Y wire .....                           | -31- |

|  |      |
|--|------|
| <b>EXPLANATION OF CIRCUIT BOARDS</b> ..... | -32- |
| ① Positions of circuit boards .....        | -32- |
| ② Replacing circuit boards .....           | -33- |
| ③ Explanation of fuses .....               | -40- |
| ④ Explanation of P-ROM .....               | -41- |
| ⑤ Explanation of DIP switches .....        | -42- |
| <b>OPTIONAL PARTS</b> .....                | -45- |
| ① Small lamp for machine .....             | -45- |

# NAMES OF MAIN PARTS

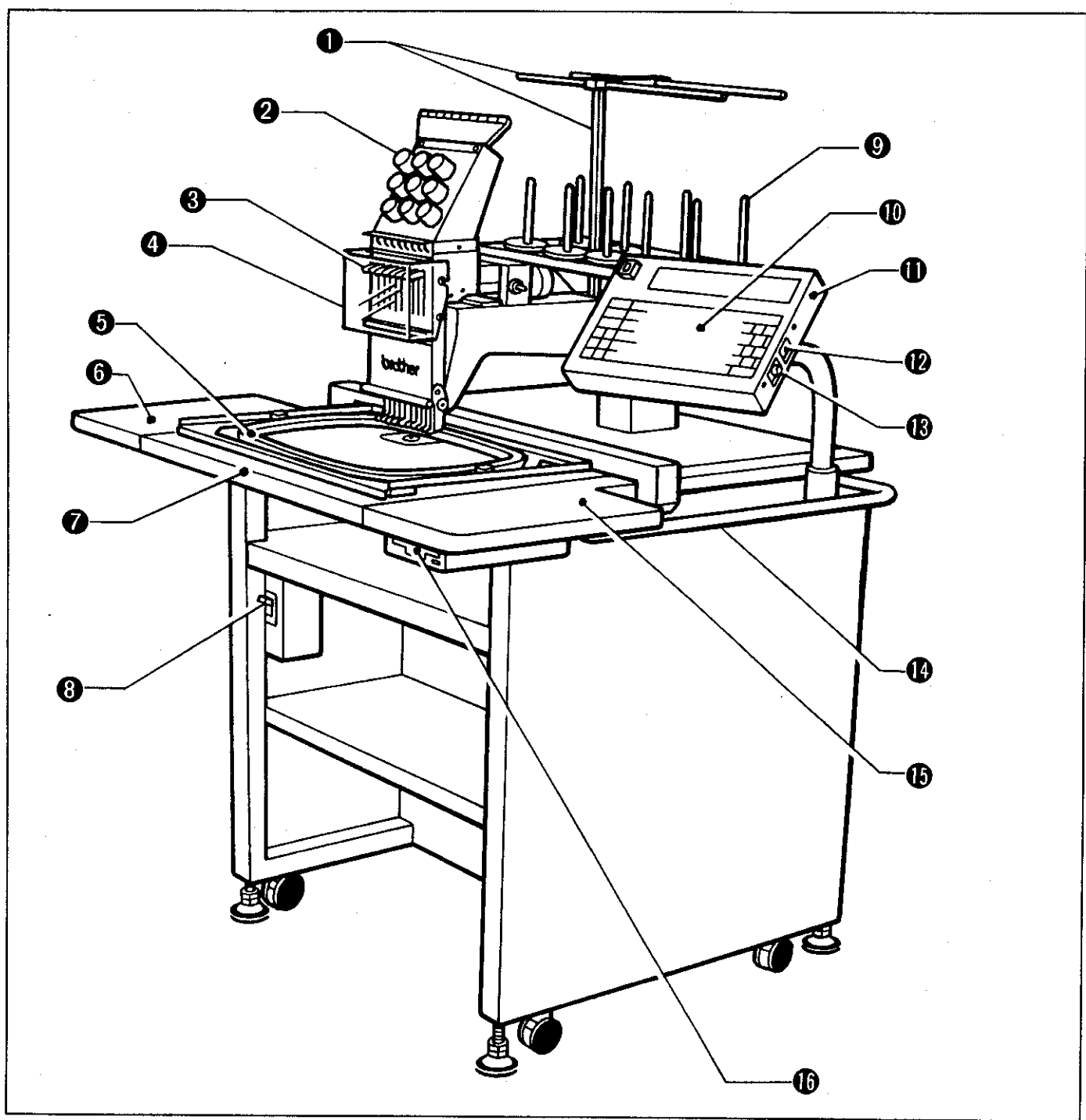

- |                        |                       |                                   |
|------------------------|-----------------------|-----------------------------------|
| ① thread guide bar     | ② thread tension dial | ③ thread take-up                  |
| ④ thread take-up cover | ⑤ embroidery hoop     | ④ table (L)                       |
| ⑦ table (C)            | ⑥ power switch        | ⑤ spool shaft (B)                 |
| ⑩ operation panel      | ⑦ keyboard (assembly) | ⑥ contrast dial of liquid crystal |
| ⑪ speed dial           | ⑧ guard bar           | ⑦ table (R)                       |
| ⑫ floppy disc drive    |                       |                                   |

# MECHANICAL DESCRIPTIONS

## 1 Upper shaft mechanism

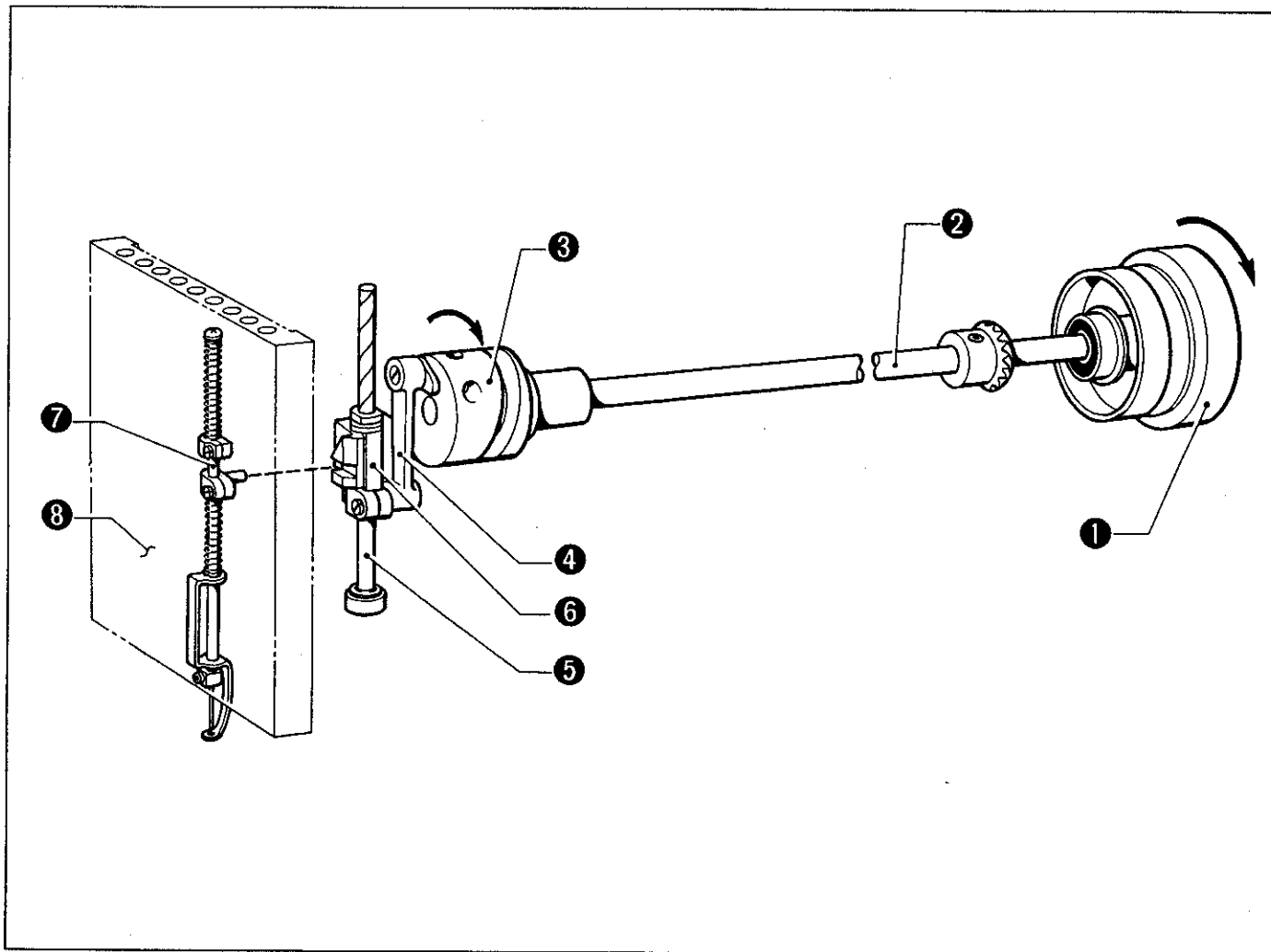

- 1) When the pulley ① rotates in the direction of the arrow, it transmits the rotation to the upper shaft ②. The upper shaft ② then rotates the thread take-up driving cam ③.
- 2) The thread take-up driving cam ③ transmits the motion to the connecting rod ④.
- 3) The up and down motion parts ⑥, attached to the main needle bar ⑤, move the needle bar ⑦ up and down.
- 4) The needle bar ⑦ is guided by the needle bar case ⑥.

## 2 Lower shaft and rotary hook mechanism

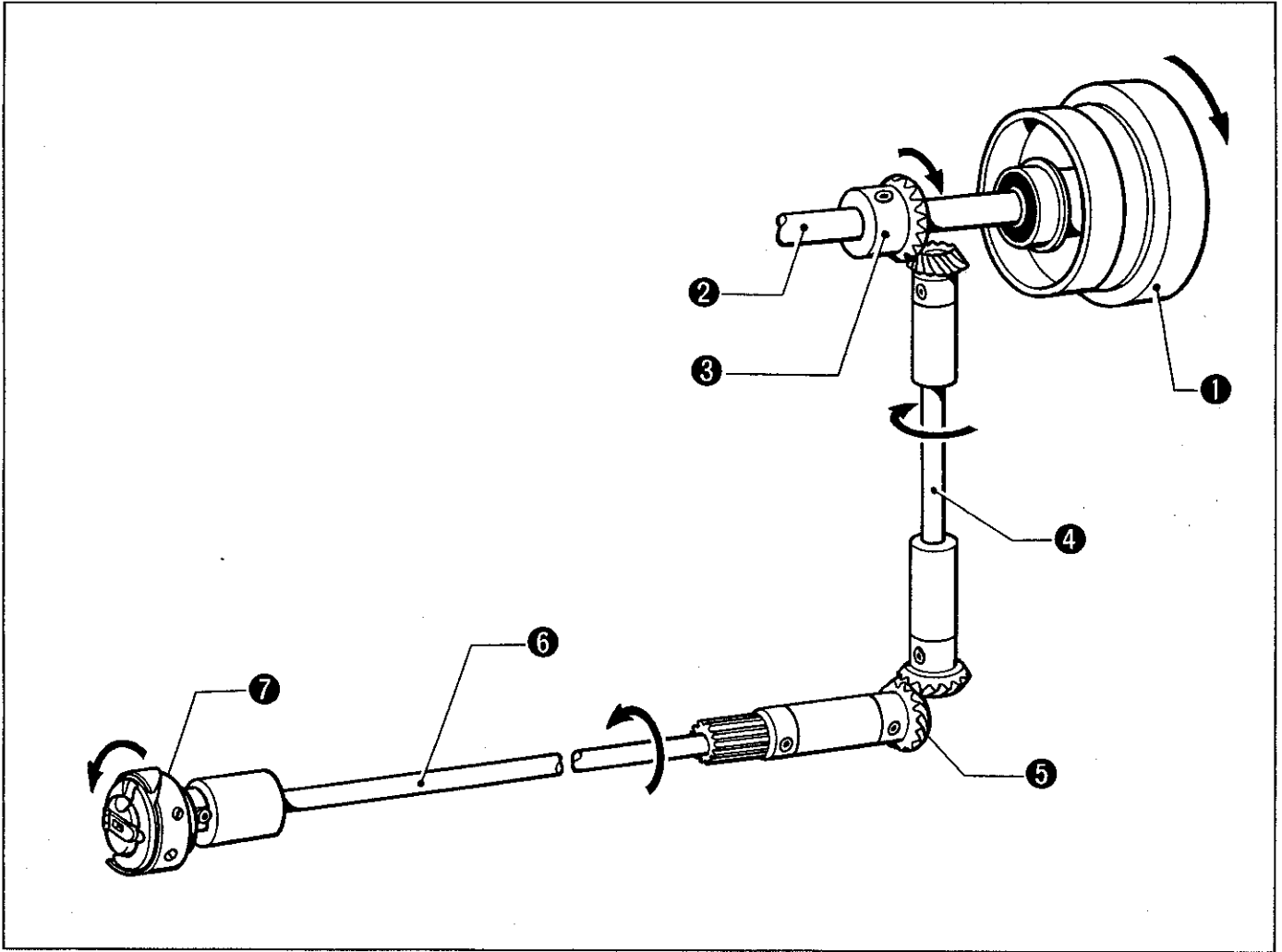

- 1) When the pulley ① rotates in the direction of the arrow, it transmits the rotation to the upper shaft ②. The upper shaft ② then rotates the upper shaft gear (A) ③.
- 2) The upper shaft gear (A) ③ transmits the movement to the lower shaft gear ⑤ via the vertical shaft ④.
- 3) The lower shaft gear ⑤ transmits the rotation to the attached lower shaft ⑥. Then the rotary hook ⑦, attached to the lower shaft ⑥, rotates in the direction of the arrow.

NOTE: In BAS - 410, the rotary hook makes two revolutions for each revolution made by the pulley.

### ③ Thread trimmer mechanism

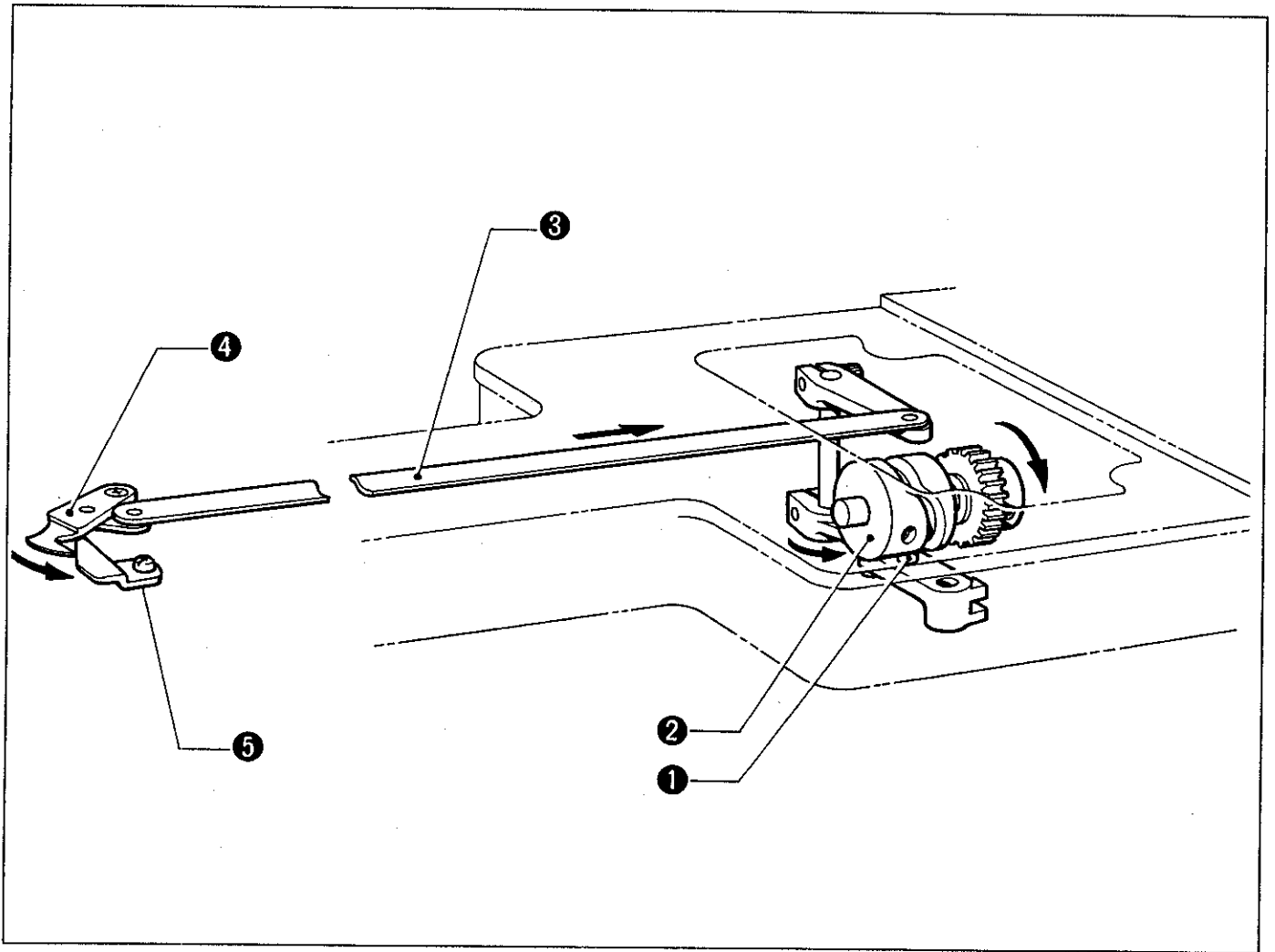

After the final stitch, roller shaft (A) ① moves into the groove of the cam ②, and connecting plate (B) ③ moves. Then the knife ④ engages with the fixed knife ⑤, trimming the thread.

#### 4 Thread wiper mechanism

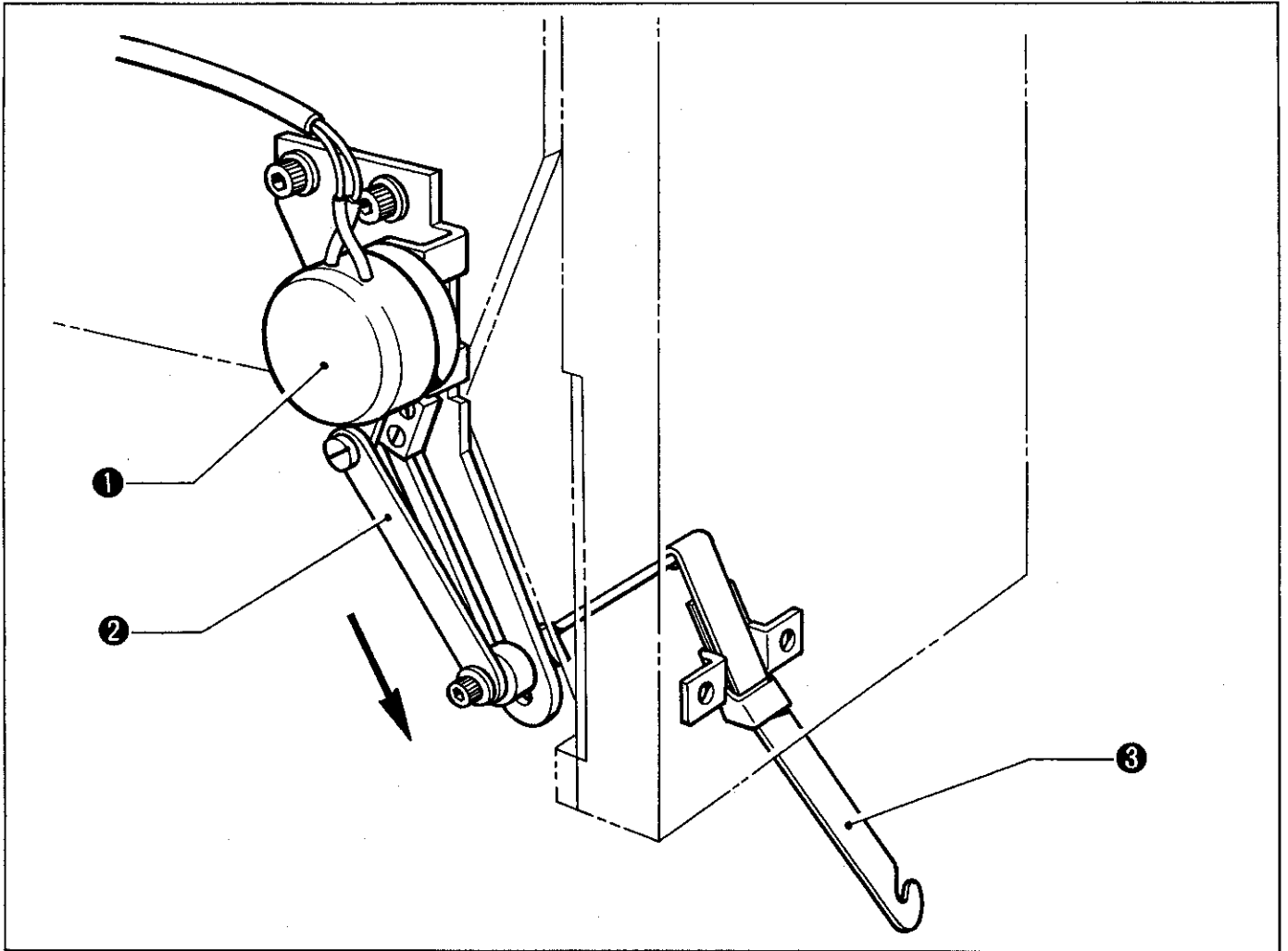

After sewing is completed, the thread guide solenoid ① moves the plate ② in the direction of the arrow, and the upper thread guide hook ③ attached to the plate ② brings the trimmed thread to the thread presser. The thread presser secures the trimmed thread.

## 5 Needle bar flip-up mechanism

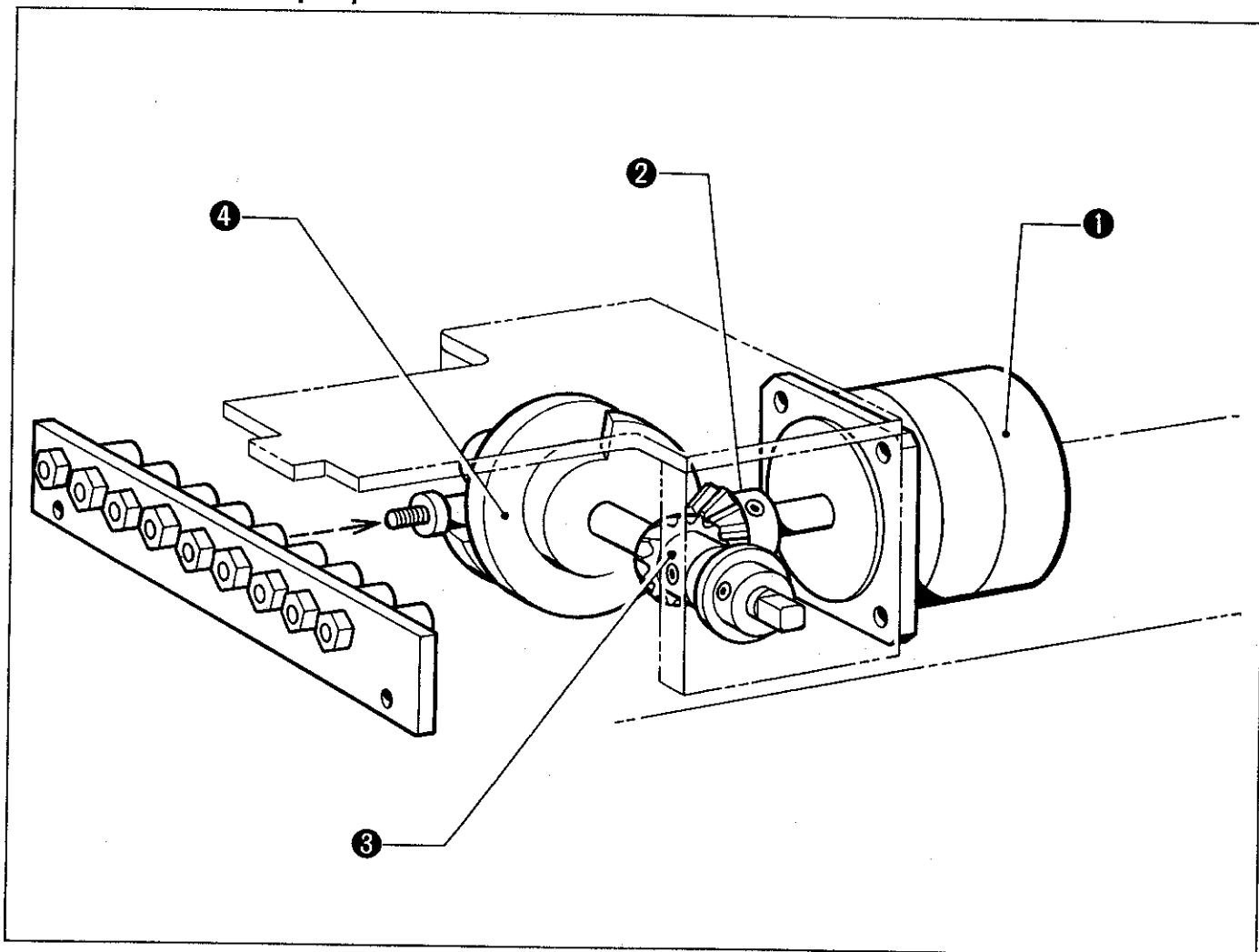

After receiving the set needle bar flip-up signal, cam gears (A) ② and (B) ③ attached to the pulse motor ① are activated. The needle bar flip-up is performed by the change cam ④.

## 6 Picker mechanism

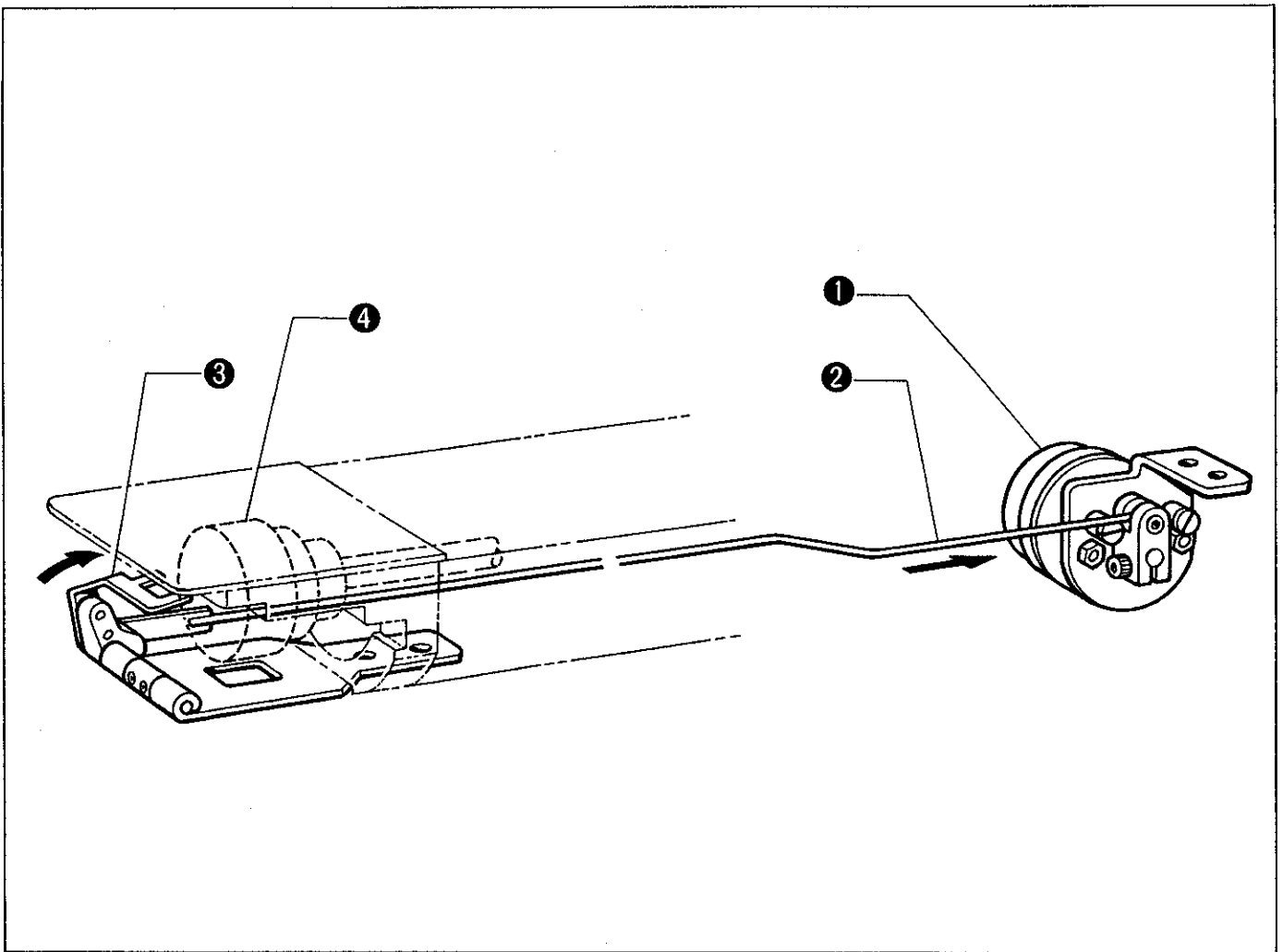

The picker solenoid ① functions at the beginning of sewing and after thread trimming. The picker ③ attached to connecting plate (A) ② moves in the direction of the bobbin case ④, then pulls the upper thread under the material.

During thread trimming, the picker ③ operates to keep the needle thread length constant.

## 7 Drive, (X) feed mechanism

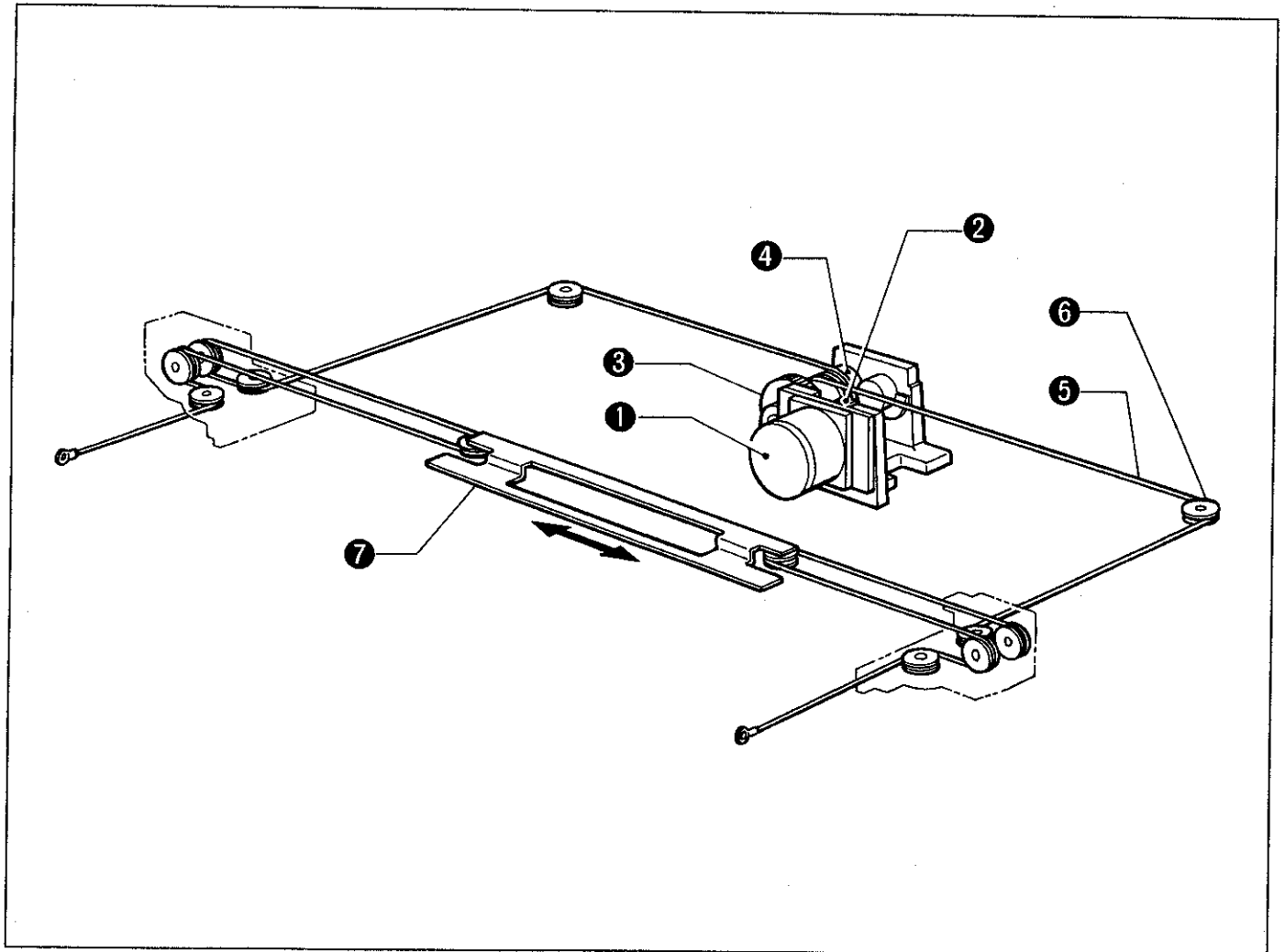

- 1) Pinion gear (B) ② attached to the X-pulse motor ① rotates, then transmits the rotation to idle gear (A) ③.
- 2) When idle gear (A) ③ rotates, the (X) wire ⑤ reeled in the wire drum (X) ④ moves the carriage ⑦ in the direction of the X-axis (left ↔ right) via the pulley ⑥.

## 8 Drive, (Y) feed mechanism

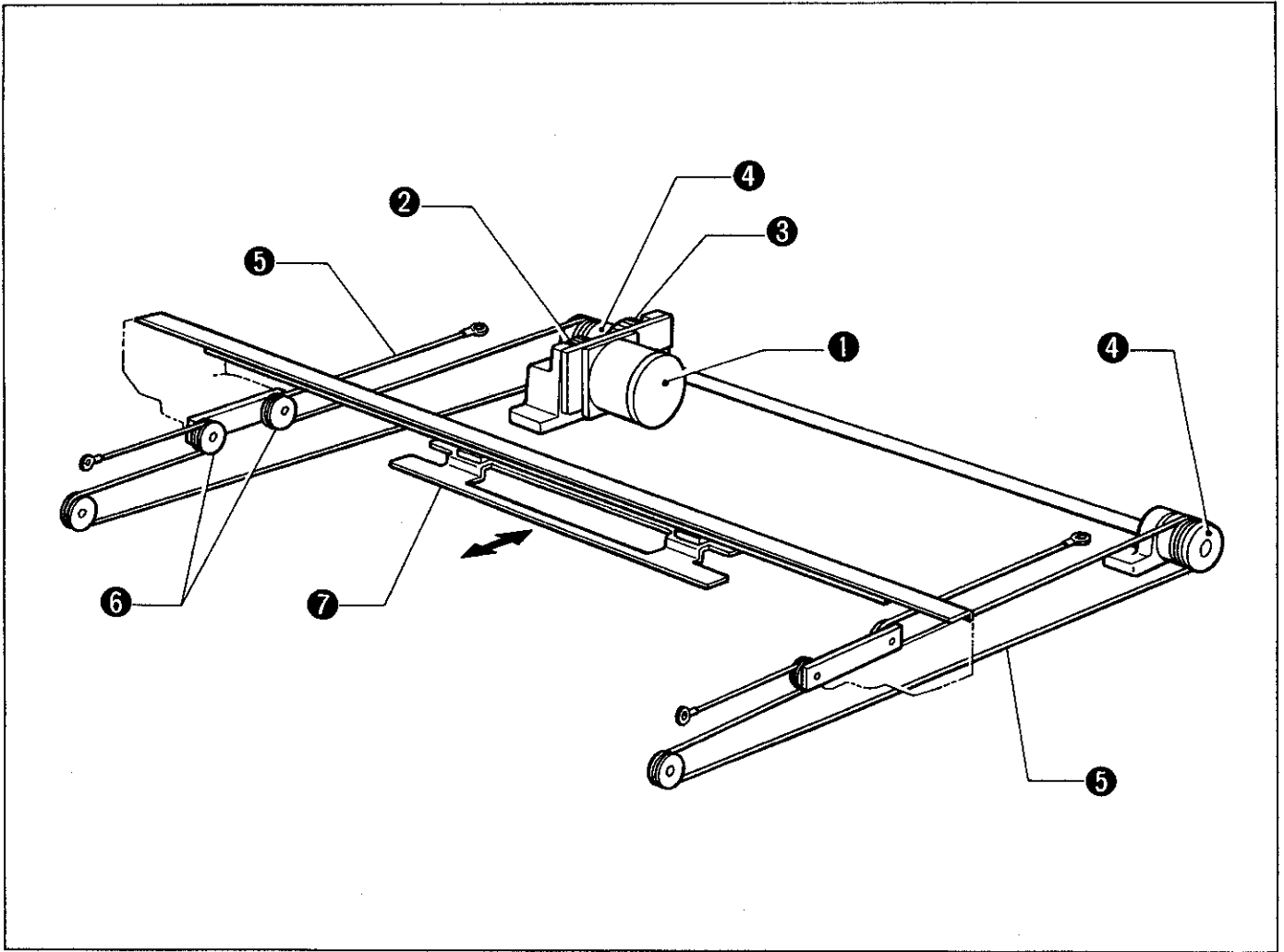

- 1) Pinion gear (B) ② of the Y-pulse motor ① rotates, then transmits the rotation to idle gear (A) ③.
- 2) When idle gear (A) ③ rotates, the (Y) wires ⑤ (left) and (right) reeled in the wire drums (Y) ④ on the right and the left move the carriage ⑦ in the direction of the Y-axis (backwards ↔ forwards) via the pulley ⑥.

# STANDARD ADJUSTMENTS

## 1 Adjusting needle bar height

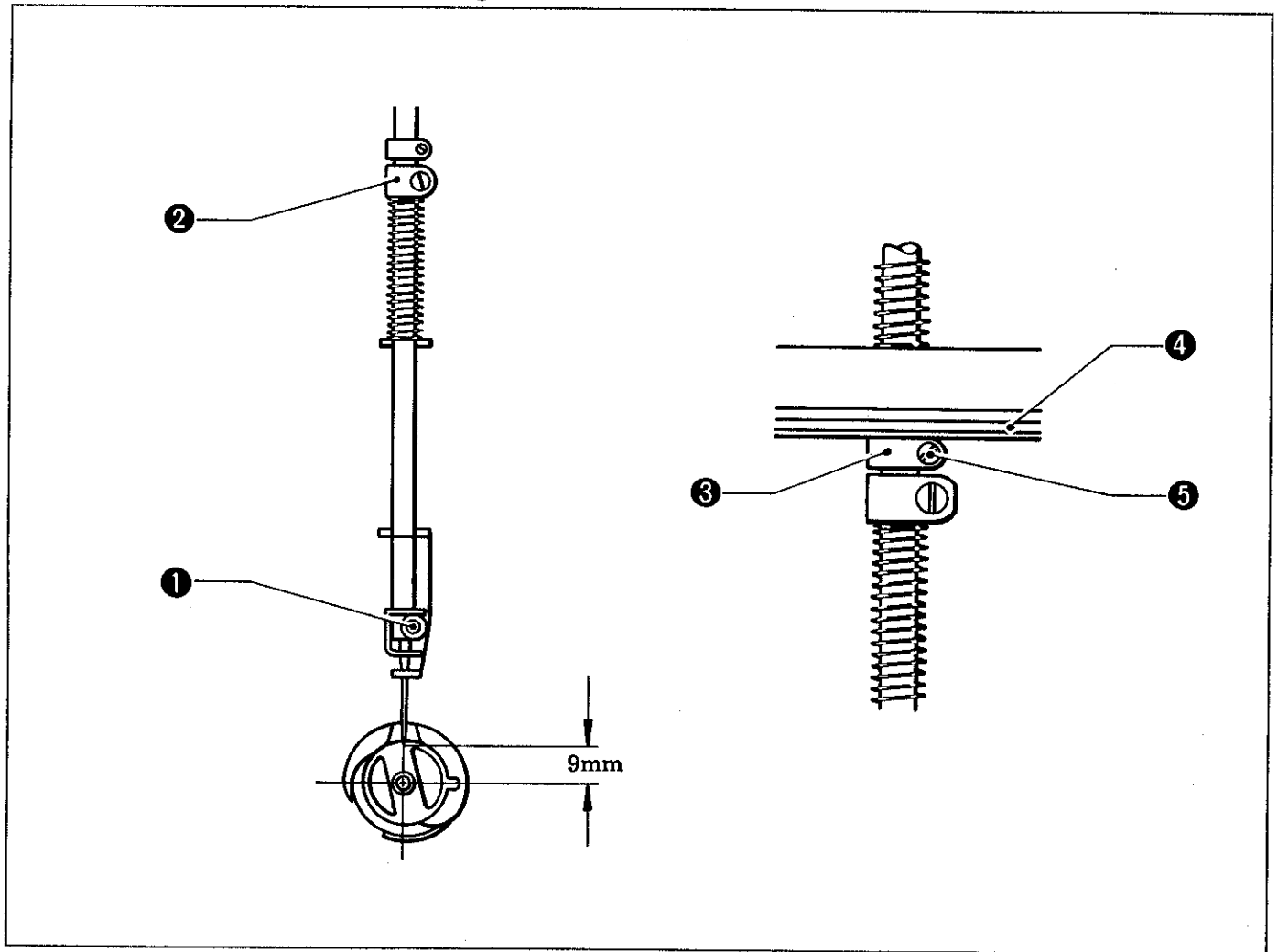

- 1) Lower the needle bar to its lowest position. When the needle tip is raised 9 mm above the center of the rotary hook shaft, tighten the screw of the needle bar clamp ② so that the screw ① leans to the right 25° - 30°.
- 2) Lower the needle bar to its lowest position. Lightly press the stopper ③ to the cushion rubber ④ side. Then tighten the screw ⑤ so that it is positioned in the front.

NOTE: Make sure that the stopper does not strike the needle bar guide rail.

## 2 Adjusting timing of needle and rotary hook

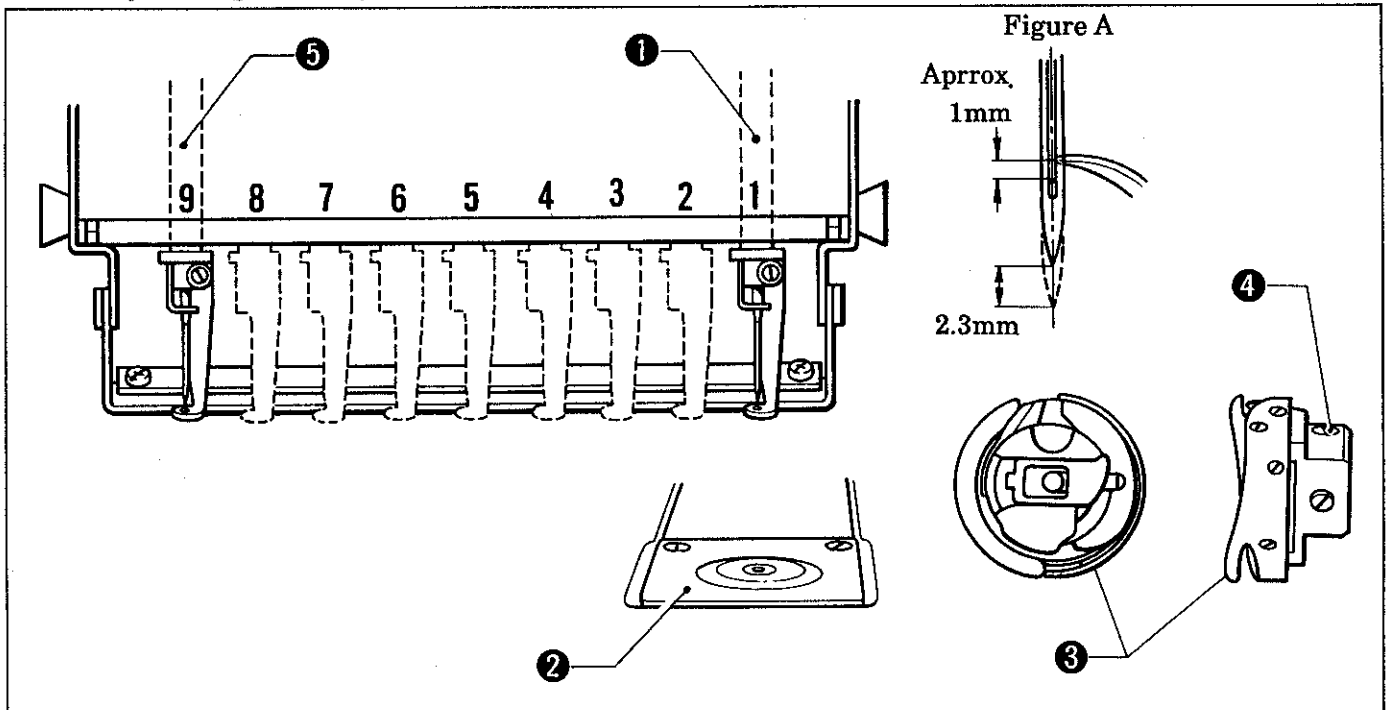

- 1) Select the first needle bar ①.
- 2) Remove two screws and the needle plate ②.
- 3) When the needle bar is raised 2.3 mm (201°) above its lowest position (180°), loosen the screw ④ of the rotary hook ③, and adjust so that the needle meets the rotary hook point.  
At this time, the needle bar height should be about 1 mm. (Figure A)
- 4) Select the ninth needle bar ⑤. If the gap between the needle bar and rotary hook is 0.01 - 0.2 mm, tighten the three screws of the rotary hook.

## 3 Adjusting cloth holder (presser) height

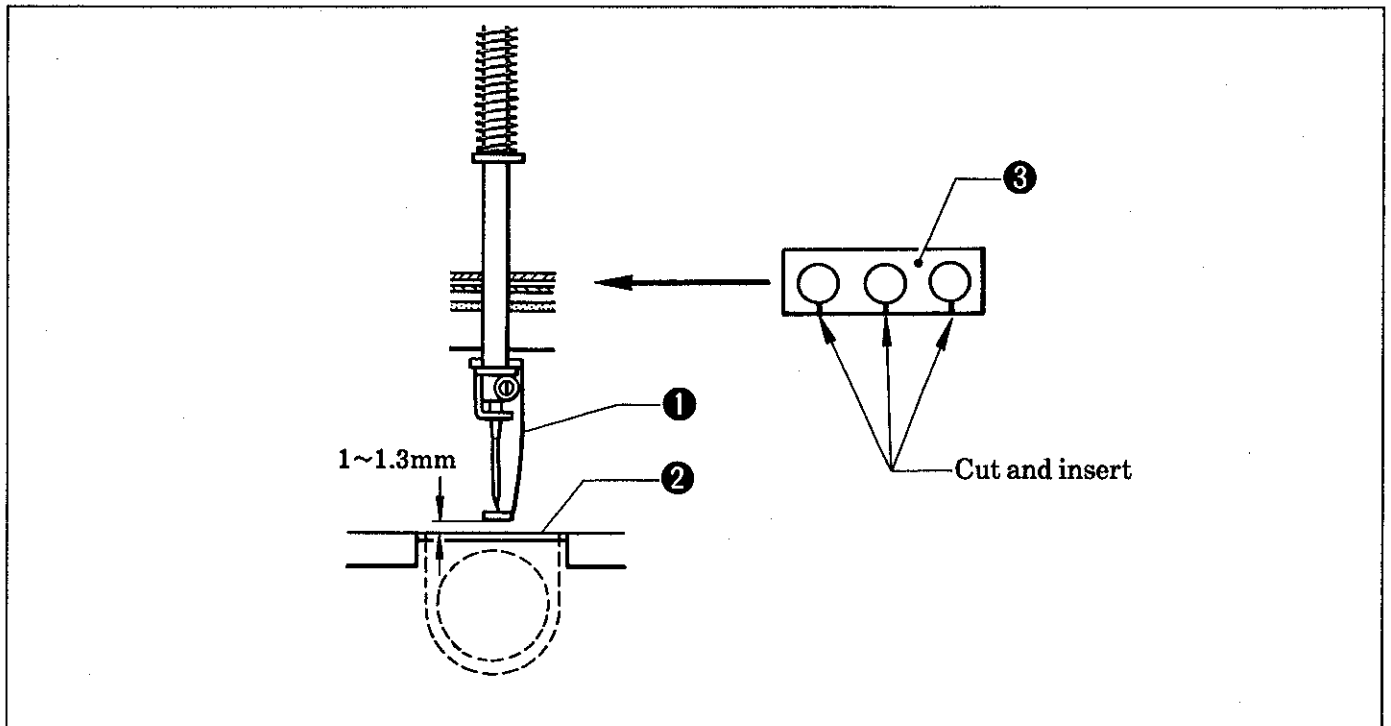

Adjust the cloth presser (holder) ① height with the space rubber ③. The cloth presser (holder) ① height should be raised 1 - 1.3 mm from the needle plate ② at the needle bar's lowest position. (A sheet of the space rubber is 0.5 mm thick.)

## 4 Adjusting knife and fixed knife

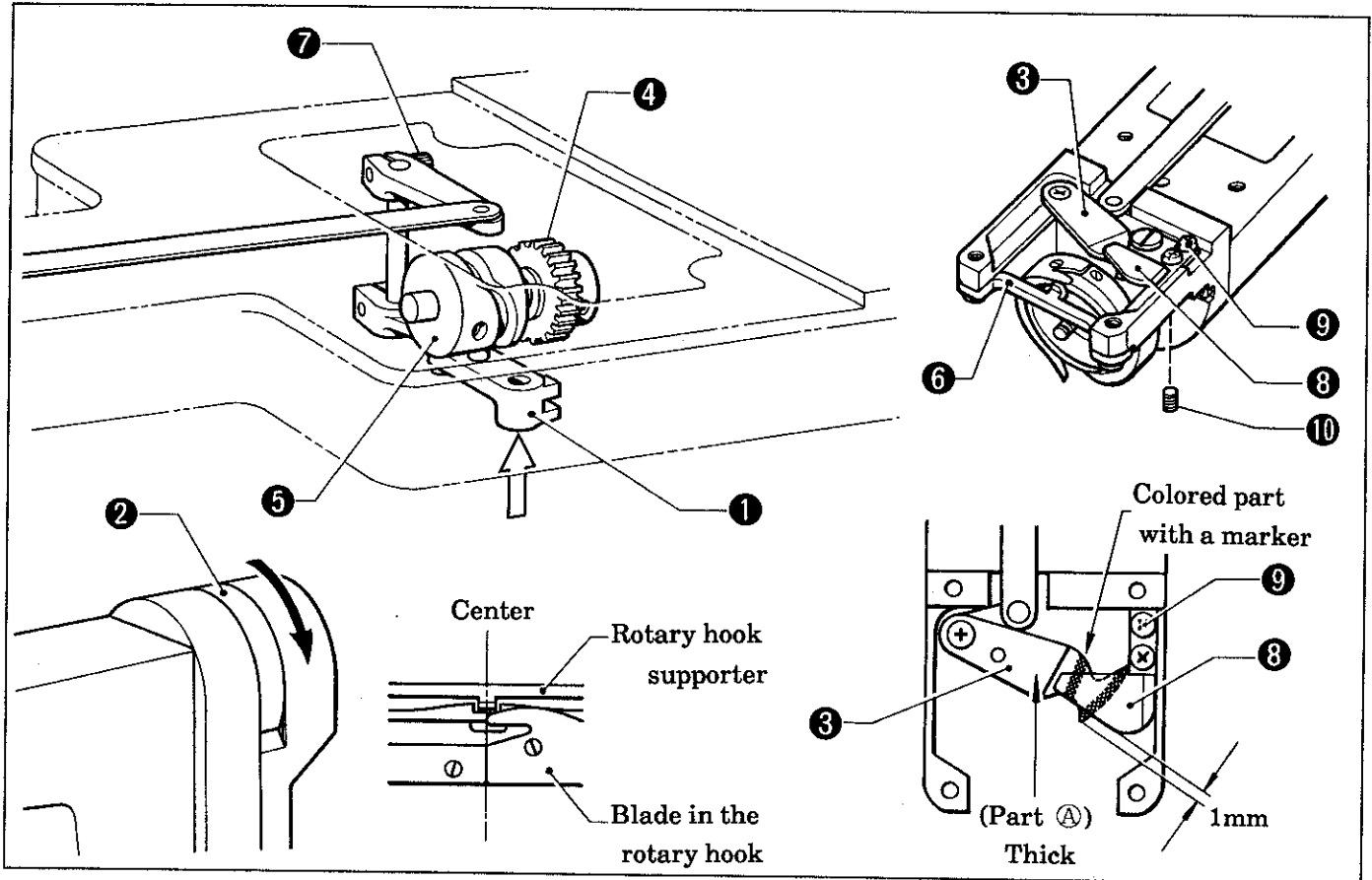

### 1. Attaching fixed knife

- 1) Attach the fixed knife so that the attached part parallels the rotary hook base. The movable knife broadens at part (A). Make sure the fixed knife doesn't contact it at this part.

### 2. Knife timing

- 1) While pushing the cam lever ① up with a finger, rotate the pulley ② in the direction of the arrow. When the knife ③ begins to move, the pulley will become harder to turn. At this time, tighten the screw of the 24 J gear ④, fix the cam ⑤ by hand so it does not rotate, and turn the pulley. The rotary hook blade should be in the center of the rotary hook supporter ⑥.
- 2) Tighten the screw of the 24 J gear ④ so there is no backlash of the cam in the direction of the lower shaft. While pushing the cam lever ① up with a finger, rotate the pulley ② again. When the knife ③ begins to move, the blade in the rotary hook should be the center of the rotary hook supporter ⑥.

### 3. Knife position

Loosen the screw ⑦ and adjust the knife ③ position so that its end projects 1 mm beyond the fixed knife's tip. After thread trimming, the knife should be in this position.

### 4. Knife and fixed knife

- 1) With a marker, color the back of the knife ③ and engage it with the fixed knife ③ manually. Check that the colored portion is shaved equally. This shows proper knife engagement.
- 2) If the engagement is wrong, loosen the screw ⑨ of the fixed knife ③ and adjust the inclination with the lower set screw ⑩.

NOTE: The inclination of the fixed knife ③ should be adjusted with the two top screws ⑨ and the bottom set screw ⑩.

NOTE: This is fine adjustment. Adjust carefully.

## 5 Adjusting picker

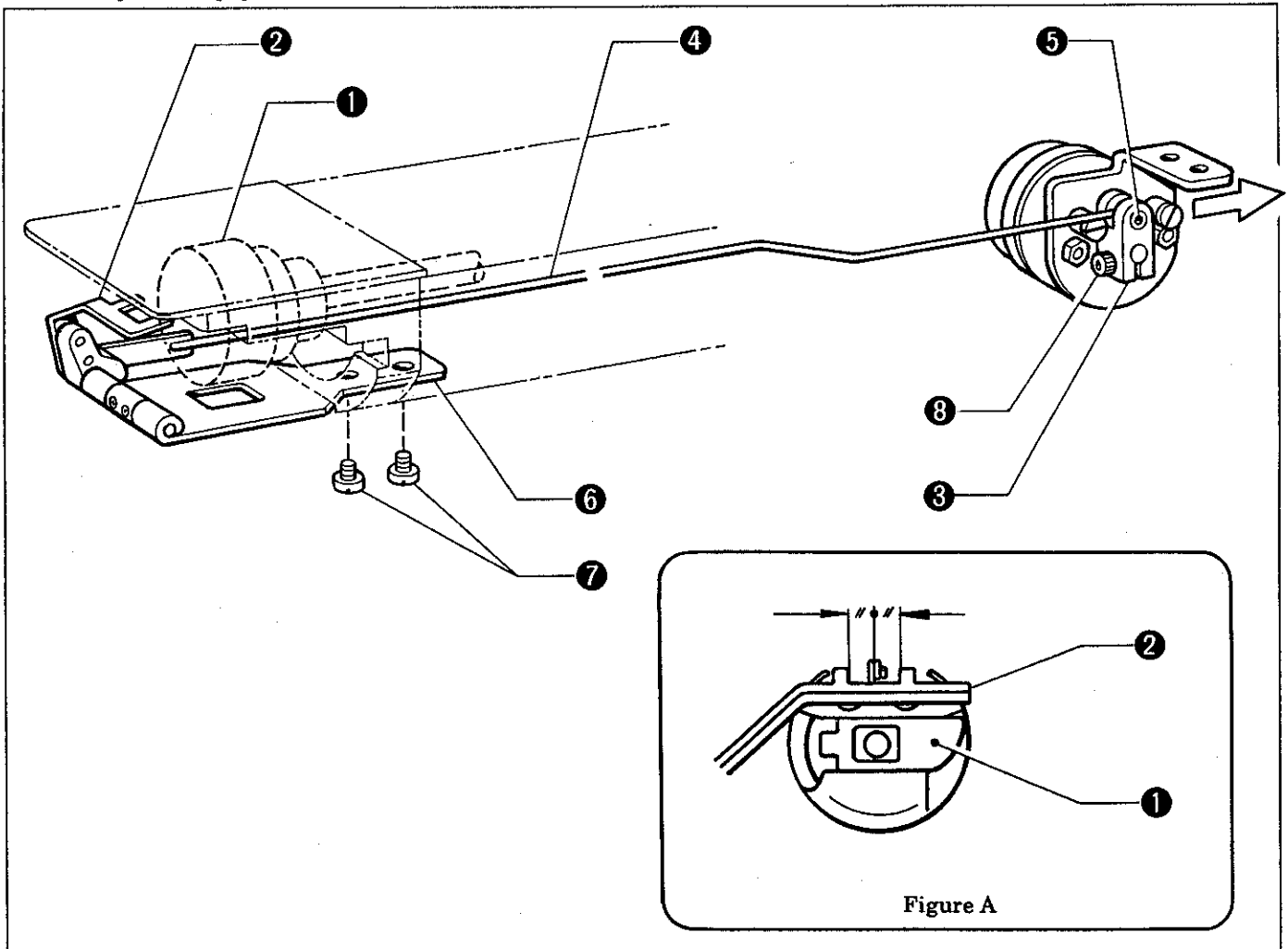

- 1) Insert the bobbin case ① containing the bobbin into the rotary hook and set the picker ② position.
- 2) Leave the solenoid arm ③ pushed to the needle bar side, then tighten connecting plate (A) ④ with the screw ⑤.
- 3) Adjust the picker ② so that there is no looseness and so that it functions lightly. Then tighten the picker bracket ⑥ with the screw ⑦.
- 4) Adjust the gap between the point of the picker and the bobbin to 1 - 1.5 mm. Leave the solenoid arm ③ pushed to the pulley side (the solenoid operation position), then tighten the screw ⑤.
- 5) Adjust the picker position so that it is bisected by the bobbin case spring (see figure A).

## 6 Adjusting the thread wiper

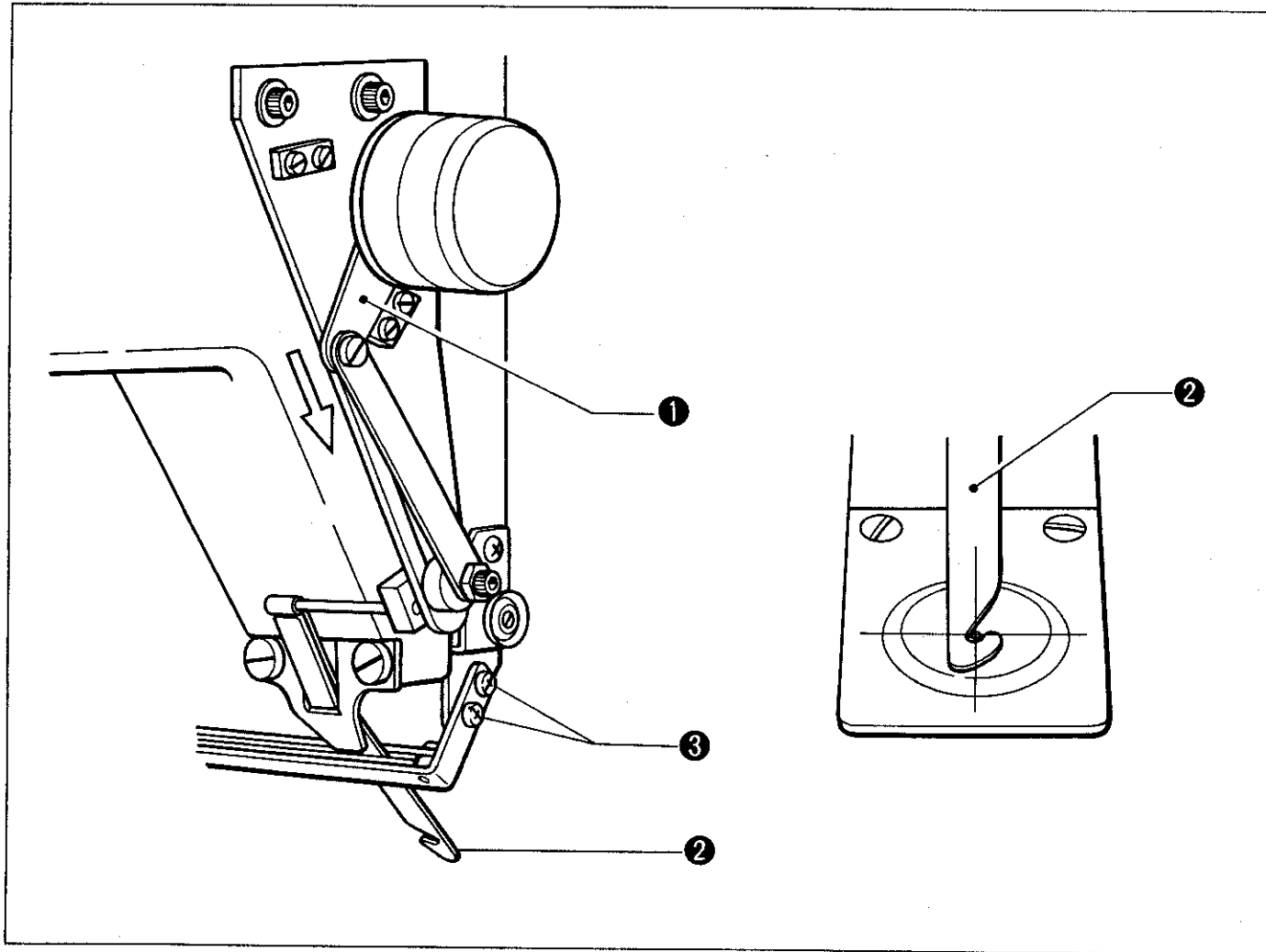

- 1) With a finger, move the solenoid arm ① in the direction of the arrow. Loosen the two screws ③ then adjust the upper thread guide hook ② so that it moves slightly.
- 2) Adjust the upper thread guide hook ② so that its cut part is located at the center of the needle hole.

## 7 Adjusting wire tension

### 1. X-feed wire

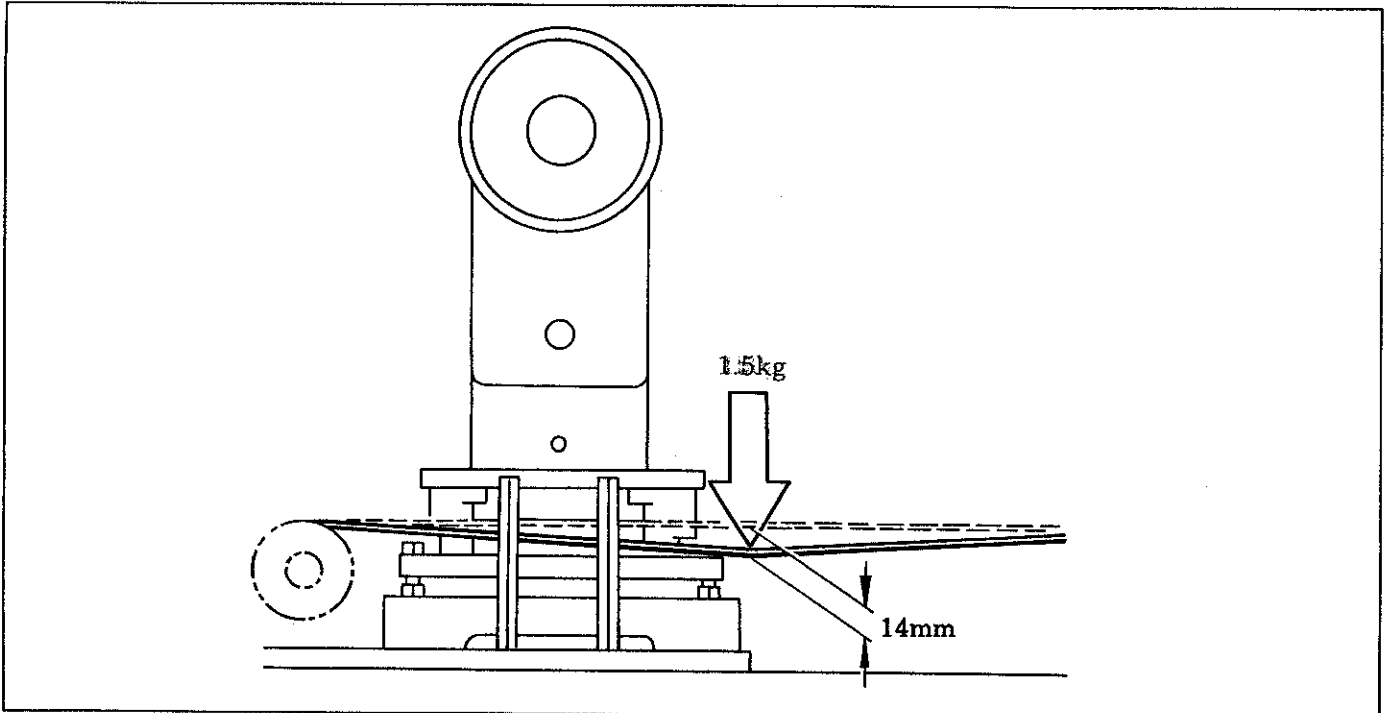

Using a 1.5kg torque wrench or a similar tool, push at the location marked by the arrow and adjust so there is a deflection of approximately 14mm.

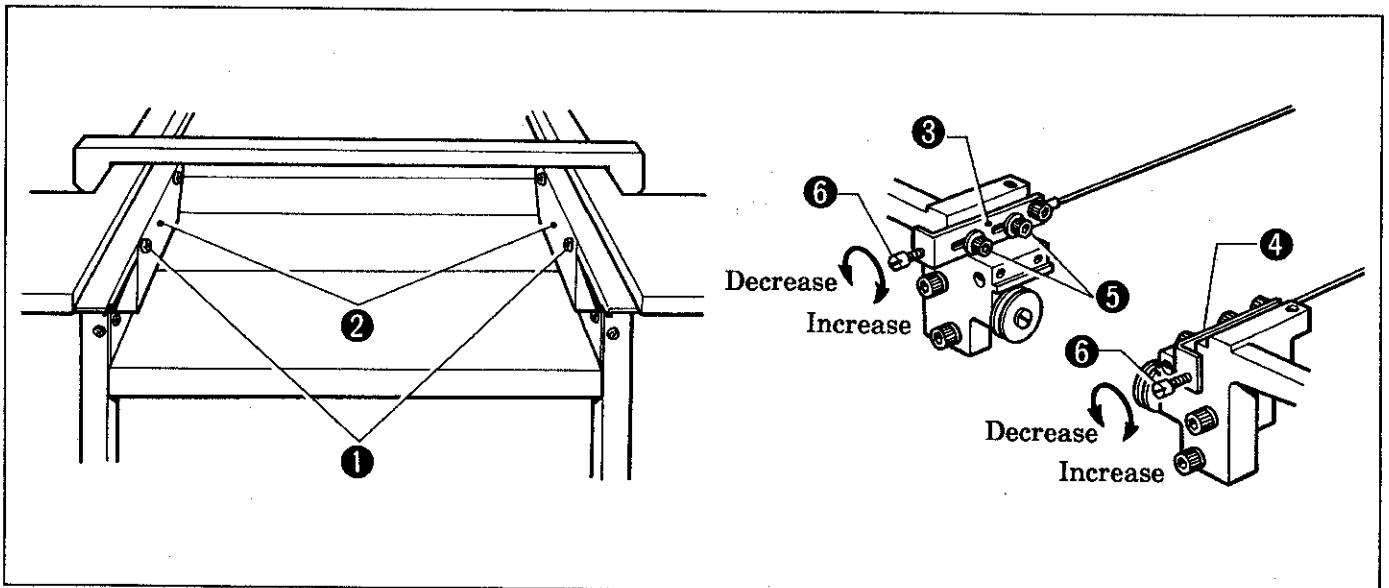

#### How to adjust

- 1) Remove the 7 screws ① and the two covers (LR,LL) ②.
- 2) Loosen the two screws ⑤ of both hook (LX) ③ and hook (RX) ④.
- 3) There are 2 stoppers (U) ⑥ on the right and the left sides. Turning them clockwise will increase the tension and turning them counterclockwise will decrease the tension.
- 4) When the tension is proper, tighten screw ⑤.
- 5) After tightening screw ⑤, firmly retighten stoppers (U) ⑥ so there is no looseness.

## 2. Y-feed wire

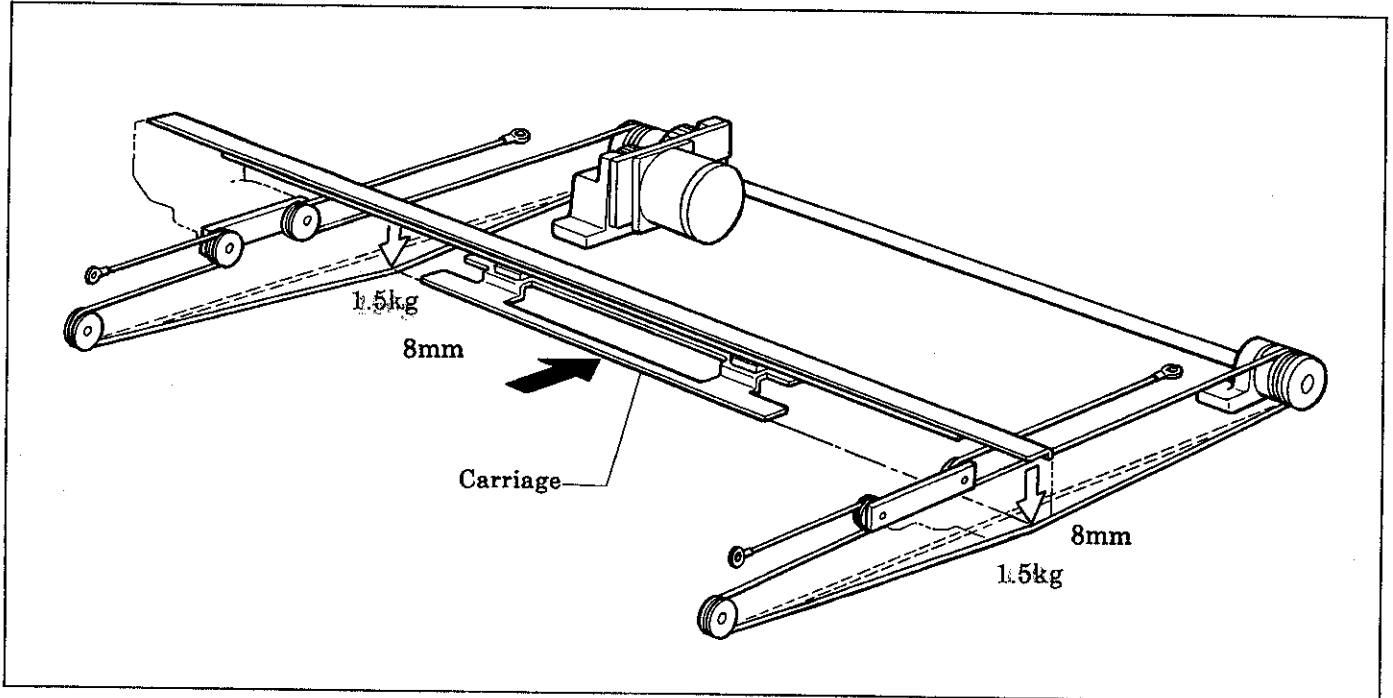

At points on the right and left wires where a line extended from the carriage intersects (see the arrow-marked points in diagram), adjust the deflection to approximately 8mm, using a 1.5kg torque wrench or a similar tool.

### How to adjust

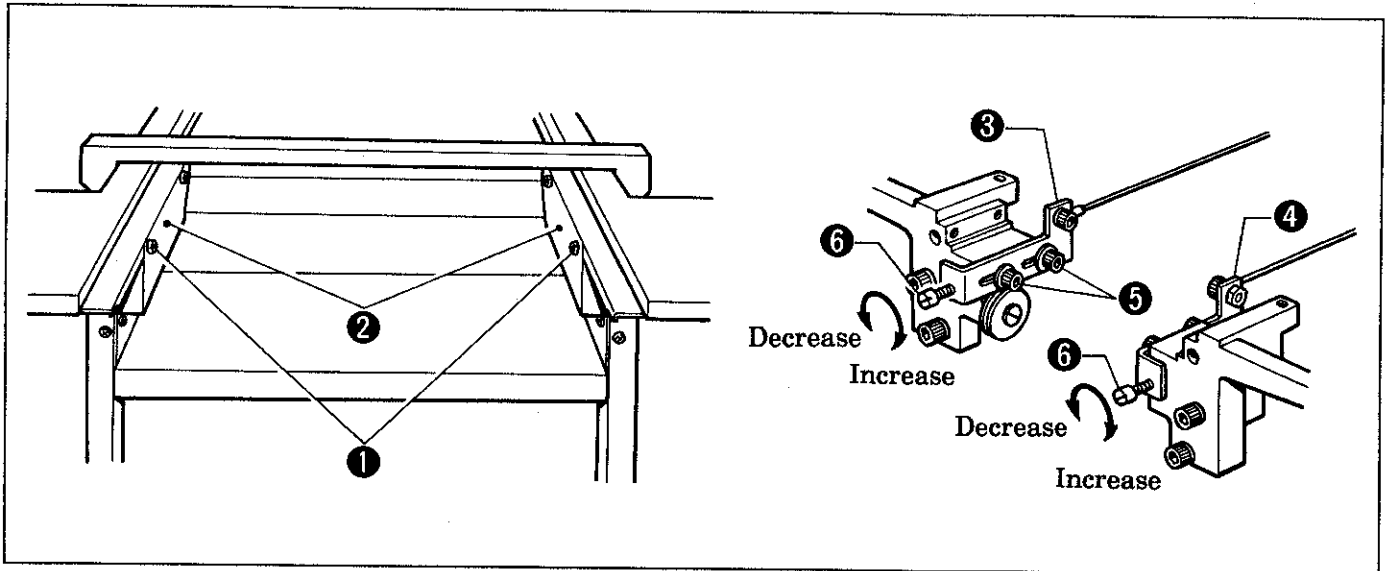

- 1) Remove the seven screws ① and the two covers (LR,LL) ②.
- 2) Loosen two screws ⑤ of both hook (LY) ③ and hook (RY) ④.
- 3) There are two stoppers (U) ⑥ on the right and the left sides. Turning them clockwise will increase the tension and turning them counterclockwise will decrease the tension.
- 4) When the tension is proper, tighten screw ⑤.
- 5) After tightening screw ⑤, firmly retighten stopper (U) ⑥ so there is no looseness.

## 8 Adjusting thread breakage detect stud

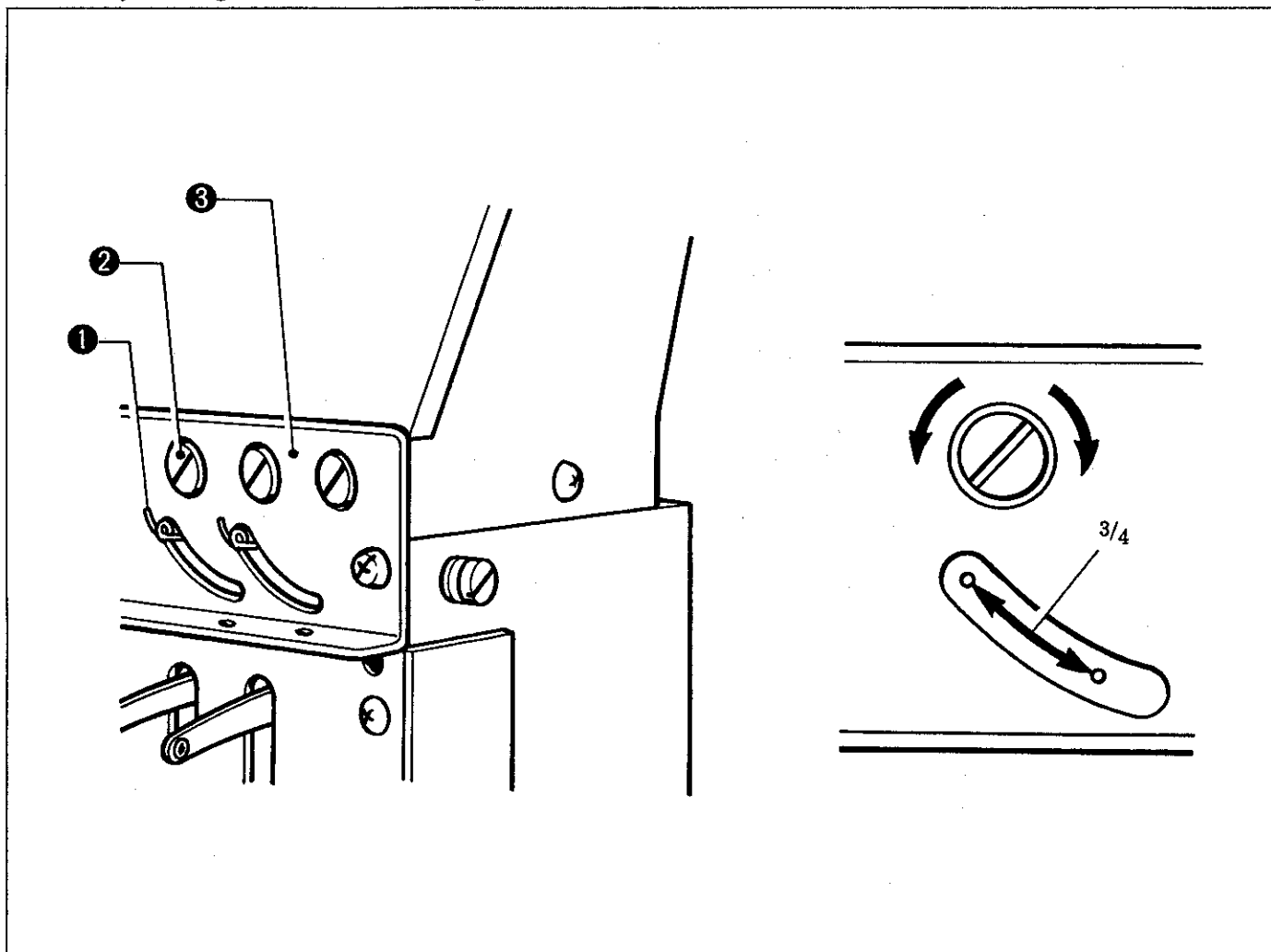

When the needle thread is pulled near the needle and the thread which moves the thread breakage detect stud ① is slowly returned, the thread breakage detect stud ① should return to its position smoothly. Adjust the tension by moving shaft no.1 ② right or left.

(Adjust so that the spring moves within 3/4 of the hole ③ of the 2-stage thread guide)

NOTE: When #120 thread is used, the needle thread tension should be from 60-120g.

## 9 Adjusting bobbin winder

### 1. Positioning bobbin winder claw stud screw

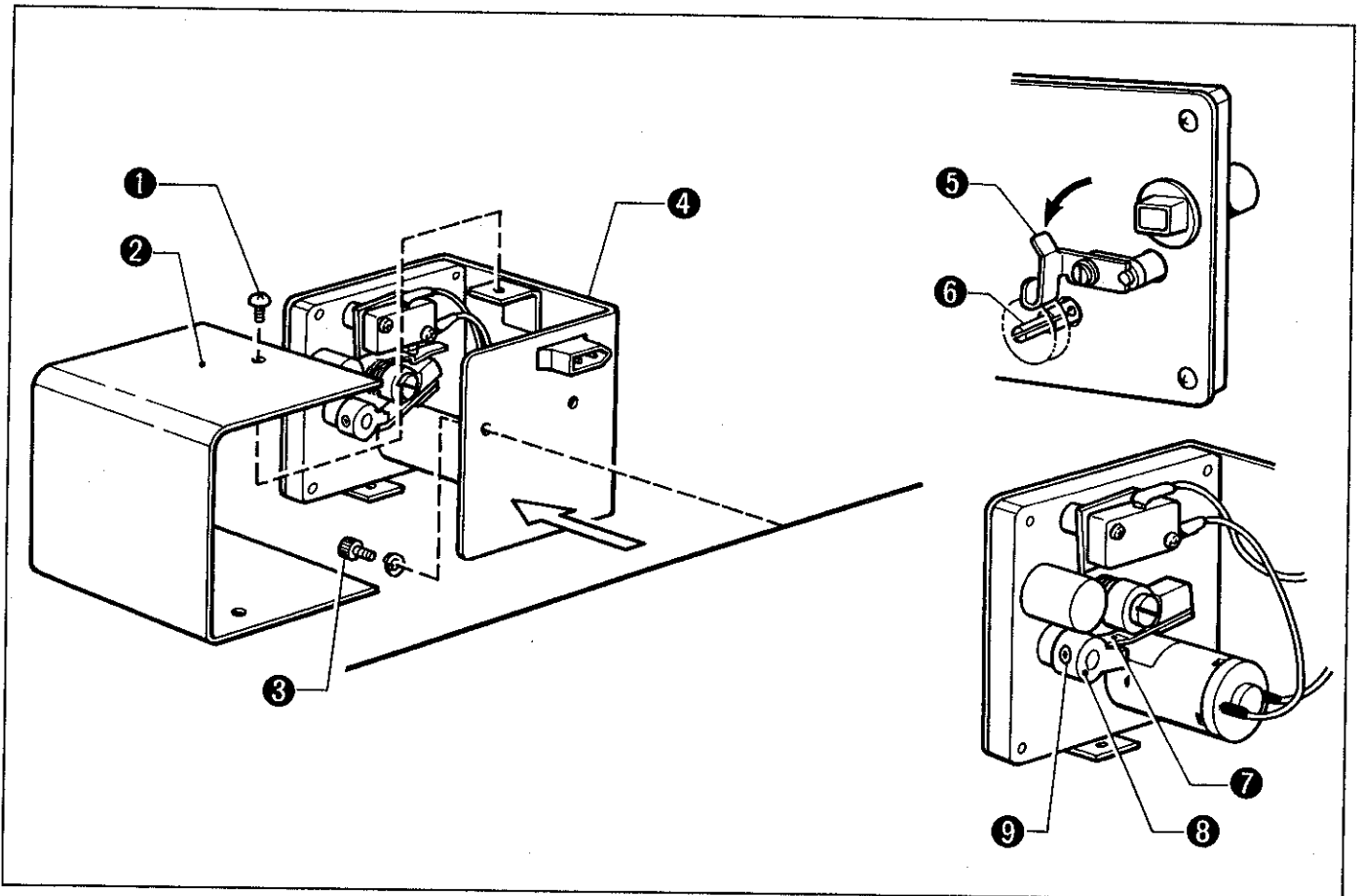

- 1) Remove the three screws ① and the bobbin winder cover ②.  
Remove the two screws ③ and the bobbin winder equipment assembly ④.
- 2) Move the bobbin presser ⑤ toward the bobbin winder shaft ⑥. Stop moving just before it reaches the position where thread-winding ends.
- 3) Tighten the two screws ⑨ so that the plate spring ⑦ is at the stepped section of the bobbin winder claw ⑧.

### 2. Positioning button presser

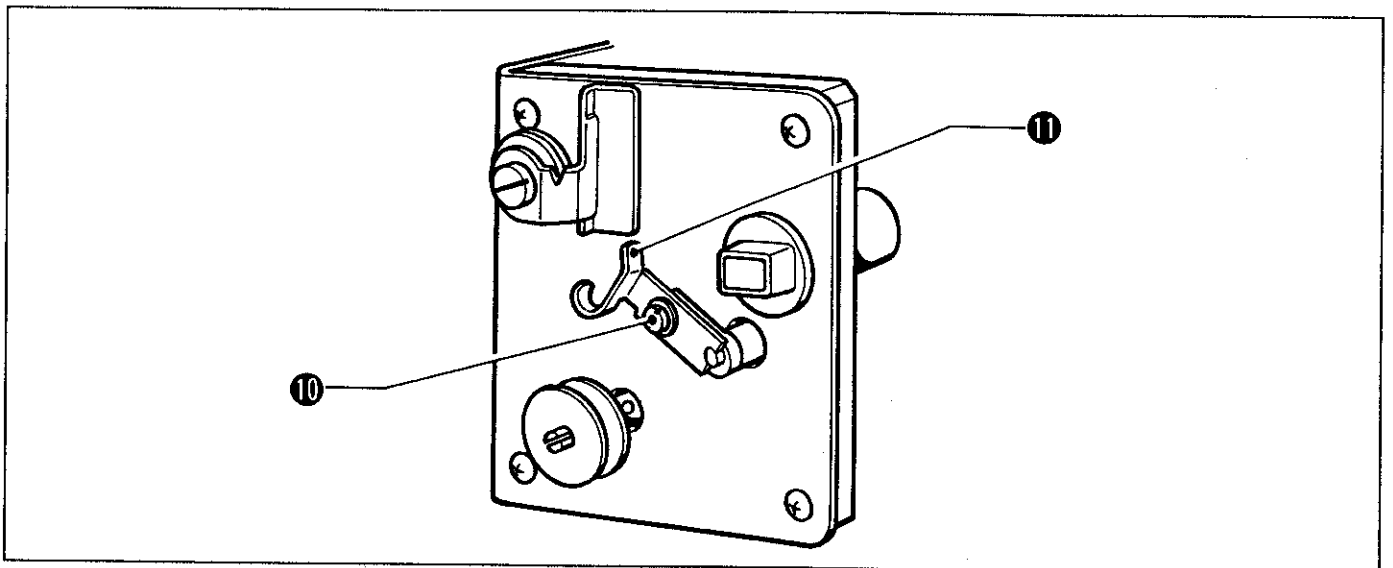

Loosen the screw ⑩ and adjust the bobbin presser ⑪ so that the proper amount of thread can be wound on the bobbin.

## 10 BAS-410 test mode

The BAS-410 main menu contains a test mode function. Although the test options will not be displayed, pressing the number <0>key will start test mode operation.

### 1. Explanation of test mode display



### 2. Explanation of P-ROM version

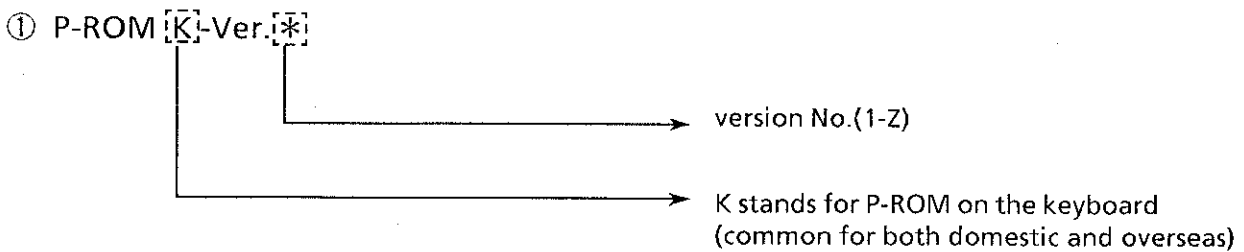
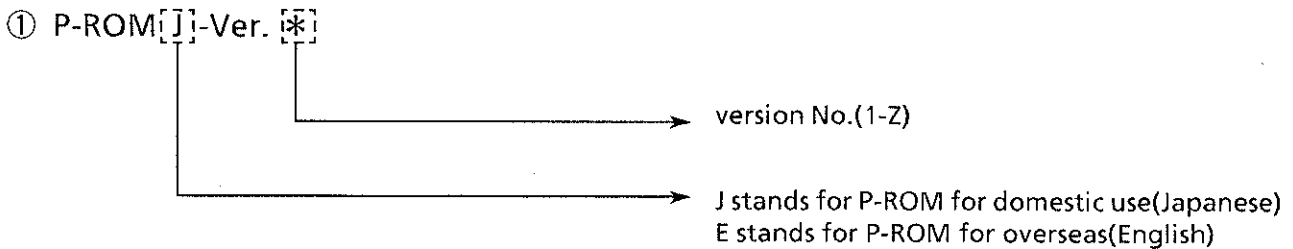

### 3. Explanation of test menu

1)

① E n c o d e r

The menu for adjusting the needle position detecting synchronizer on the machine upper shaft.

2)

② T r a v e l

The menu for adjusting the position of the overtravel sensor.

Pressing alphanumeric keys <1> or <2> will set the machine into one of the test modes.  
After adjustment, press the <END> key to return to the main menu.

## 11 Adjusting synchronizer

The synchronizer detects the needle position and synchronizes the motion of the needle and the holder base.

When the emergency stop operates after the power switch is turned on, or when the machine stops after thread trimming, the needle bar will be released in the jump condition, and the thread take-up will stop at the same position as the other 8 needle bars.

### 1. Adjusting machine stop position (stop signal)

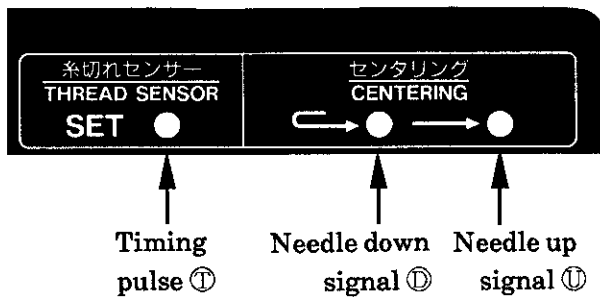
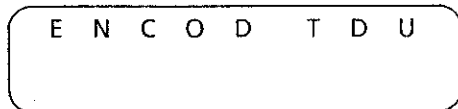
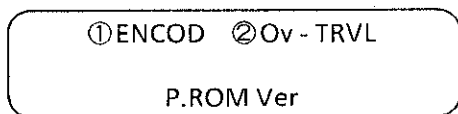

- 1) Turn on the machine power.
- 2) Press the <0> key in either the main menu mode or the editing mode.
- 3) Select ① encoder.

- 4) The green LED located on the upper right of the panel will display the numbers from ① to ③ as shown in the figure on the left.

- ① timing pulse ① ..... blinks every 7.5°
- ② needle down signal ② ..... goes off at -210°
- ③ needle up signal ③ ..... goes off when between -92.5° and 112.5°

92.5° ..... When the needle bar is lowered 20 mm below its highest position.

112.5° ..... When the needle bar is lowered 29 mm below its highest position.

210° ..... When the needle bar is raised 20 mm above its lowest position.

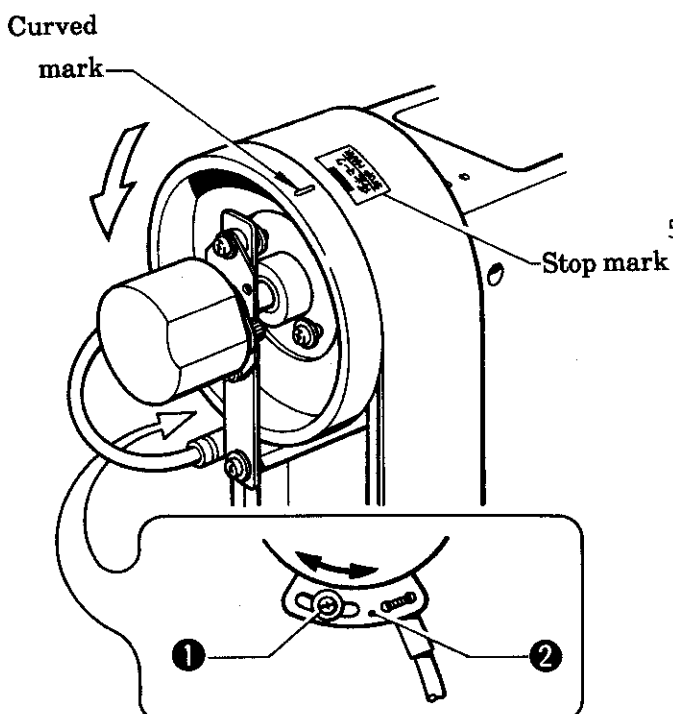

- 5) When the machine pulley is turned in its normal direction, the needle up signal should go off with the curved mark within the range of the stop mark. Loosen screw ① and adjust the synchronizer assembly ②.

## 2. Adjusting needle down signal

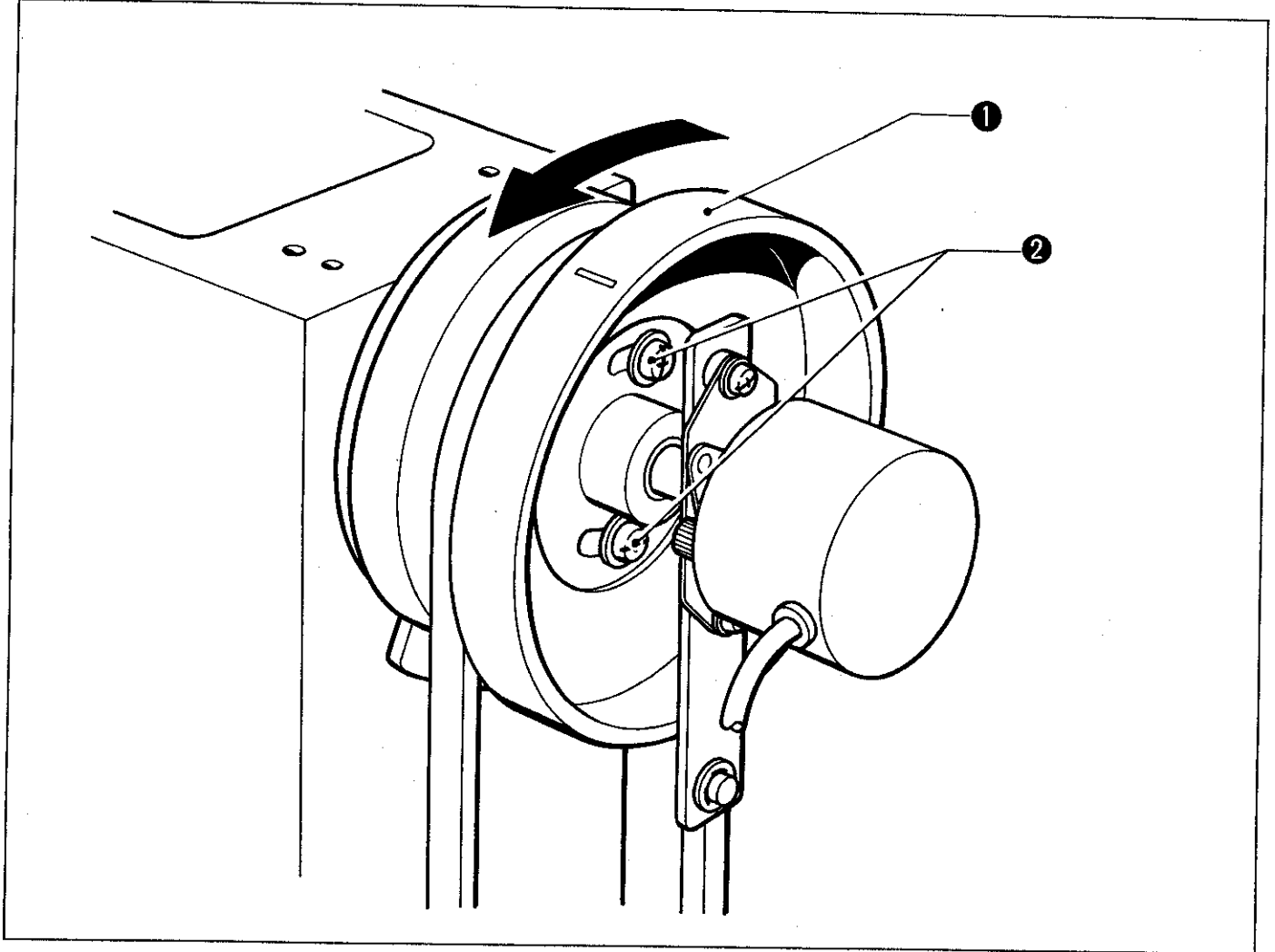

When the machine pulley ① is turned in its normal direction and the needle is 5mm above its lowest position, the lit needle down signal should go off. Loosen the 2 screws ② to adjust.

NOTE: When procedure 1 "Adjusting machine stop position" is done, the needle down signal will move to the same angle. Be sure to adjust the needle down signal when machine stop position has been adjusted. When only the needle down signal is adjusted, the machine stop position does not need to be adjusted.

# LUBRICATION

## 1 Machine head

Lubrication is necessary for keeping the machine in good condition.

Everyday before using the machine, add 1-2 drop(s) of oil at each location in the figure marked by an arrow.

NOTE: ① Be sure to use Brother- specified sewing machine oil for lubrication.

② Overlubrication may cause oil to drip on to the material.

1) Lubricate these six places:

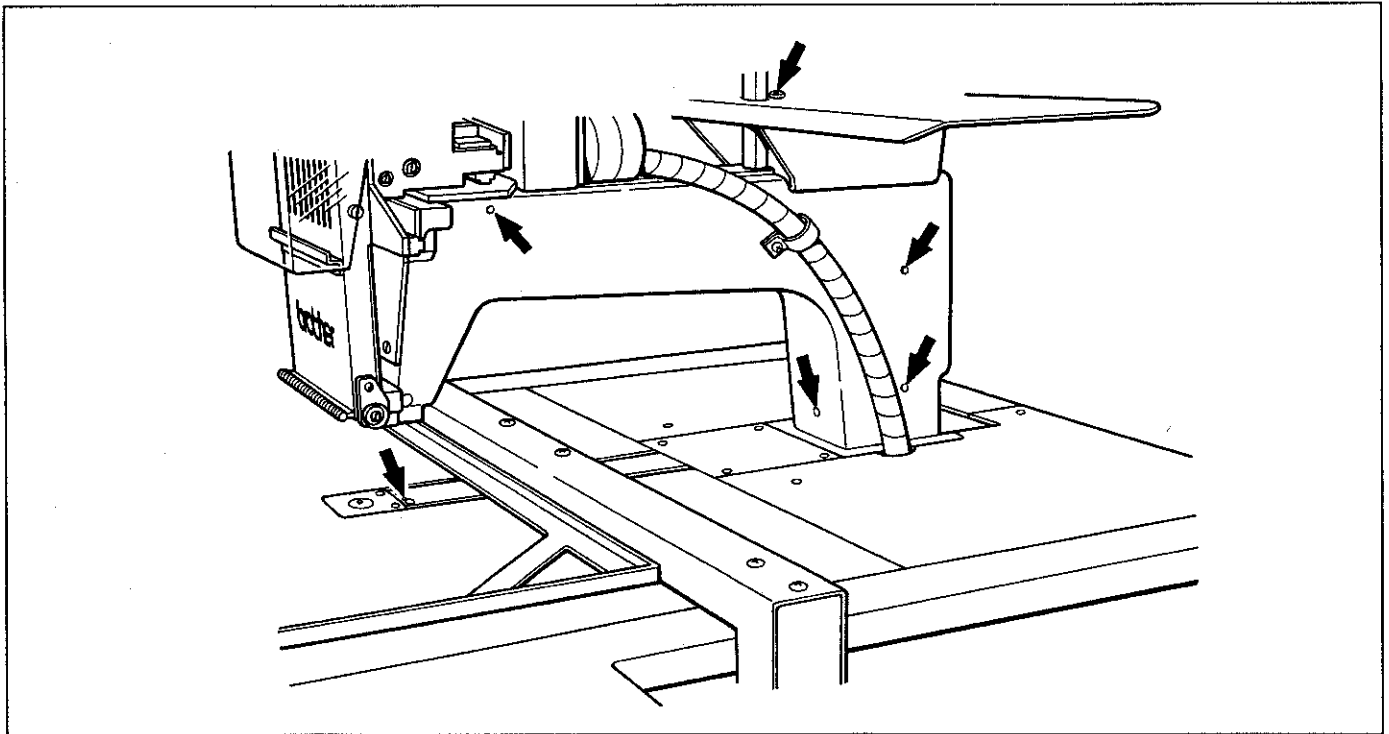

2) Add a drop of oil at the reel of the rotary hook.

NOTE: Do not lubricate aside from the rotary hook.

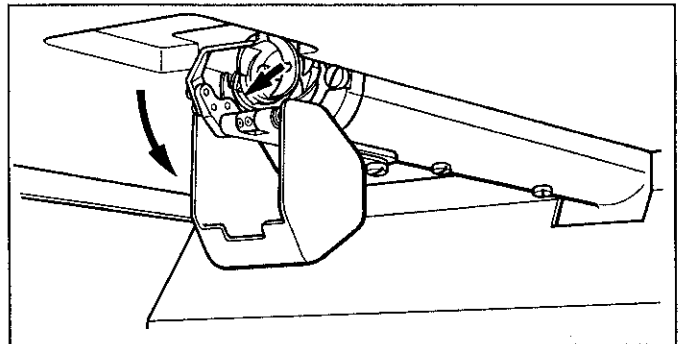

3) Lubricate two places on each needle on the needle bar. (18 places should be lubricated in all.)

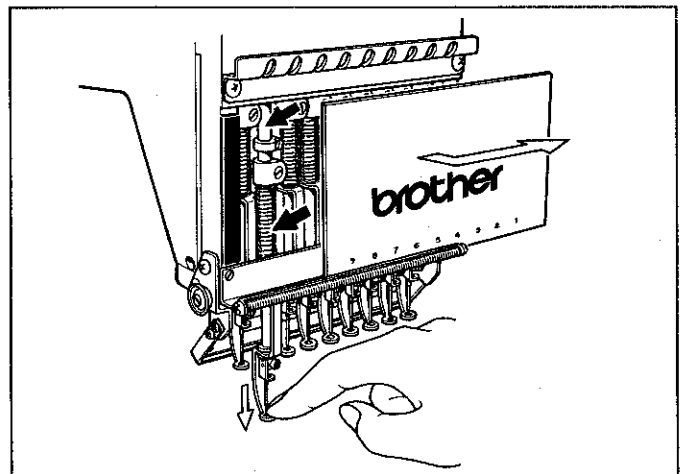

## 2 Feed-guide mechanism

Linear guide rail: X- axis

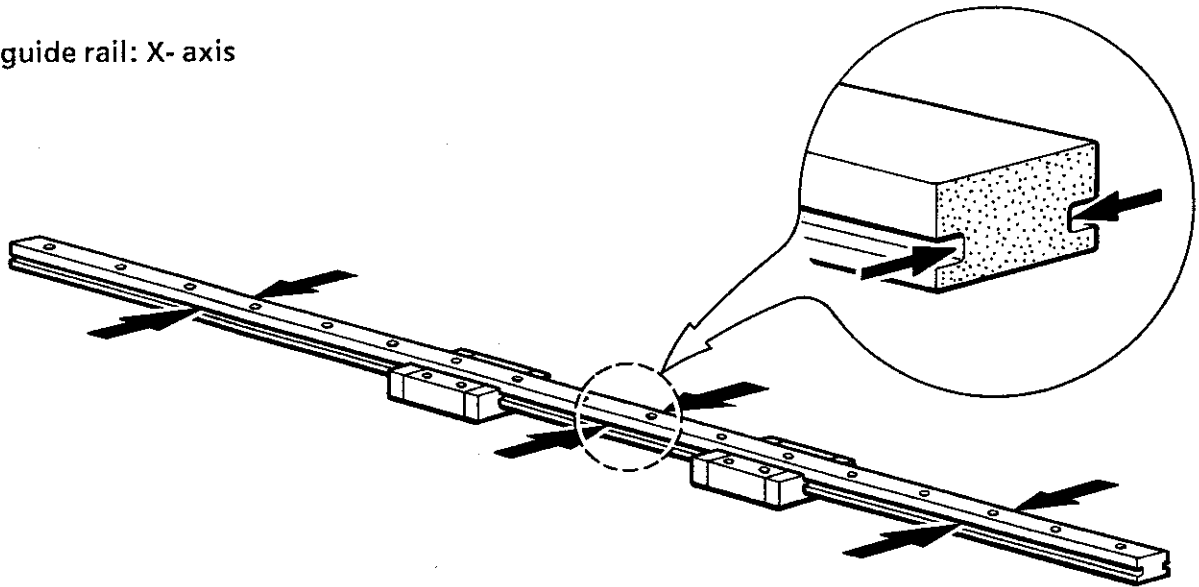

Linear guide rail: Y- axis

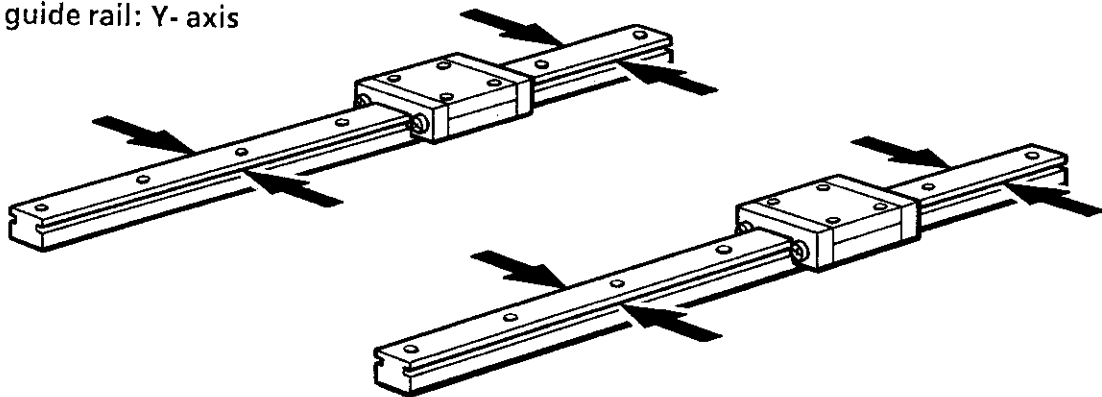

NOTE 1: For lubrication, use Brother- specified grease tank 30.

NOTE 2: Be sure to lubricate every 6 months.

NOTE 3: After applying grease to the X-Y guide rail , move the X carriage right and left 2-3 times.

NOTE 4: Before applying grease, remove covers to make the work easier.

# REPLACING AND ADJUSTING PARTS

## 1 Removing and adjusting machine head (1)

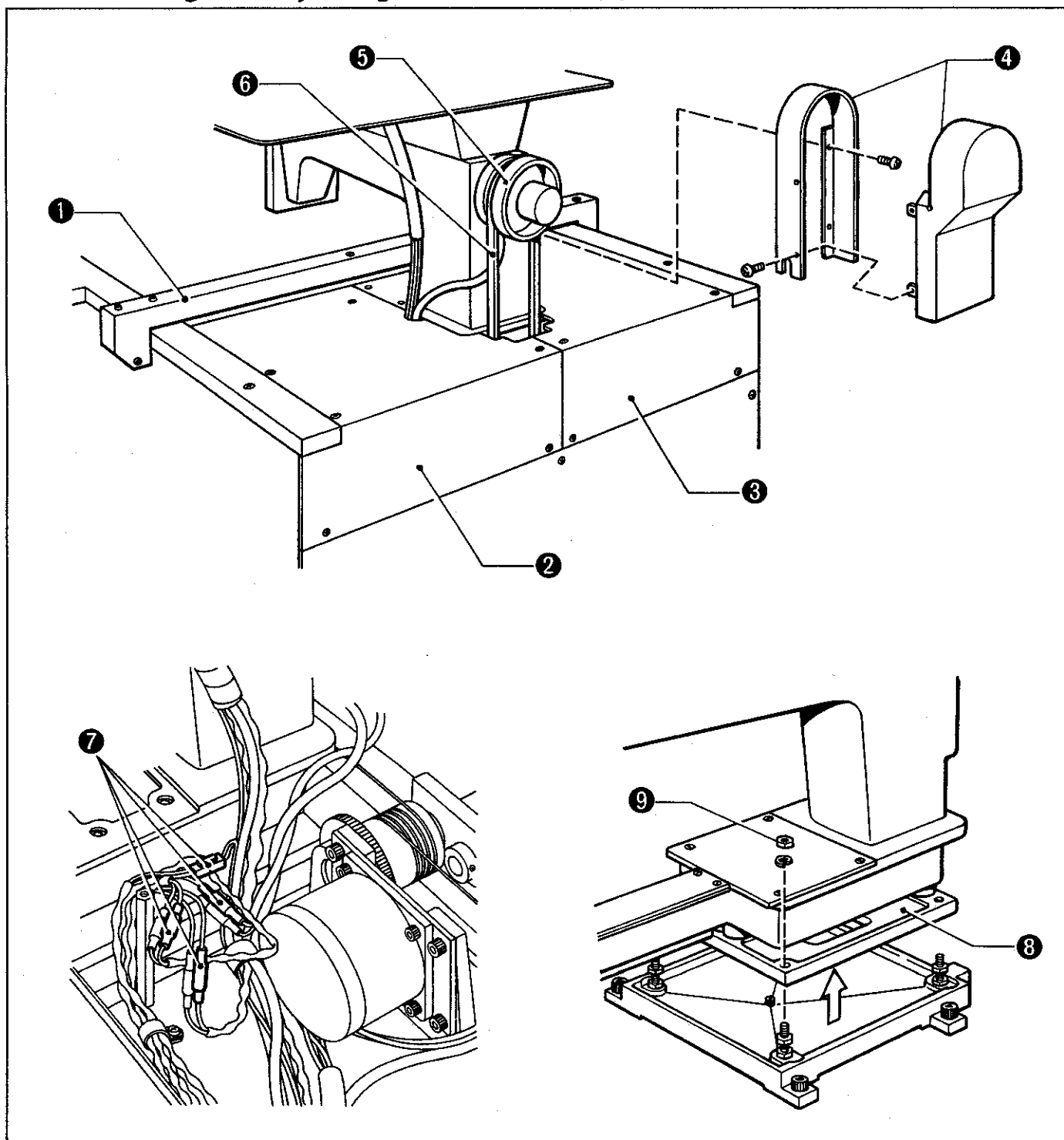

- 1) Remove the X-carriage cover ❶, table (RR) ❷, table (RL) ❸, and the belt cover ❹ in that order.
- 2) Remove the belt ❺ from the pulley ❻.
- 3) Remove the wires ❼ from the circuit board, synchronizer, and the earth.
- 4) Loosen the 4 nuts ❸ securing the sewing machine base ❸. With the sewing machine base ❸ attached to the machine head, remove the machine head.

## 2 Removing and adjusting machine head (2)

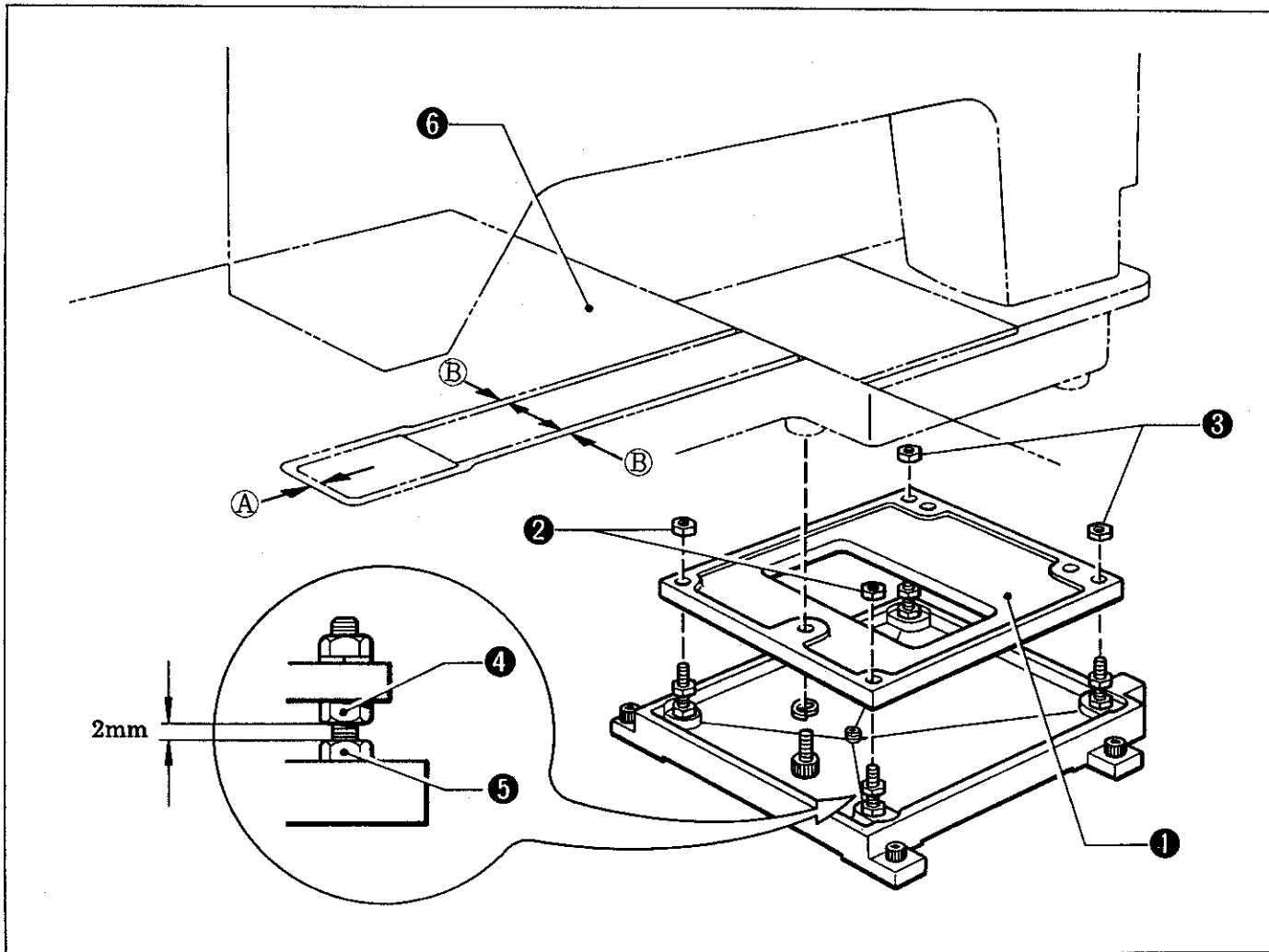

- 1) Use the 4 nuts ② and ③ on the base ① to adjust.  
Be sure to have an approximately 2-mm space between nut ④ and nut ⑤ when adjusting.
- 2) The distance from table (C) ⑥ to the end of the cylindrical bed ①, and distance ② should be the same.  
Use the two rear nuts ③ to adjust.
- 3) After adjustment, tighten the 4 nuts ② and ③.

### ③ Removing needle bar case

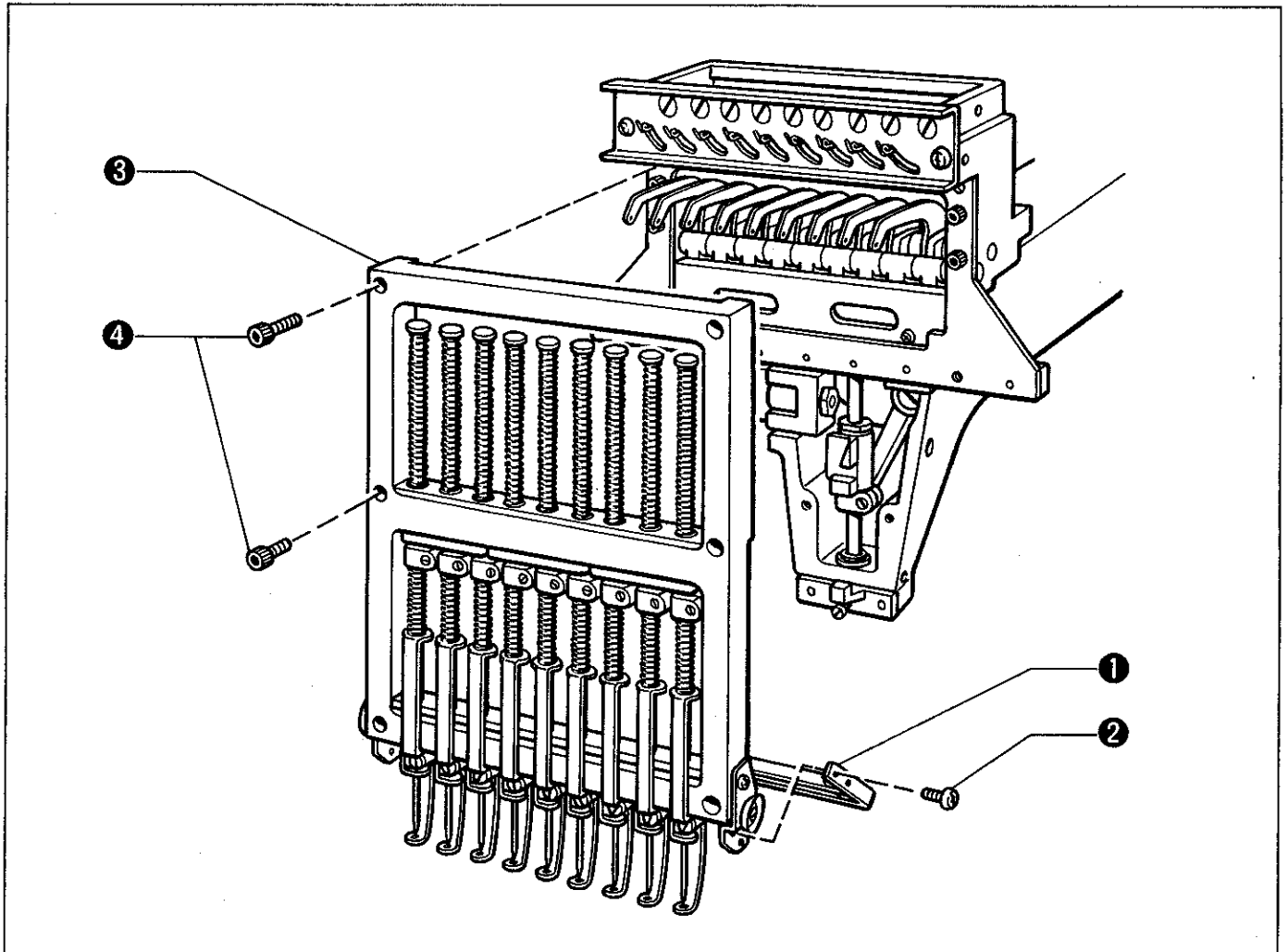

Before replacing parts related to the needle bar mechanism, be sure to remove the needle bar case.

- 1) Loosen the four screws ② of the thread presser base ①.
- 2) Remove the four screws ④ of the needle bar case ③ and the case.
- 3) Adjust the needle bar case ③ so that it moves right and left slightly when attached with four screws.

#### 4 Replacing up and down motion parts

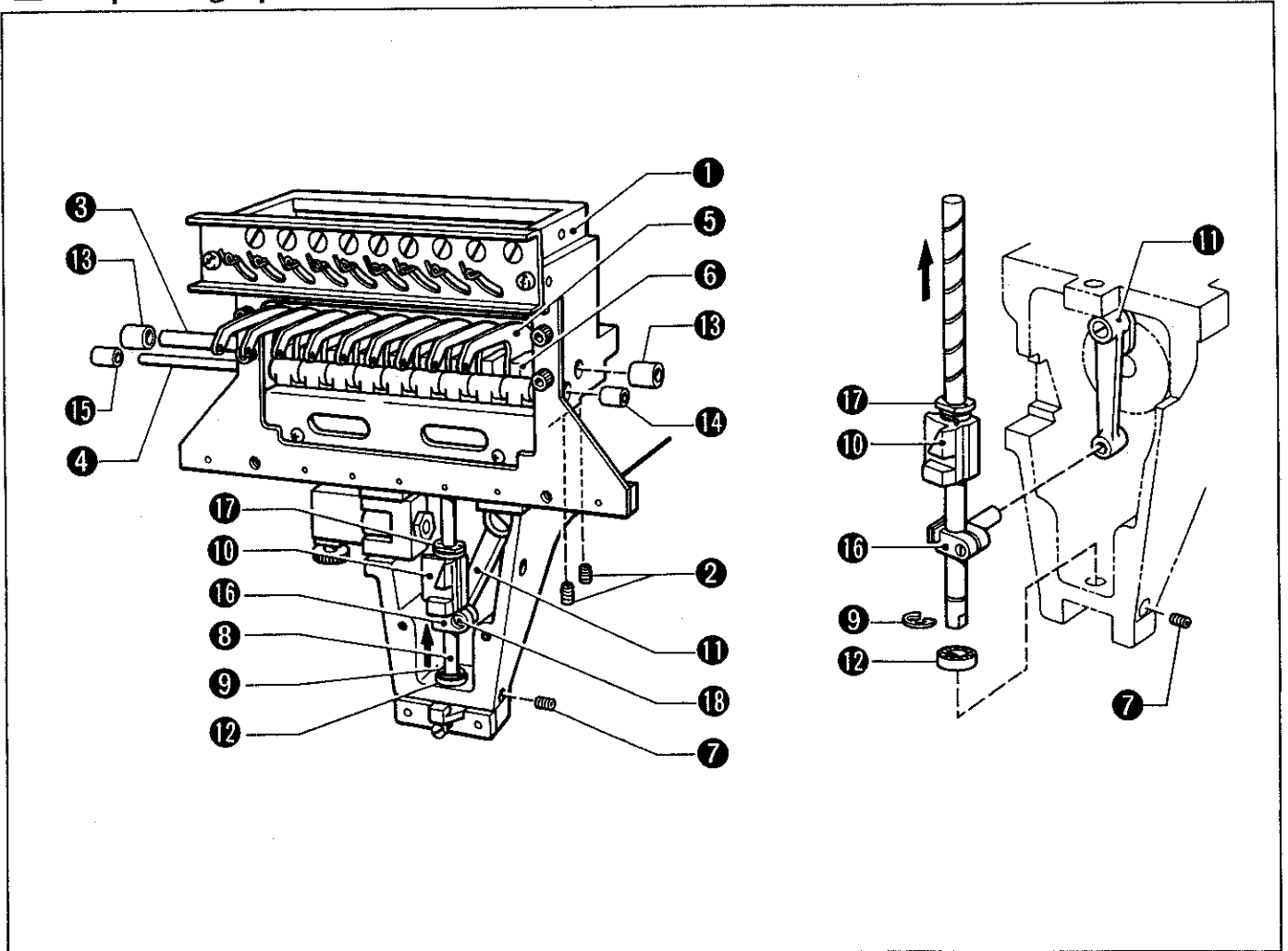

- 1) Loosen the four screws ② on the right and the left sides of the bottom of the thread take-up base ①.
- 2) Move the thread take-up shaft ⑤ and the thread take-up supporter shaft ④ 30 – 40mm, and remove 1 or 2 thread take-up(s) ⑤ and thread take-up supporter(s) ④.
- 3) Loosen the screw ⑦ on the bottom of the right side of the arm.  
Remove the E ring ⑨ attached to the main needle bar ③, then pull out the main needle bar ③ from above.
- 4) Remove the up and down motion parts ⑩ from the connecting rod ⑪.
- 5) When assembling, reverse the above procedure.

NOTE1: When attaching the main needle bar ③, secure the bearing ⑫ by pressing it with the E ring ⑨ which will be attached to the main needle bar ③.

NOTE2: When attaching the thread take-up ⑤ and the thread take-up supporter ④, fix them so there is a 0.5-mm space between ⑬ and ⑭ or ⑮ and ⑯.

NOTE3: Using a thickness gauge, ensure that there is a 0.5-mm space between the up and down motion parts clamp ⑮ and the up and down motion parts clamp ⑮ so it is perpendicular to the base needle bar bush ⑰. Tighten the set screw ⑰.

## 5 Replacing jump solenoid

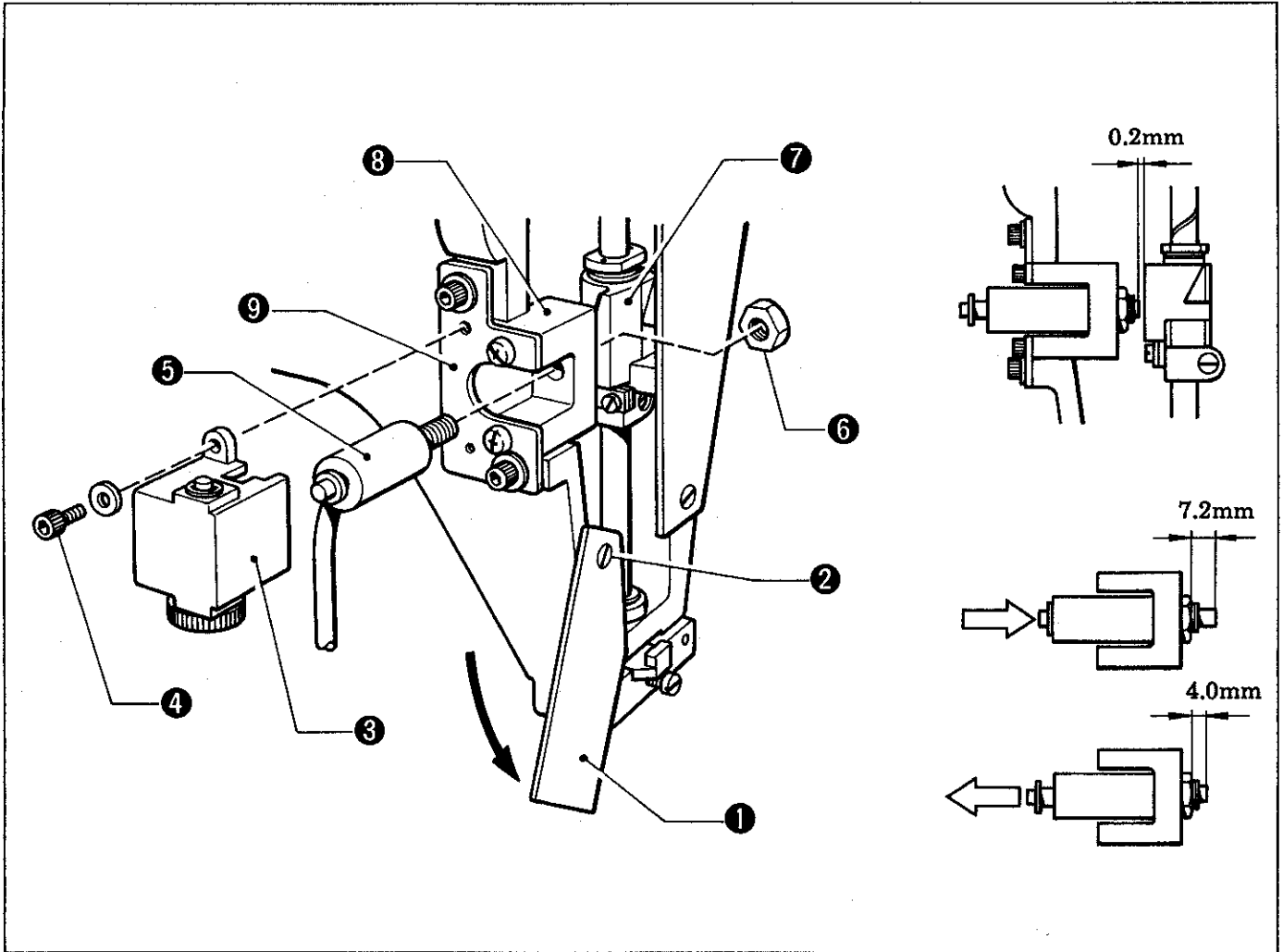

- 1) Loosen the set screw ② of the front cover (L) ① and move the cover (L) ① to the bottom left.
- 2) Remove the two set screws ④ from the solenoid cover ③ and the cover.
- 3) Remove the nut ⑥ of the solenoid ⑤. Then, remove the solenoid while turning it.
- 4) When assembling, reverse the above procedure.

NOTE:1 The end of the solenoid ⑤ should not contact the up and down motion parts ⑦. Adjust the distance between them to approximately 0.2mm by moving nut ⑥.

Adjustment references:

When the solenoid rod is pushed, the distance between the end of the rod and the nut is 7.2mm.

When the solenoid rod is returned, the distance between the end of the rod and the nut is 4.0mm.

NOTE:2 To avoid mispositioning of the solenoid, do not remove the solenoid bracket ③ or the bracket base ⑨.

## 6 Attaching X wire

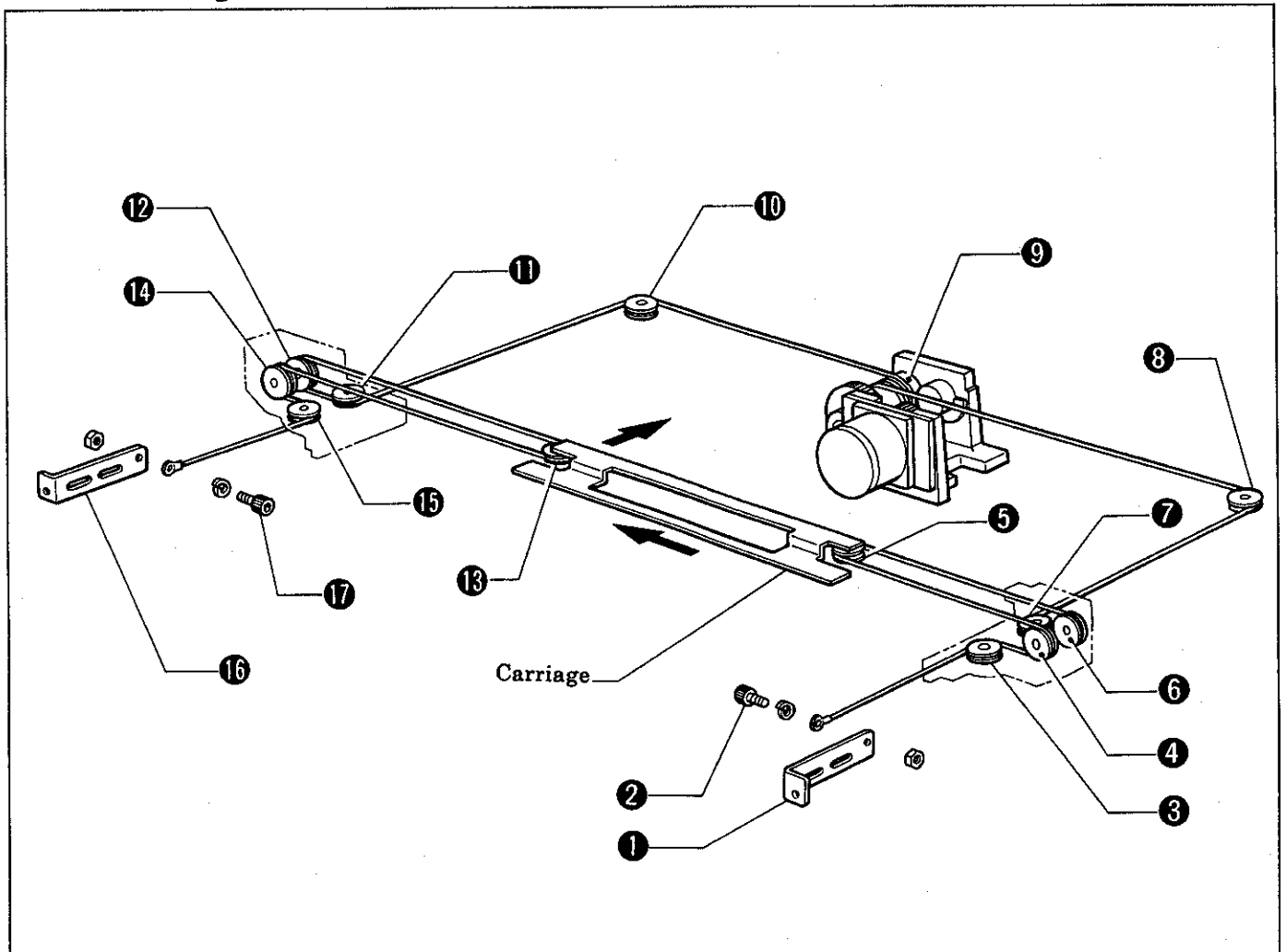

- 1) Position the carriage in the back, toward the left of the machine, making sure it does not move.
- 2) Attach the wire end (the end closer to the ball) to the hook (RX) ① with bolt ②.
- 3) Feed the wire around pulley ③ from the left side, then under pulley ④. Then feed it behind pulley ⑤ from the left side, and over pulley ⑥. Then, feed the wire around pulley ⑦ from the left, and finally wind it around pulley ⑧ from the right.
- 4) After winding the wire around pulley ⑧, feed some slack into the wire. Then, put the ball on the wire into the hole of the wire drum (X) ⑨. Fit the wire completely into the groove, then wind the wire 8 times around the wire drum.
- 5) Feed the wire around the back of pulley ⑩, then around pulley ⑪ from the left.
- 6) Wind the wire onto pulley ⑫ from below, then around pulley ⑬ from the left.
- 7) Wind the wire over pulley ⑭ from above, then around pulley ⑮ from the left. Attach the wire to the hook (LX) ⑯ with bolt ⑰.

NOTE: Be careful not to scratch the wire. The wire is coated with resin and a scratch may decrease its durability.



# EXPLANATION OF CIRCUIT BOARDS

## 1 Positions of circuit boards

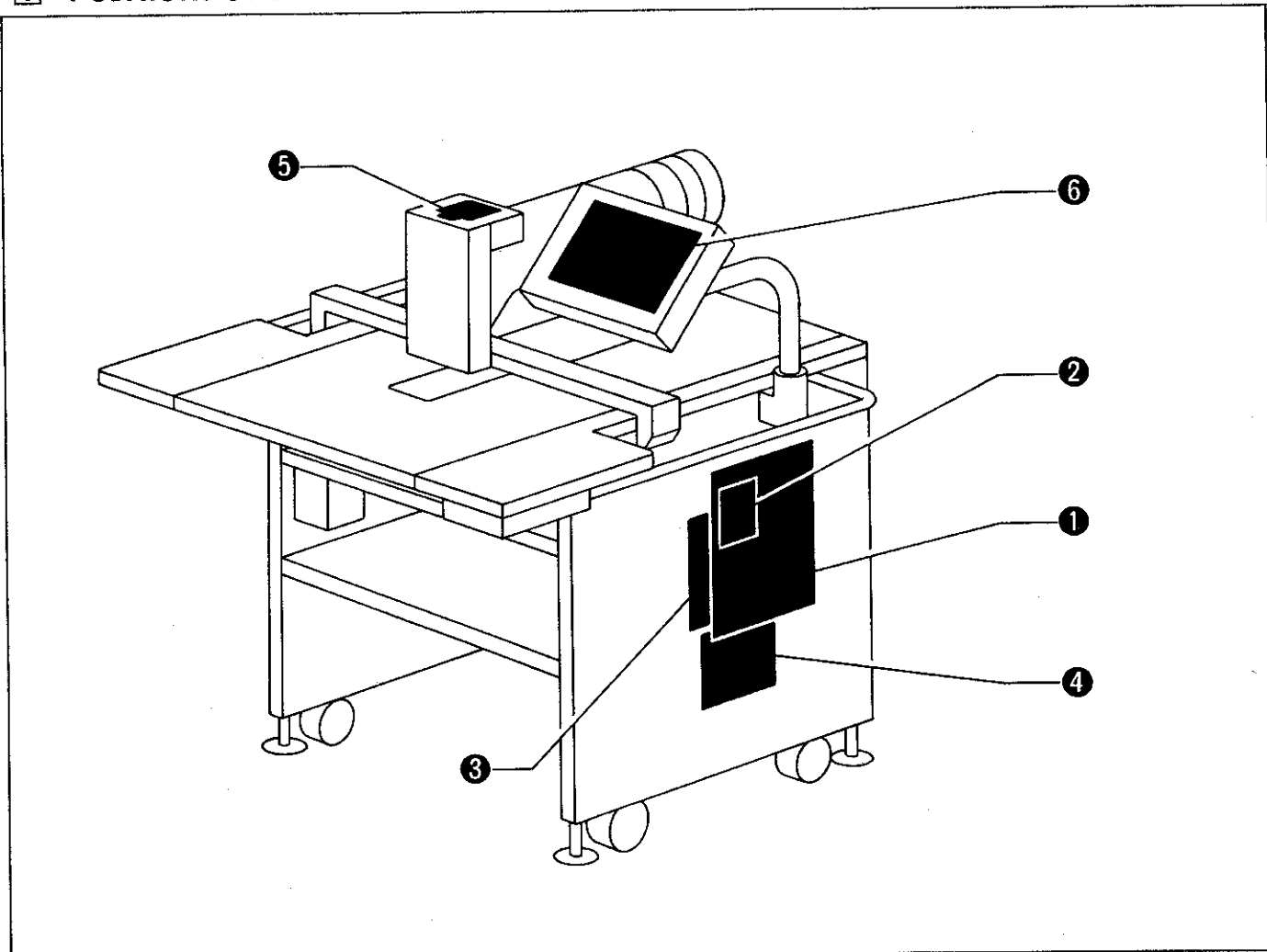

① Main circuit board  
④ Motor circuit board

② RS plug circuit board  
⑤ Synchronizer circuit board

③ PMD circuit board  
⑥ Key board circuit board

## 2 Replacing circuit boards

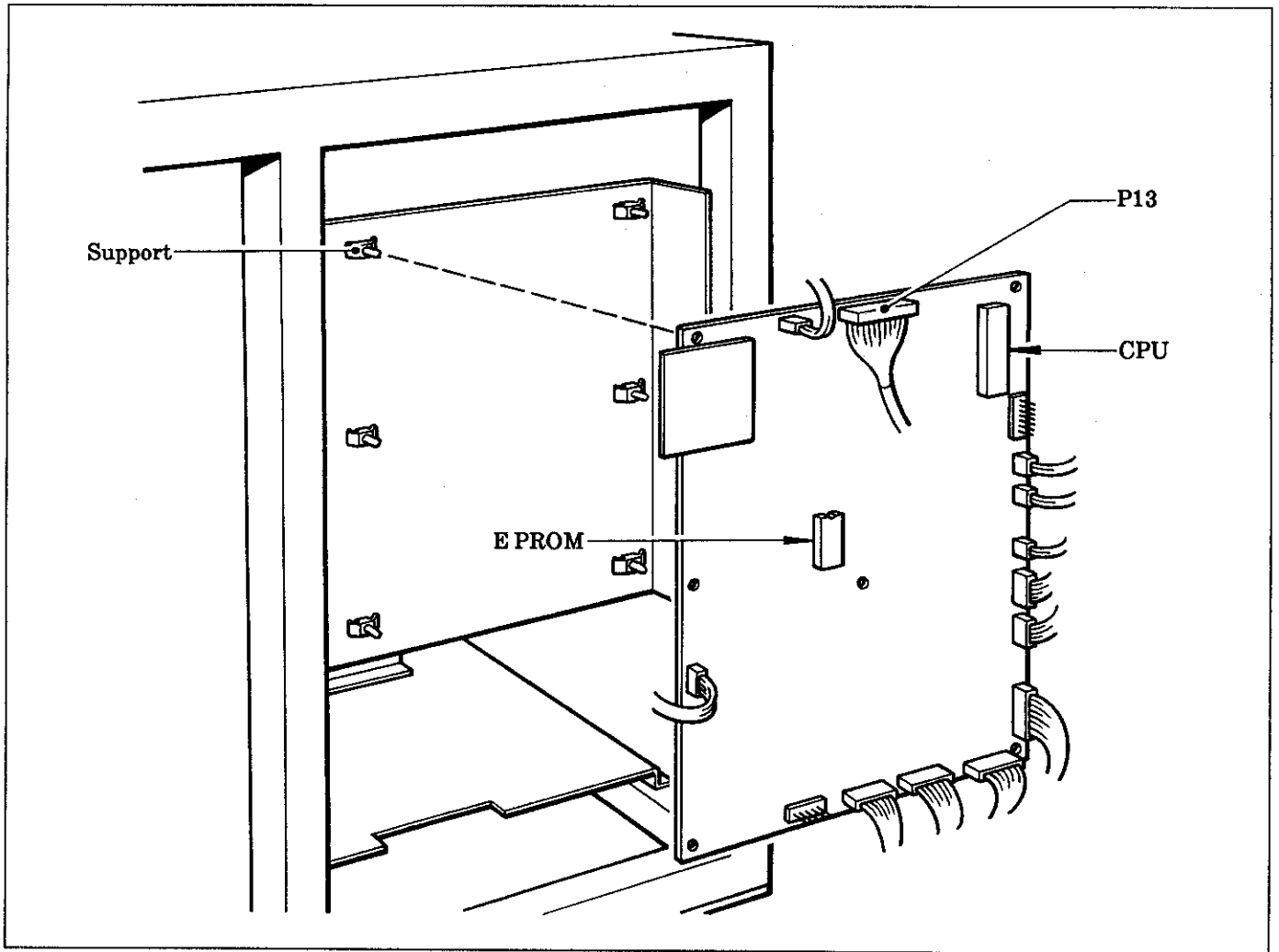

### Main circuit board

Be sure to turn off the power and open the cover before replacement.

- 1) Disconnect 15 connectors.
- 2) Press the 6 circuit board support clamps inward and remove the main circuit board from the supports. Replace the main circuit board.
- 3) Place new main circuit board on the supports. Secure the circuit board by pushing down near each of the support clamps until it snaps into position.
- 4) Connect the connectors while supporting the circuit board from the back side. Be sure not to treat the circuit board forcefully.

NOTE1: When replacing connectors, treat them carefully. Do not pull on the wires when detaching the connectors.

NOTE2: Note that the flat cable P13 is directional (refer to the arrow). It can not be inserted in the opposite direction.

NOTE3: Treat the circuit boards carefully. MOS-IC in the circuit boards is easily damaged by static electricity. Also, do not touch IC pins.

NOTE4: Do not bend circuit boards. The circuit pattern or IC may be broken by external force due to the large size of the circuit board.

NOTE5: Check that new main circuit board has a CPU(HD64180) and an EP-ROM(27512).

NOTE6: When turning the power on for the first time after replacing the main circuit board, be sure to turn it on holding down the emergency stop switch. This clears the internal memory.

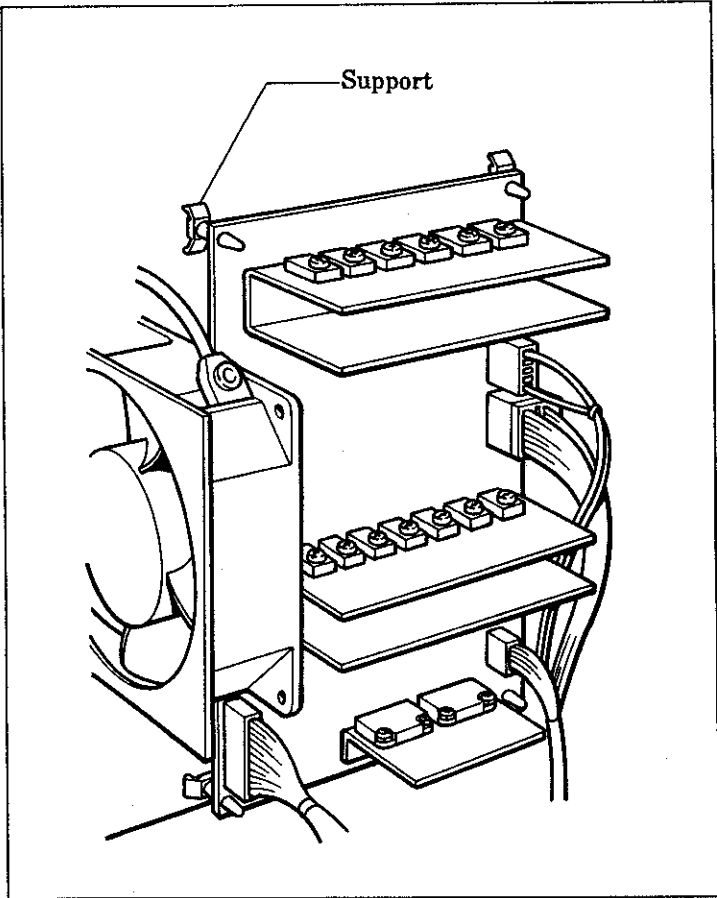

**PMD pulse motor circuit board**

- 1) Disconnect the 4 connectors.
- 2) Push the 5 circuit board supports towards the inside and remove the pulse motor circuit board.  
Replace the pulse motor circuit board.
- 3) Place new pulse motor circuit board on the supports. Secure the circuit board by pushing down near each of the supports. The support tips will snap into position, securing the circuit board.

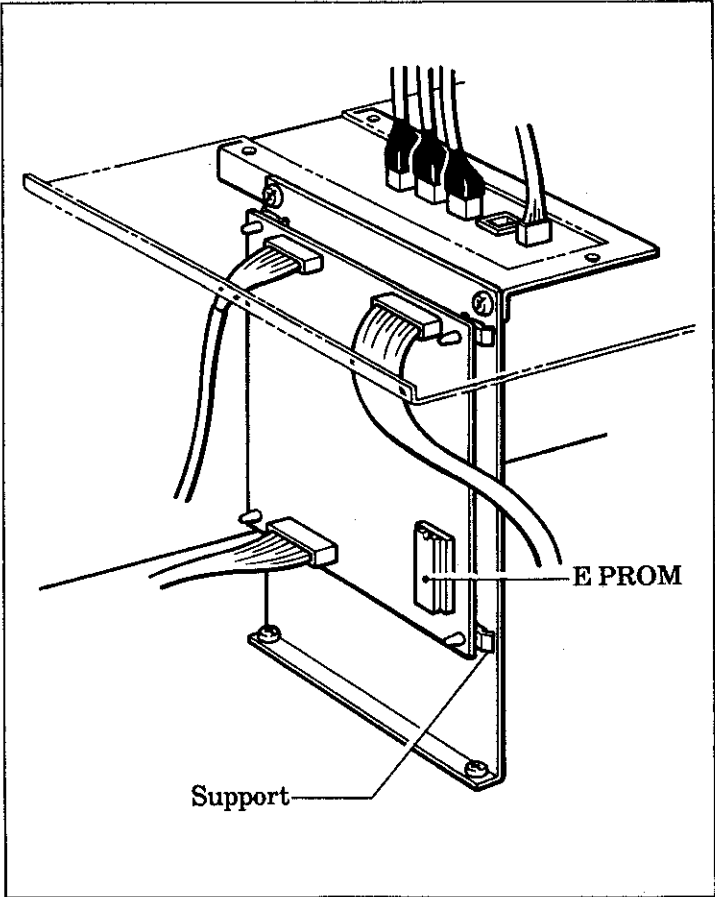

**Machine motor circuit board**

- 1) Disconnect the 3 connectors.
- 2) Push the 4 circuit board supports towards the inside and remove the pulse motor circuit board.  
Replace the pulse motor circuit board.
- 3) Place new pulse motor circuit board on the supports. Secure the circuit board by pushing down near each of the supports. The support tips will snap into position, securing the circuit board.

## Synchronizer circuit board

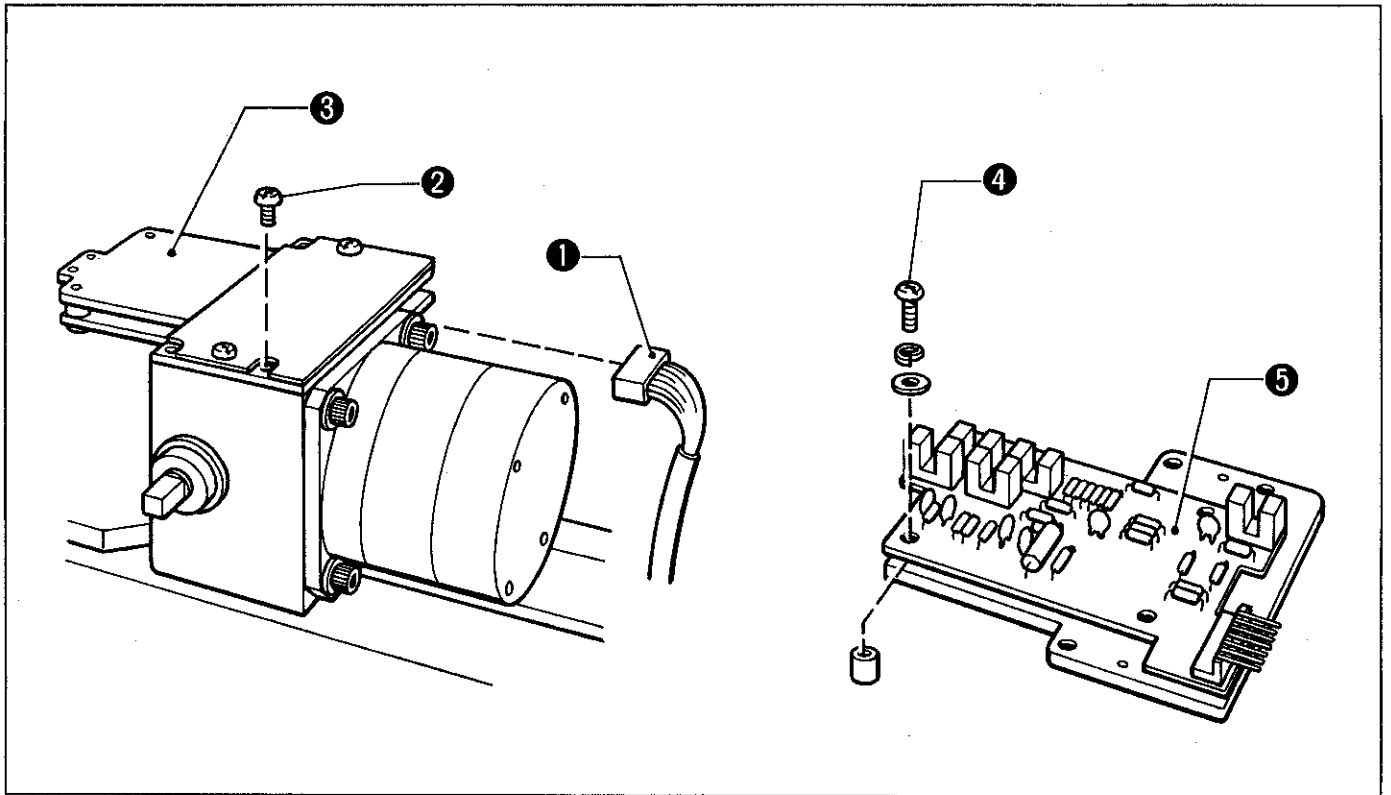

- 1) Disconnect the connector ①.
- 2) Remove the 3 screws ② and the circuit board attachment base ③.
- 3) Remove the 4 screws ④ and the synchronizer circuit board ⑤.

## RS plug circuit board

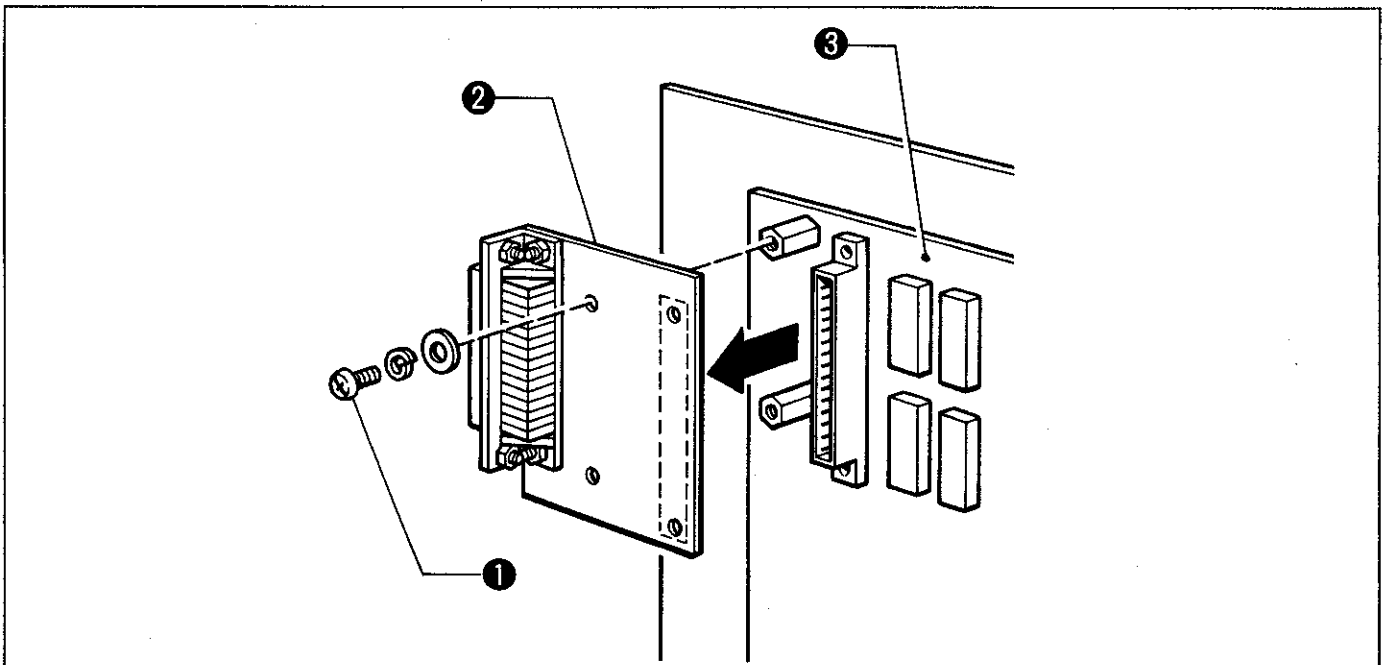

## RS plug circuit board

Remove the 2 screws ① and pull out the RS plug circuit board ② from the main circuit board ③.

## Keyboard circuit board (1)

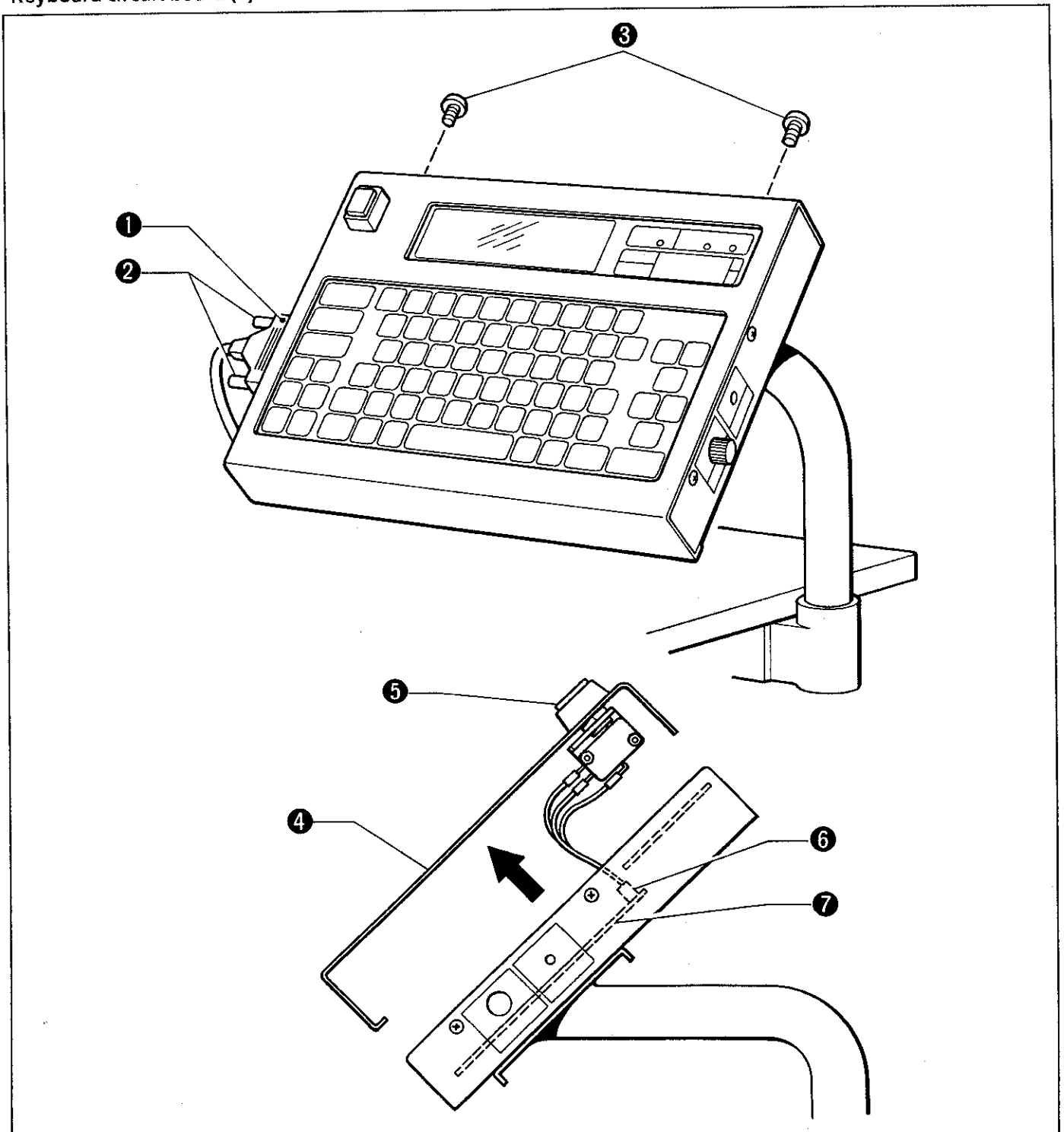

- 1) Manually loosen the two screws ② in the keyboard cable ① and remove it.
- 2) Loosen the two screws ③. Pull the upper part of the panel ④ toward yourself and detach it.  
At this time, do not pull strongly on the EMERGENCY stop switch ⑤ cable.
- 3) Disconnect the EMERGENCY switch ⑤ connector ⑥ from the keyboard circuit board ⑦.

## Keyboard circuit board (2)

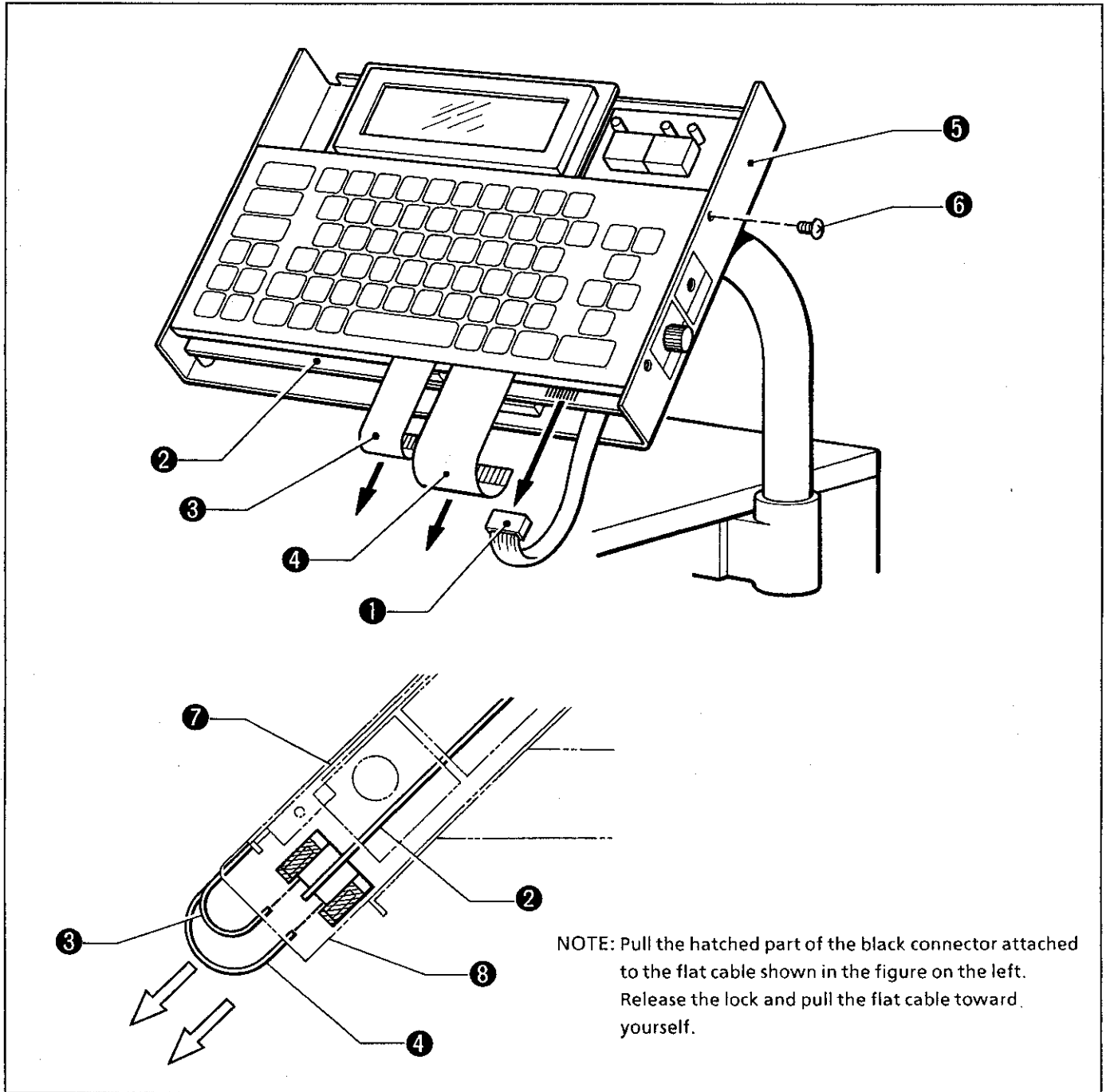

- 4) Disconnect the connector ① from the keyboard circuit board ②.
- 5) Disconnect the flat cables ③ ④ from the keyboard circuit board ②.
- 6) Loosen the four screws ⑥ on the right and left sides of the supporter ⑤. Remove the key sheet ⑦ from the keyboard base ③.

Keyboard circuit board (3)

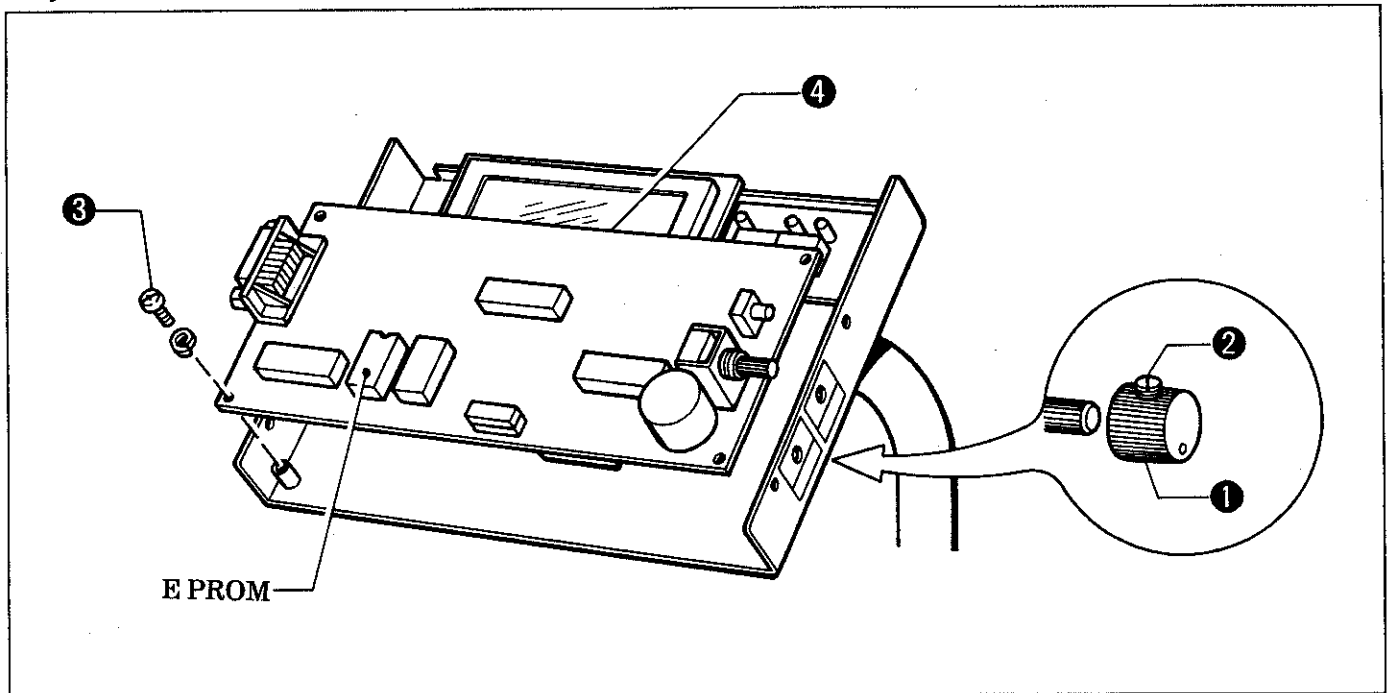

- 7) Loosen the screw ② so that the knob ① can be removed easily. Then, remove the knob ①.
- 8) Remove the 4 screws ③ and the keyboard circuit board ④.
- 9) When assembling, reverse the above procedure. For assembling, note the following points.

NOTE1: Attach the contrast knob ① as follows:

Align the white point of the knob ① with the position line. Tighten the screw ②.

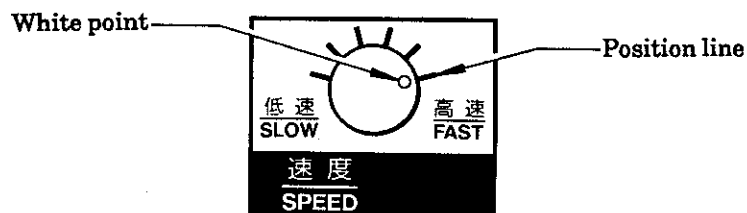

NOTE2: Insert the flat cables ⑤ and ⑥ connectors while the black connector lock is released. Insert the hatched part of the connector to lock it in place.

Pull the flat cables ⑤ and ⑥ lightly to check if they are locked properly.

If either flat cable is loose, the cables may have been improperly inserted into the slots. Release the lock and insert into the slots correctly.

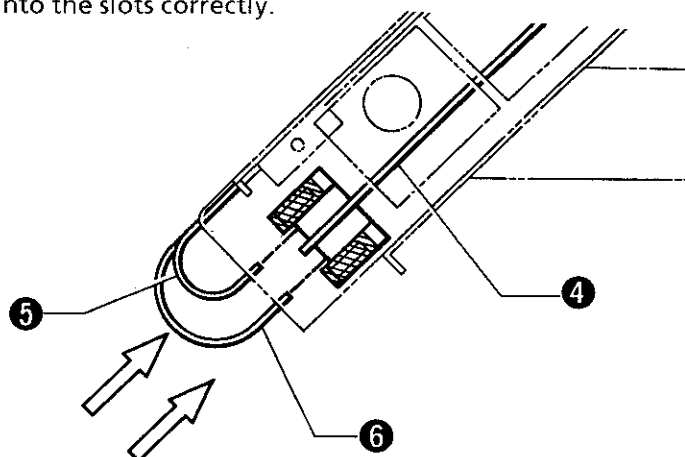

## Keyboard unit

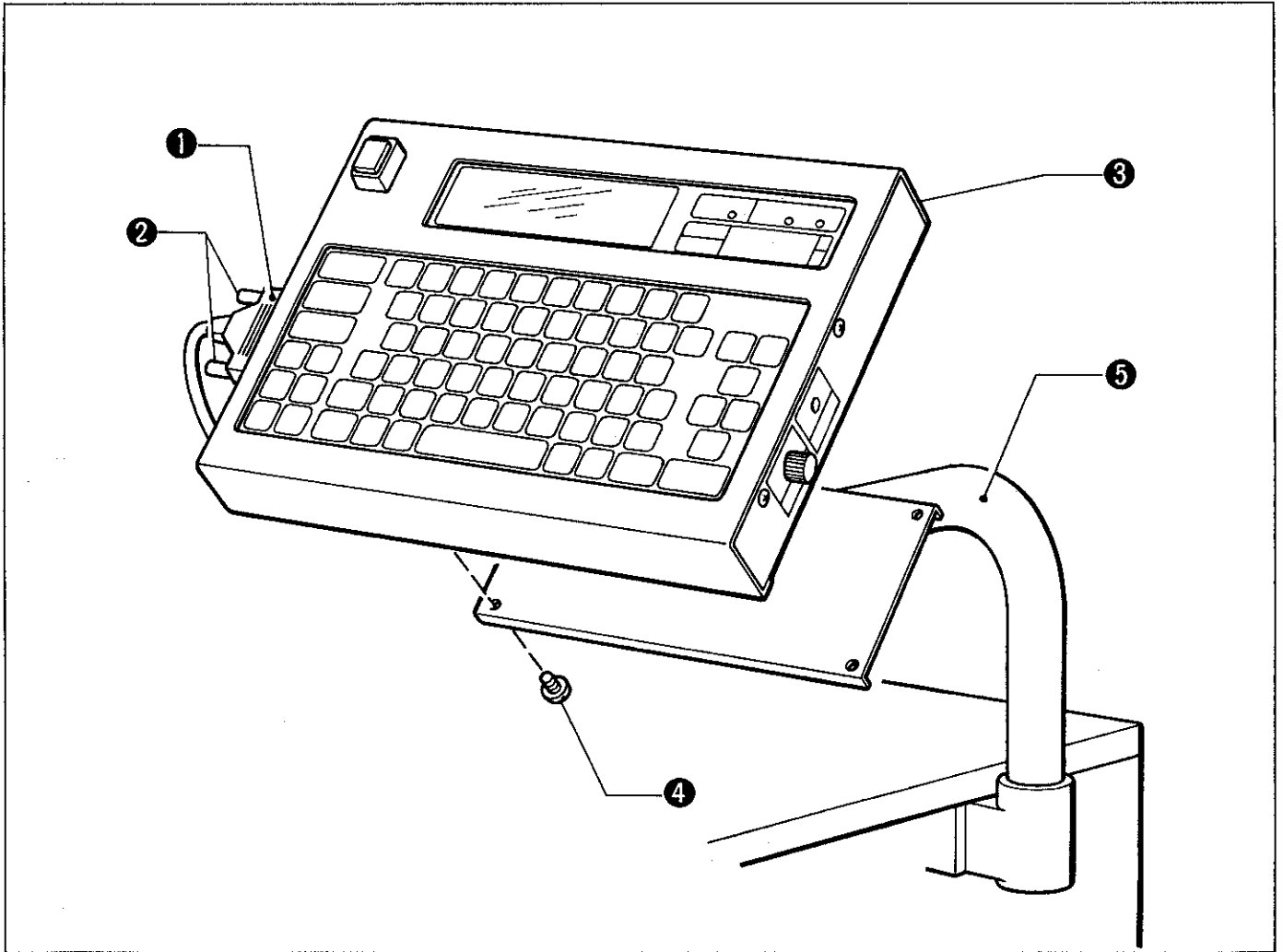

When replacing the whole keyboard unit, follow the procedures below.

- 1) Manually loosen the 2 screws ② in the board cable ① and remove it.
- 2) Remove the 4 screws ④ on the back side of the keyboard unit ③. Then remove it from the keyboard stand ⑤.  
At this time, be careful not to drop the keyboard unit ③.
- 3) When assembling, reverse the above procedure.

### ③ Explanation of fuses

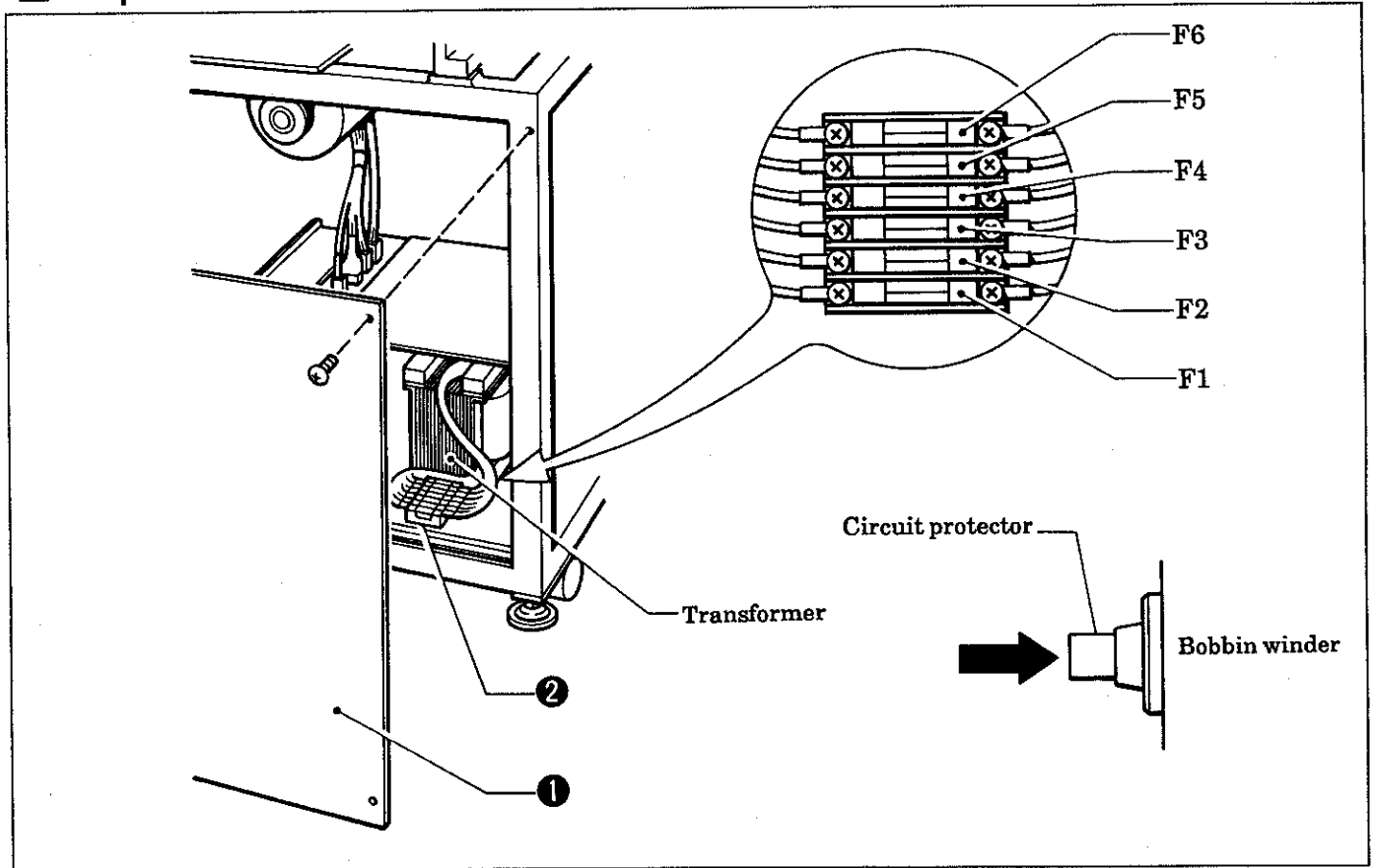

#### 1. Position of fuses

- 1) Remove cover(B) ①.
- 2) There is a fuse holder in front of the transformer in the power supply unit. Six fuses are fixed in the fuse holder ②.

NOTE: Be sure to turn off the power before replacement.

#### 2. Fuse type and capacity

| No. | Fuse type & capacity | Part code  | Reference                |
|-----|----------------------|------------|--------------------------|
| F1  | Fuse 15A             | S02887-000 | for Pulse motor          |
| F2  | Slow blow fuse       | S11705-000 | for Regulator            |
| F3  | Fuse B               | 152565-000 | for Solenoid             |
| F4  | Slow blow fuse       | S11705-000 | for Bobbin winder        |
| F5  | Fuse B               | 152565-000 | for Lamp                 |
| F6  | G Fuse 5A FB         | S08030-000 | for Sewing machine motor |

NOTE: Be sure to use only fuses of authorized types and capacities.

NOTE: If your BAS-410 bobbin winder is equipped with circuit protector, it replaces fuse 4.

NOTE: While the circuit protector is activated, the thread winding motor will not rotate. Let the protector cool for a while before pushing it back. Otherwise, it may trip again.

NOTE: During replacement, tightly attach each fuse into its socket.

#### 4 Explanation of P-ROM

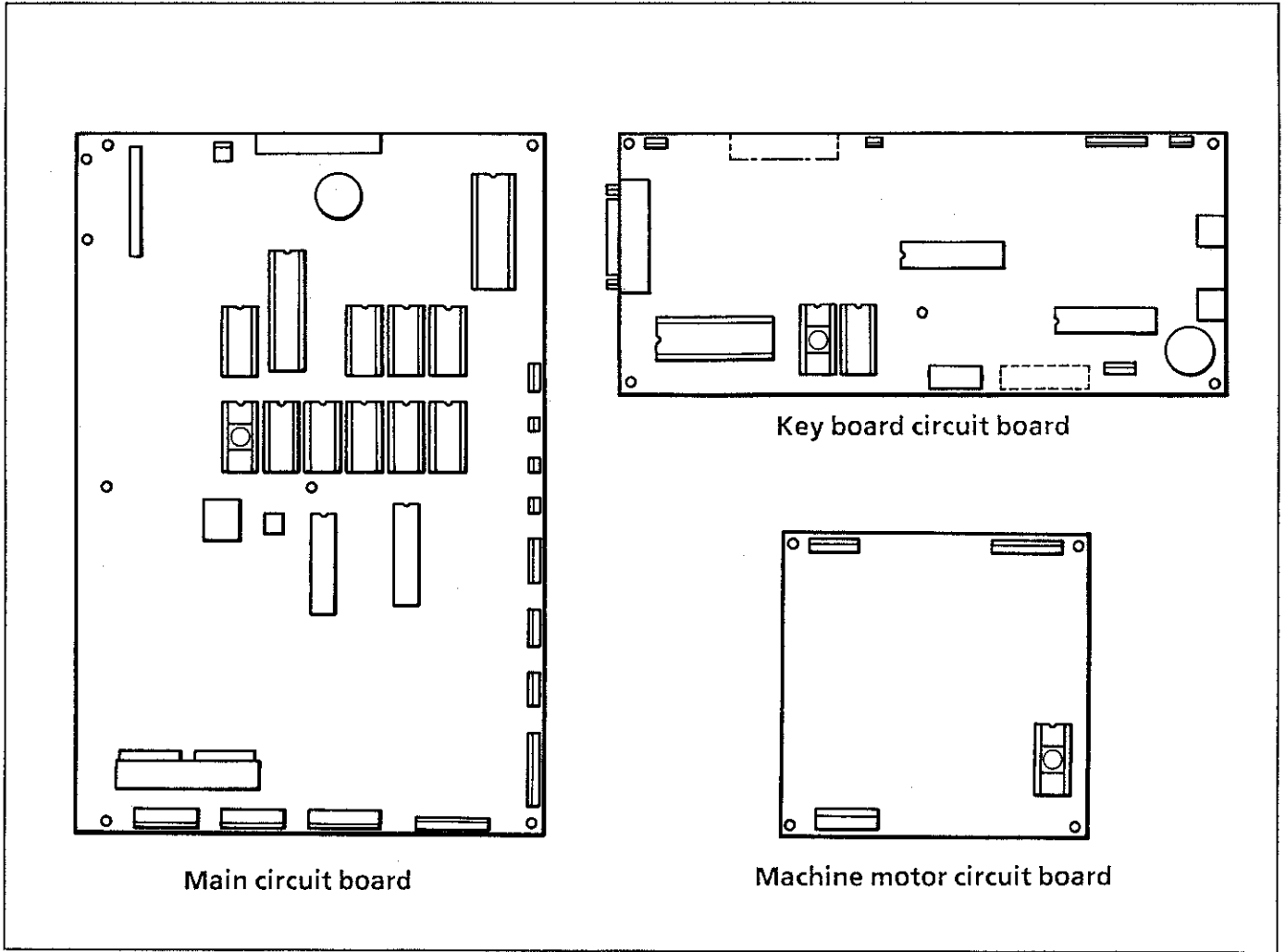

Be sure to turn off the power before replacement.

NOTE1: Pay special attention to P-ROMs.

Check that the pins are properly inserted into sockets.

NOTE2: In attachment, do not treat circuit boards roughly.

NOTE3: Check that P-ROMs are properly positioned.

NOTE4: In replacement, use P-ROM exchanging tool if possible.

When using screw drivers or similar tools, be careful not to break the P-ROM sockets.

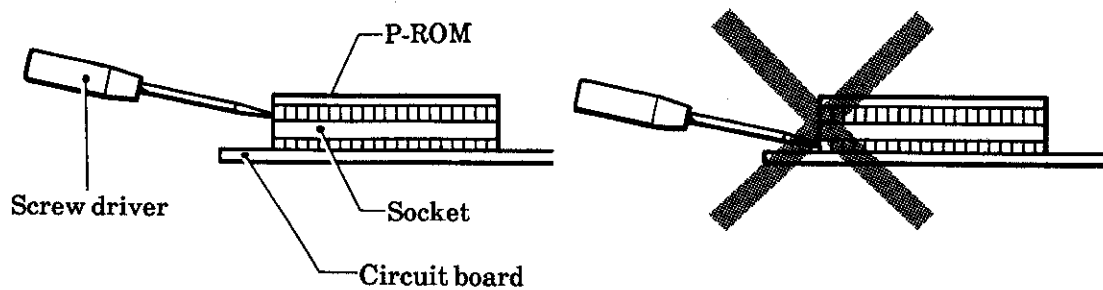

## 5 Explanation of DIP switches

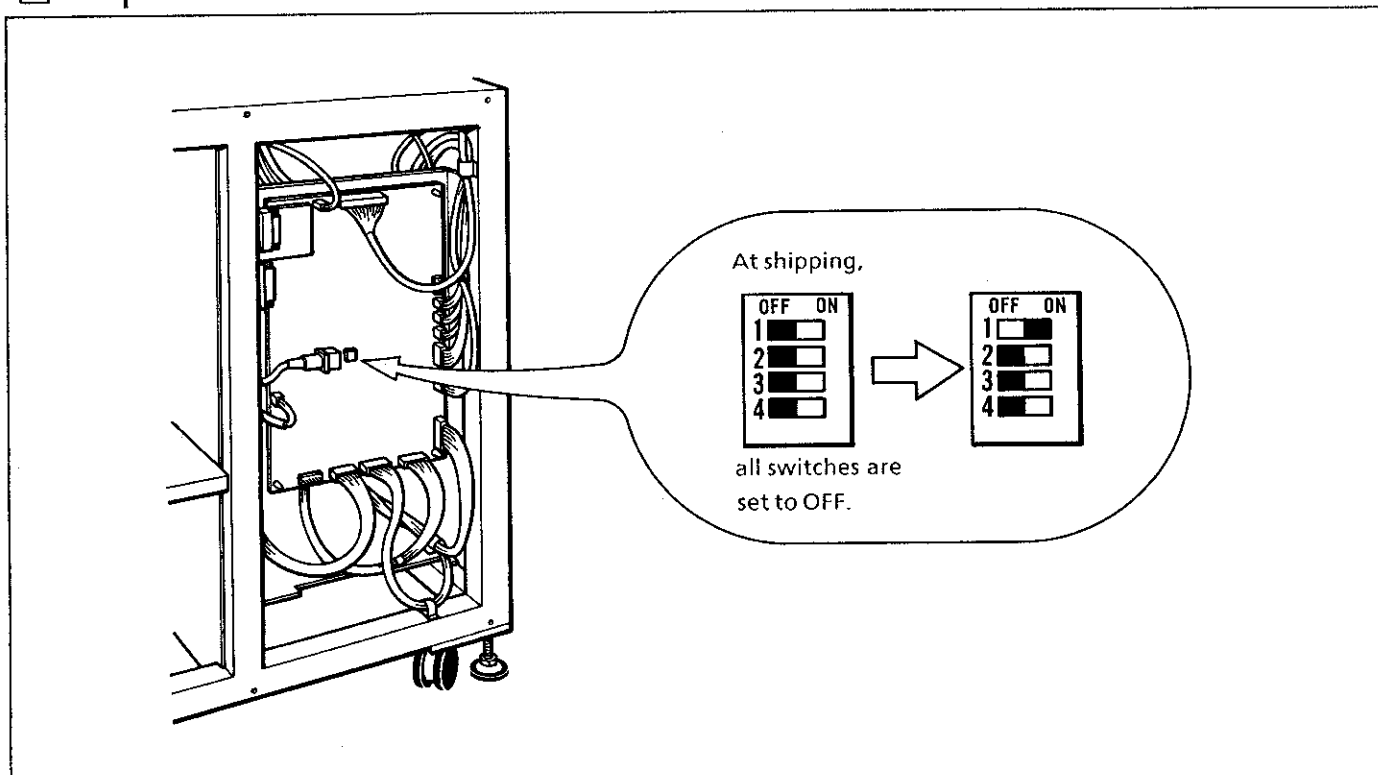

### 1. SW1 ··· Use this key to choose between mm and inch unit system.

At shipping, DIP SW 1 is set to OFF. By switching the DIP switch on, the total length of a pattern or the set sewing area can be specified in inches.

#### Display in inches

##### Example1 Area

ARA : V 10.00 mm H 15.00 mm

This indicates that the vertical length is 10.10 inches (= 257mm) and the horizontal length is 15.30 inches (389mm).

##### Example2 Total length

LG : V 10.00 mm H 15.00 mm

When setting the total length :  
the data is in 4 digits, the minimum unit being 0.01inches.

##### Example3 To set and confirm hoop feed point

HOP: X 10.00 mm Y 15.00 mm

**Example entry**

When setting the vertical length for 3.5 inches and the horizontal length for 10 inches:

Vertical 

|   |   |   |   |
|---|---|---|---|
| 0 | 3 | 5 | 0 |
|---|---|---|---|

Press numeric keys 

|   |    |    |   |
|---|----|----|---|
| 0 | 3  | 5  | 0 |
|   | F3 | F5 |   |

Horizontal 

|   |   |   |   |
|---|---|---|---|
| 1 | 0 | 0 | 0 |
|---|---|---|---|

Press numeric keys 

|    |   |   |   |
|----|---|---|---|
| 1  | 0 | 0 | 0 |
| F1 |   |   |   |

Enter digits in order from left to right.

NOTE: In using inches, errors within 0.254mm should be tolerated, for the minimum unit is 0.001inches.  
In using millimeters, errors within 1mm should be tolerated, for the minimum unit is 1mm.

2. SW2 ..... Mode switching can be changed by PATTERN key in entry mode using DIP switch 2.

- SW2 = ON  
Pattern mode is displayed first.

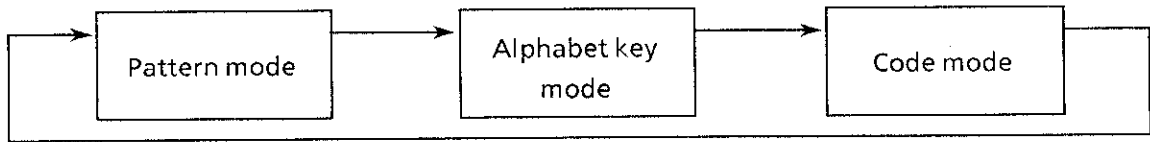

- SW2 = OFF  
Alphabet mode is displayed first.

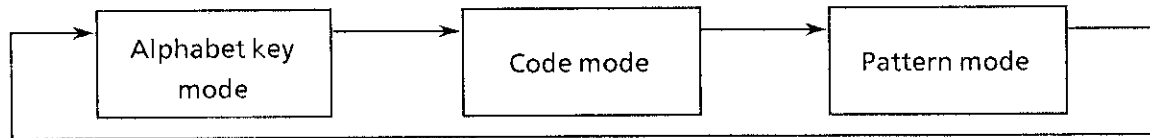

3. SW3 ..... The sewing start point of the embroidery can be changed by switching DIP switch 3

- When the DIP switch 3 is ON  
When the entered data is one pattern, the needle location will be the sewing start point.  
In this case, the area check and the test feed function are not available.  
In entry mode or when the entered data is two patterns or more, the sewing start point will be the same as when the SW3 is OFF.
- SW3 = OFF  
The sewing start point is selected by the centering function.

4. SW4 ..... Not available (should be set to OFF)

## OPTIONAL PARTS

### 1 Small lamp for machine

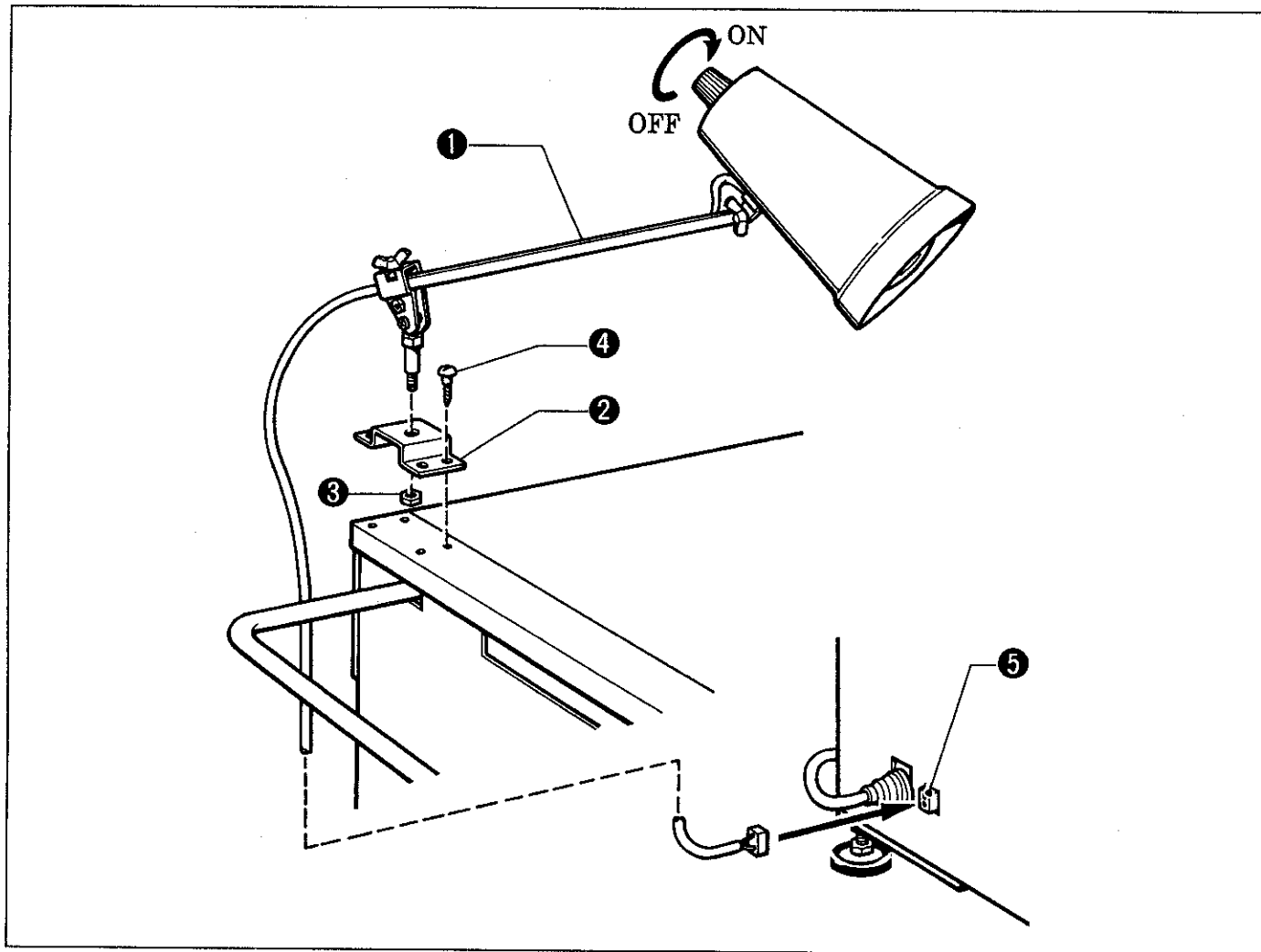

- 1) Turn off the power of the sewing machine.
- 2) With the nut ③, attach the metal fittings ② to the ML651 lamp set assembly ①.
- 3) Attach the lamp set to the table with the 4 screws so that it does not interfere with table movement.
- 4) Plug the cable into the connector ⑤.
- 5) Turn on the power of the machine and the lamp.

NOTE: The lamp connector ⑤ takes only the ML 651 lamp set assembly (S15378-001). Be sure to use the 6.3V17W lamp (alternating current). Using a lamp other than the specified type will result in damage to the lamp.



**BROTHER INDUSTRIES, LTD.**

HEAD OFFICE: No. 35, 9-CHOME,  
HORITA-DORI, MIZUHO-KU, NAGOYA, JAPAN 467  
CABLE: BROTHER NAGOYA,  
TELEX: BROTHER 4473696J & J59743

Printed in Japan 199004 I0040424K