

# **PARTS BOOK**

FOR

## **BROTHER LT2-B833**

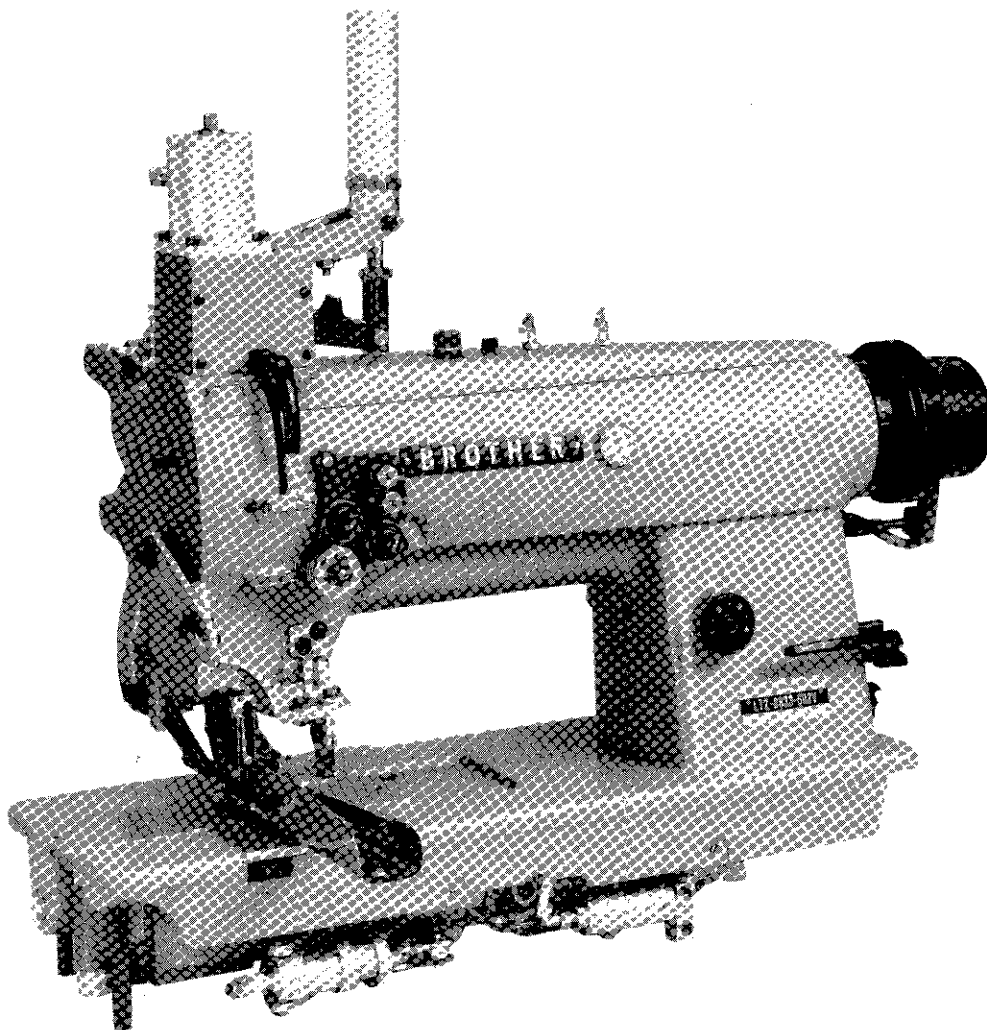



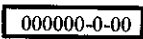
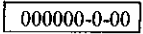
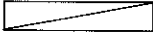

**SEMI-AUTOMATIC POCKET WELTING MACHINE**

**BROTHER INDUSTRIES, LTD.**  
**NAGOYA, JAPAN**

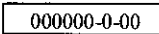

## Notes for using this parts book

1. This book is applicable to sewing machines which have the same plate number as shown on the cover of this book (or correction sheet).
2. If the symbol  or  is in the "Parts No." column or the "Assembly No." column, please refer to the separate parts list (page 16) also,  means the Parts No. for Model 600V.
3. The symbol  in the "Parts No." column indicates that the parts is not available for supply. If, however, there is a number in the "Assembly No." column, the parts can be ordered as an assembly. Please, therefore, order by using the Assembly number.
4. This book was prepared based on information available in May, 1981.
5. Parts are subject to changes in design without prior notice.

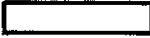
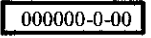
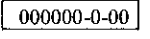

## Anmerkungen zum Gebrauch dieses Stücklistebuches

1. Dieses Buch bezieht sich auf die Nähmaschinen mit derselben Kennungsnummer wie auf diesem Buchumschlag (oder auf dem Korrekturblatt).
2. Wenn in der Stücknummer oder Gerätesatznummer Spalte das Zeichen  oder  steht, schlagen Sie bitte bei der gesonderte Stückliste (Seite 16) nach und nodr dazu gibt  Zeichen für Gerätesatznummer von Model 600V.
3. Dieses Zeichen  in der Spalte "Teilnummer" bedeutet, daß dieser Teil nicht lieferbar ist. Wenn jedoch in der Spalte "Gerätesatznummer" eine Nummer steht, kann dieser Teil als ein Geräteteilsatz bestellt werden. Bestellen Sie daher bitte mit dieser Gerätesatznummer.
4. Dieses Buch basiert auf den Informationen vom Mai, 1981.
5. Modelländerungen sind vorbehalten.

## Notes sur l'utilisation de ce manuel de pièces détachées

1. Ce manuel est destiné aux machines à coudre ayant le même numéro de plaque montré sur la couverture de ce manuel (ou sur la feuille de corrections).
2. Si le symbole  ou  est présent dans la colonne "N° de pièce" ou dans la colonne "N° de ensemble", se référer à la liste de pièces annexe (page 16). Et  indique le numéro de pièce pour Modèle 600V.
3. Le symbole  dans la colonne "N° de pièce" signifie que la pièce ne peut être fournie. Si, dans la colonne "N° jeu de pcs", il y a un numéro de nomenclature, la pièce peut être commandée comme faisant partie d'un jeu de pièces. Donc, pour toute commande, veuillez spécifier le n° du jeu de pièces.
4. Ce manuel a été fait d'après les renseignements valables au mois de Mai, 1981.
5. Les pièces peuvent être sujettes à des modifications sans préavis.

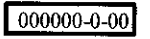
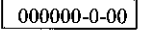
## Notas para usar este Libro de Piezas

1. Este libro sirve para todas las máquinas de coser que llevan la misma placa de identificación que la que se puede ver en la tapa de este libro (o en la hoja de arratas).
2. De haber un símbolo  o el  en la "Número de Pieza" o en la columna del "Número de Juego", habrá que ver la lista de piezas separada (página 16) también,  significa el Nro. de repuestos modelo 600V.
3. El símbolo , que se encuentra en la columna del "Número de Pieza", quiere decir que no se dispone de dicha pieza sola. Cuando, empero, hay un número en la columna del "Número de Juego", se podrá ordenar la pieza con todo el juego. Por lo tanto, será mejor hacer el pedido recurriendo al número del juego respectivo.
4. Este libro ha sido compilado basándose en los datos de que se disponía en Mayo, 1981.
5. Las piezas quedan sujetas a cambios de diseño sin aviso previo.

## CONTENTS

A.	Machine Body and Threading .....	1
B.	Upper Shaft · Needle Bar and Rocking Mechanism .....	2
C.	Presser Foot and Reverse Mechanism .....	3
D.	Feed Mechanism .....	4
E.	Lower Shaft · Rotary Hook Mechanism .....	5
F.	Thread Trimmer Mechanism .....	6
G.	Tension Release Mechanism .....	7
H.	Knife Mechanism .....	8
J.	Corner Cutter Mechanism (Model 600V) .....	9
K.	Lubrication .....	10
L.	Synchronizer Mechanism .....	11
M.	Valve Box Mechanism .....	12
N.	Lupper Mechanism .....	13
Z.	Accessories .....	14
a.	GAUGE PARTS LIST .....	15
	DIFFERENT PARTS LIST .....	16
	INDEX .....	17

# A. Machine Body and Threading

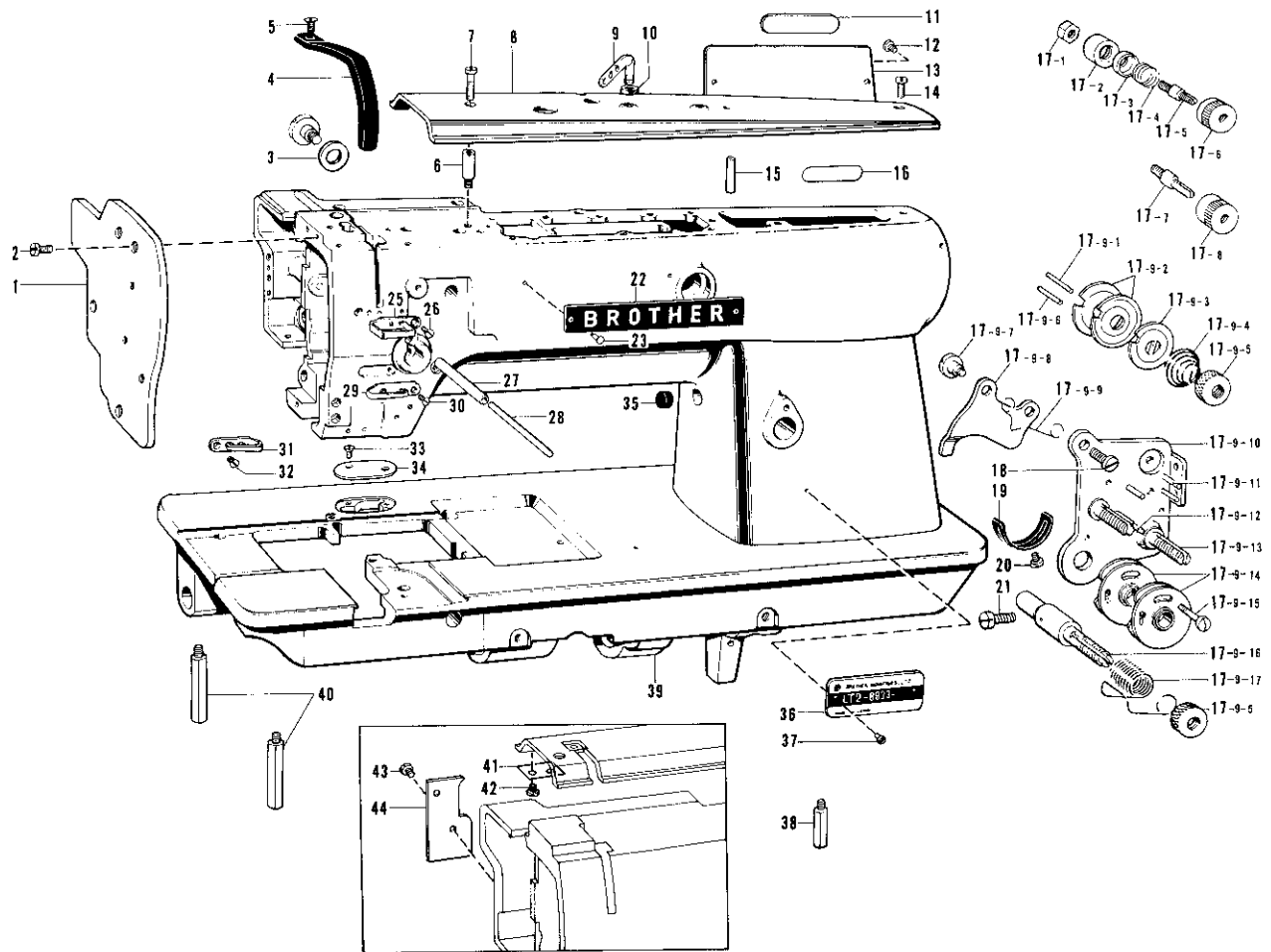

Ref. No.	Name of Parts	Q'ty	Parts No.	Assembly No.	Ref. No.	Name of Parts	Q'ty	Parts No.	Assembly No.
A-1	Face Plate	1	155873-0-01		A-17-9-11	Pin	3		A-17-9 Tension Control Plate Assembly 181756-0-01
A-2	Screw 3.57 x 8	4	009670-8-12		A-17-9-12	Pin	2		
A-3	Collar	1	148605-0-01		A-17-9-13	Tension Stud	2		
A-4	Thread Take-up Cover	1	156058-0-01		A-17-9-14	Spring Guide	2	108254-0-01	
A-5	Screw 4.76	1	107231-0-02		A-17-9-15	Set Screw 2.38	1	144682-0-01	
A-6	Stud (B)	1	147856-0-01		A-17-9-16	Tension Stud	1	144680-0-01	
A-7	Screw 4.37 x 8	1	009680-8-13		A-17-9-17	Thread Take-up Spring	1	144681-0-01	
A-8	Arm Top Cover	1	155872-0-01		A-18	Screw 4.37 x 10	1	009681-0-14	
A-9	Top Cover Thread Guide	2	140527-0-01		A-19	Stopper	1	112709-0-01	
A-10	Nut 5.95	2	150553-0-03		A-20	Screw 3.57 x 6	1	009670-6-12	
A-11	Name Plate	1			A-21	Screw 3.57	1	100064-0-02	
A-12	Screw 3.57 x 6	2	009670-6-12		A-22	Name Plate	1		
A-13	Rear Cover	1	112566-0-03		A-23	Pin	2		
A-14	Screw 4.37 x 10	1	009681-0-13		A-25	Arm Thread Guide Upper	1	108266-0-01	
A-15	Pipe	1	112696-0-00		A-26	Screw 3.57	1	108960-0-04	
A-16	Parts Book Number Plate	1			A-27	Tension Release Pipe	1	148604-0-00	
A-17-1	Nut 3.57	2	021670-1-02	A-17 Upper Tension Control Assembly 148805-0-01	A-28	Tension Release Bar	1	112713-0-01	
A-17-2	Thread Guide Bracket	2	148666-0-01		A-29	Arm Thread Guide, Center	1	112658-0-01	
A-17-3	Thread Disc	2	148667-0-01		A-30	Screw 3.57	1	108960-0-04	
A-17-4	Thread Guide Spring	2	148668-0-01		A-31	Arm Thread Guide, Center	1	112658-0-01	
A-17-5	Thread Guide Screw A	1	148662-0-01		A-32	Screw 3.57	1	108960-0-04	
A-17-6	Thread Guide Screw A	1	148664-0-01		A-33	Screw 3.18	2	149288-0-01	
A-17-7	Thread Guide Screw B	1	148663-0-01		A-34	Cover	1	148614-0-01	
A-17-8	Thread Guide Screw B	1	148665-0-01		A-35	Cap	1	143766-0-01	
A-17-9-1	Pin	1	148670-0-01		A-36	Model Plate B833	1		
A-17-9-2	Tension Disc	4	108263-0-01		A-37	Pin	2		
A-17-9-3	Tension Disc Washer	2	148669-0-01	A-38	Bed Leg Small	1	149179-0-01		
A-17-9-4	Tension Spring	2	118317-0-01	A-39	Arm Bed	1			
A-17-9-5	Tension Control Nut	3	108265-0-01	A-40	Bed Leg	2	148611-0-01		
A-17-9-6	Pin	1	148671-0-01	A-41	Arm Top Sub-cover	1			
A-17-9-7	Stud Screw 3.57	2	112712-0-01	A-42	Screw 3.18 x 4	2			
A-17-9-8	Tension Release Plate	1	144683-0-01	A-43	Screw 3.57 x 6	2			
A-17-9-9	Arm Thread Guide Upper	1	118320-0-01	A-44	Bracket Cover	1			
A-17-9-10	Thread Tension Plate	1							

## B. Upper Shaft · Needle Bar and Rocking Mechanism

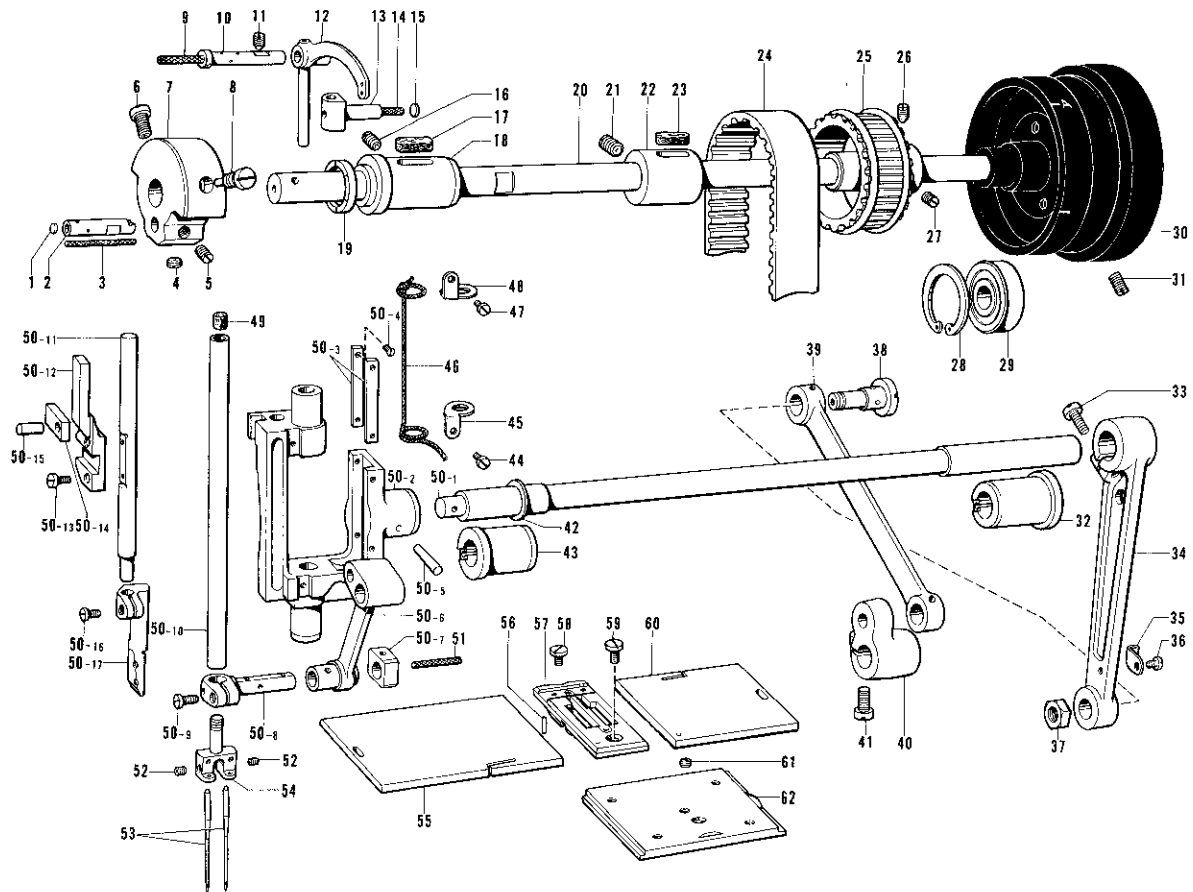

Ref. No.	Name of Parts	Q'ty	Parts No.	Assembly No.	Ref. No.	Name of Parts	Q'ty	Parts No.	Assembly No.
B- 1	Pusher	1	113014-0-00		B-40	Needle Bar Connecting Crank	1	112598-0-01	
B- 2	Needle Bar Crank	1	112577-0-01		B-41	Screw 6.35 x 18	1	009781-8-12	
B- 3	wick	1	112735-0-00		B-42	Spacer	1	155879-0-01	
B- 4	Screw 6.35	1	101706-0-01		B-43	Needle Bar Rock Shaft Bushing Left	1	112594-0-01	
B- 5	Screw 6.35	1	100251-0-01		B-44	Screw	1	009660-4-12	
B- 6	Screw 7.14	1	146141-0-01		B-45	Wick Supporter (D)	1	143675-0-01	
B- 7	Counter Weight	1	112574-0-00		B-46	Wick 300 mm	1	116699-0-00	
B- 8	Screw 7.14	1	100250-0-01		B-47	Screw 3.18 x 4	1	009660-4-12	
B- 9	Wick 12 mm	1	112735-0-01		B-48	Wick Supporter (U)	1	143674-0-01	
B-10	Stud	1	112579-0-01		B-49	Cap	1	148394-0-00	
B-11	Screw 5.95	1	151605-0-01		B-50- 1	Needle Bar Rock Shaft	1		
B-12	Thread Take-up Lever	1	112578-0-01		B-50- 2	Needle Bar Support	1	153008-0-01	
B-13	Thread Take-up Lever Slide Block	1	118171-0-01		B-50- 3	Guide Plate	2		
B-14	Wick	1	114693-0-01		B-50- 4	Screw 2.37	4	102731-0-04	
B-15	Pusher	1	113024-0-00		B-50- 5	Pin	1	107030-0-01	
B-16	Screw 5.95	1	013761-4-10		B-50- 6	Needle Bar Crank Rod	1	112593-0-01	
B-17	Felt	1	112734-0-01		B-50- 7	Needle Bar Guide Slide Block	1	112721-0-01	
B-18	Upper Shaft Bushing Left	1	112573-0-01		B-50- 8	Needle Bar Clamp	1	143581-0-01	
B-19	Thrust Ring	1	112576-0-01		B-50- 9	Screw 3.57 x 8	1	009670-8-12	
B-20	Upper Shaft	1	143576-0-01		B-50-10	Needle Bar	1	153009-0-01	
B-21	Screw	1	013761-4-10		B-50-11	Cutter Bar	1	153013-0-01	
B-22	Upper Shaft Bushing Center	1	114680-0-01		B-50-12	Cutter Bar Guide	1	143645-0-01	
B-23	Felt	1	100248-0-01		B-50-13	Screw 3.57 x 8	2	009670-8-12	
B-24	Timing Belt	1	112586-0-01		B-50-14	Cutter Bar Guide Block	1		
B-25	Timing Belt Wheel Upper Assembly	1	180157-0-01		B-50-15	Stud 5.5 x 11	1	143637-0-01	
B-26	Screw 6.35 x 12	1	015771-2-12		B-50-16	Screw 3.57 x 7	1	009670-7-12	
B-27	Screw 6.35 x 12	1	013771-2-12		B-50-17	Cutter Holder Bar	1	155878-0-01	
B-28	Stop Ring	1	112760-0-01		B-51	Wick	1	112728-0-01	
B-29	Bearing 6204 VV.	1	072620-4-60		B-52	Screw 3.18	2	146427-0-01	
B-30	Pulley	1	154506-0-01		B-53	Needle MT x 190	2	153011-0-16	
B-31	Screw	2	013761-4-10		B-54	Needle Clamp 10	1	153021-0-01	
B-32	Needle Bar Rock Shaft Bushing Right	1	112764-0-01		B-55	Slide Plate, Left	1	112606-0-01	
B-33	Screw 6.35	1	105351-0-02		B-56	Pin	1	113386-0-00	
B-34	Needle Bar Connecting Rod	1	112595-0-00		B-57	Needle Plate Assembly	1	155935-0-01	
B-35	Wick Supporter	1	112739-0-01		B-58	Set Screw 3.57	1	112751-0-02	
B-36	Set Screw 3.57	1	009670-5-12		B-59	Screw 4.37	1	105955-0-01	
B-37	Nut 7.94	2	101268-0-03		B-60	Slide Plate, Right	1	112607-0-01	
B-38	Needle Bar Rock Link Stud	2	112597-0-01		B-61	Screw 5.16	1	116010-0-01	
B-39	Needle Bar Rock Link	1	112596-0-01		B-62	Slide Plate	1	148599-0-01	

B-50  
Needle Bar  
Rock Shaft  
Assembly  
155877-0-01

## C. Presser Food and Reverse Mechanism

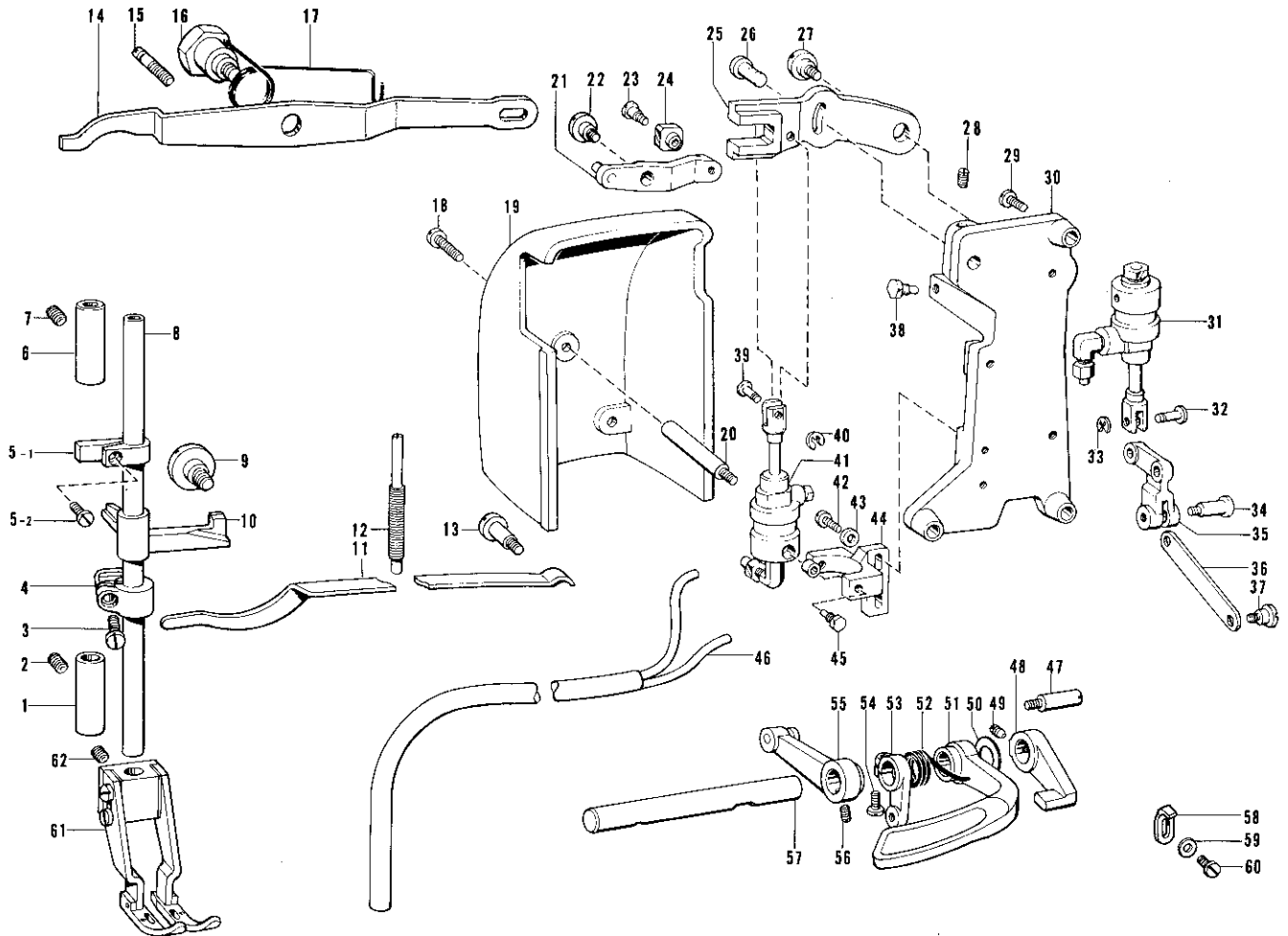

Ref. No.	Name of Parts	Q'ty	Parts No.	Assembly No.	Ref. No.	Name of Parts	Q'ty	Parts No.	Assembly No.
C-1	Presser Bar Bushing, Lower	1	112763-0-01		C-31	Reverse Cylinder	1	149031-0-01	
C-2	Screw 5.95	1	151604-0-01		C-32	Pin	1	146153-0-01	
C-3	Screw 4.37 x 12	1	009681-2-14		C-33	Stop Ring E-4	1	048040-3-42	
C-4	Presser Bar Bracket	1	155881-0-01		C-34	Stud Screw 4.76	2	148764-0-01	
C-5-1	Presser Bar Guide	1		C-5 Presser Bar Guide Assembly 148835-0-01	C-35	Reverse Link Lever	1	149033-0-01	
C-5-2	Set Screw 4.37 x 7	1	009680-7-12		C-36	Reverse Link	1	149063-0-01	
C-6	Presser Bar Bushing, Upper	1	112615-0-01		C-37	Stud Screw 4.76	1	110171-0-01	
C-7	Set Screw 5.95	1	100260-0-01		C-38	Screw	2	140620-0-01	
C-8	Presser Bar	1	155880-0-01	C-39	Pin	1	146153-0-01		
C-9	Presser Bar Lifter Guide	1	112631-0-01	C-40	Stop Ring E-4	1	048040-3-42		
C-10	Presser Bar Lifter	1	155882-0-01	C-41	Presser Foot Lifter Cylinder	1	149019-0-01		
C-11	Presser Plate Spring	1	118170-1-01	C-42	Screw 4.76 x 16	2	009711-6-12		
C-12	Presser Adjusting Screw	1	112624-0-01	C-43	Washer 4.76	2	025710-2-32		
C-13	Stud Screw 6.35	1	112623-0-01	C-44	Cylinder Supporter	1	149023-0-01		
C-14	Knee Lifter Lever	1	156015-0-01	C-45	Screw	2	140620-0-01		
C-15	Stopper Screw	1	112630-0-01	C-46	Air Tube Assembly	1	155883-0-01		
C-16	Stud Screw 6.35	1	112626-0-01	C-47	Screw	1	141748-0-01		
C-17	Knee Lifter Lever Spring	1	149768-0-01	C-48	Preverse Lever (B)	1	148607-0-02		
C-18	Screw 4.76 x 12	2	009711-2-12	C-49	Screw 6.35 x 10	1	015771-0-12		
C-19	Cylinder Cover	1	149035-0-02	C-50	Thrust Ring	1	149554-0-01		
C-20	Cylinder Cover Stud	2	149034-0-01	C-51	Preverse Lever	1	148606-0-03		
C-21	Lever Assembly	1	149027-0-01	C-52	Spring	1	148608-0-01		
C-22	Screw 6.35	1	149991-0-01	C-53	Reverse Lever Shaft Arm	1	148640-0-01		
C-23	Screw	1	141494-0-01	C-54	Screw 4.76 x 14	1	009711-4-12		
C-24	Slide Block Assembly	1	149025-0-01	C-55	Feed Regulator Link	1	148638-0-01		
C-25	Presser Foot Lifter Lever	1	149024-0-01	C-56	Screw 5.95 x 6	1	014760-6-22		
C-26	Pin	1	118713-0-01	C-57	Reverse Lever Shaft	1	148609-0-01		
C-27	Stud Screw 6.35	1	141439-0-01	C-58	Reverse Lever Stopper	1	149282-0-01		
C-28	Set Screw 4.76	1	013710-7-12	C-59	Washer	1	100645-0-03		
C-29	Screw 6.35 x 14	3	009782-5-12	C-60	Screw 4.37 x 10	1	009681-0-12		
C-30	Cylinder Base	1	149030-0-01	C-61	Presser Foot Assembly 10	1	155937-0-01		
				C-62	Screw 4.37 x 4	1	014680-4-22		

# D. Feed Mechanism

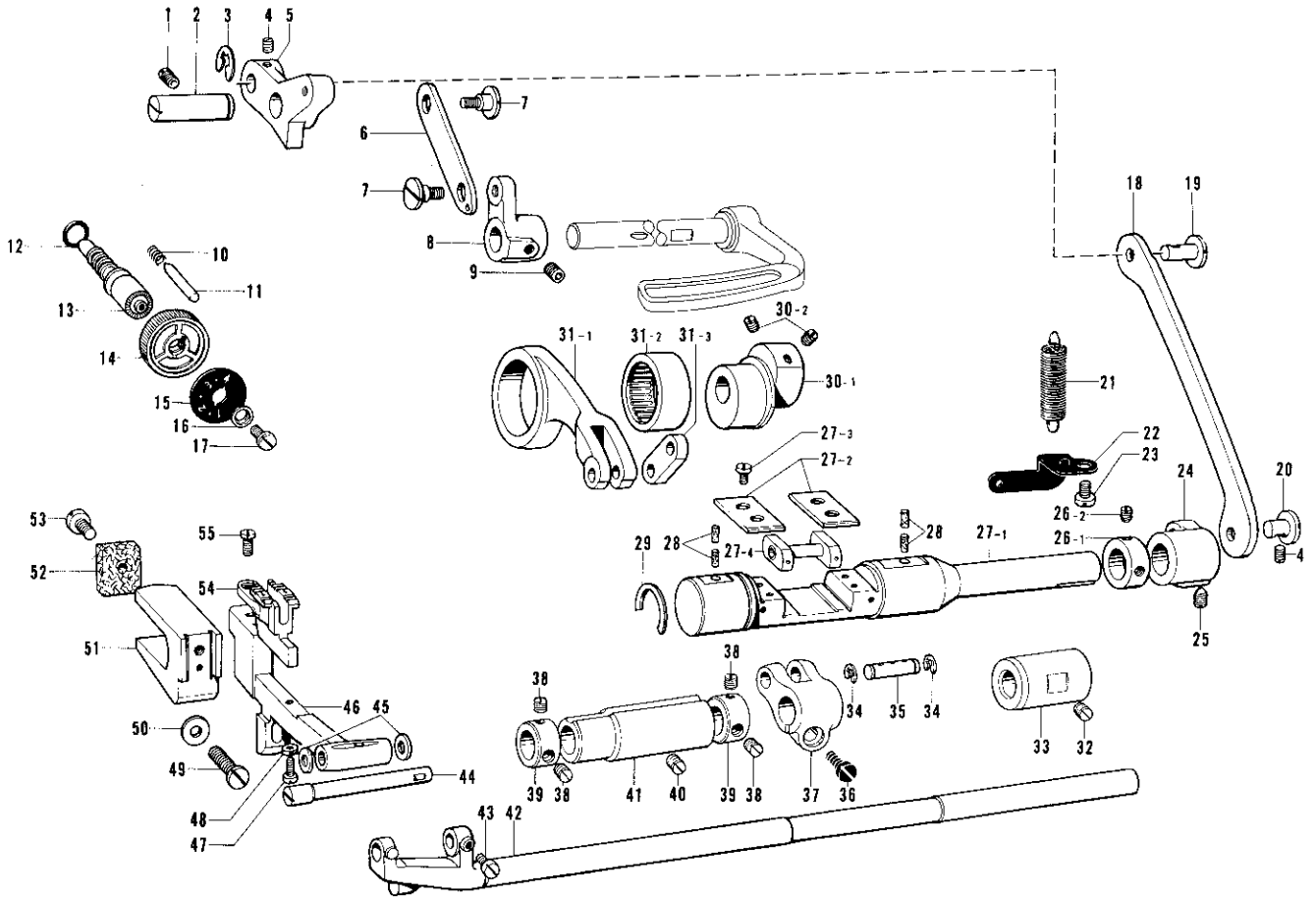

Ref. No.	Name of Parts	Q'ty	Parts No.	Assembly No.	Ref. No.	Name of Parts	Q'ty	Parts No.	Assembly No.
D-1	Screw 5.95	1	151605-0-01		D-29	Stop Ring	1	143597-0-01	
D-2	Feed Regulator Stud	1	148488-0-01		D-30-1	Eccentric Wheel	1		D-30 Eccentric Wheel with Screw 148802-0-01
D-3	Stop Ring E-7	1	048070-3-42		D-30-2	Screw 5.95	2	151605-0-01	
D-4	Screw 4.37	2	151602-0-01		D-31-1	Level Feed Connecting Rod	1	148496-0-00	D-31 Feed Connecting Rod Assembly 148801-0-01
D-5	Feed Regulator Stud	1	148489-0-01		D-31-2	Needle Bearing	1	118954-0-00	
D-6	Connecting Plate	1	118746-0-01		D-31-3	Level Feed Connecting Link	1	143613-0-01	
D-7	Stud Screw 4.37	2	112072-0-01		D-32	Screw 5.95	1	013761-4-10	
D-8	Feed Regulator Bracket	1	118747-0-01		D-33	Feed Rock Shaft Bushing Right	1	148493-0-01	
D-9	Screw 5.95	1	118853-0-01		D-34	Stop Ring E-6	2	048060-3-42	
D-10	Notch Spring	1	100328-0-01		D-35	Stud	1	143616-0-01	
D-11	Pin	1	145502-0-01		D-36	Screw 6.35 x 18	1	009781-8-12	
D-12	Packing	1	108549-0-01		D-37	Ruffling Plate Lifter Lever Assembly	1	148495-0-01	
D-13	Length Control Screw	1	143598-0-01		D-38	Screw 6.35	4	101706-0-01	
D-14	Length Control Dial	1	153168-0-01		D-39	Feed Rock Shaft Collar	2	113074-0-01	
D-15	Feed Regulator Plate	1	151508-0-01		D-40	Screw 5.95	1	013761-4-10	
D-16	Length Control Supporter	1	142746-0-02		D-41	Feed Rock Shaft Bushing Left	1	148494-0-01	
D-17	Set Screw 4.76	1	142747-0-02		D-42	Feed Rock Shaft	1	148492-0-01	
D-18	Feed Regulator Connecting Link	1	148487-0-01		D-43	Screw 4.37	1	104908-0-04	
D-19	Pin	1	118713-0-01		D-44	Feed Bar Shaft	1	148491-0-01	
D-20	Pin	1	148501-0-01		D-45	Thrust Ring	2	143591-0-01	
D-21	Spring	1	143609-0-01		D-46	Feed Bar	1	148490-0-01	
D-22	Spring Hook Plate	1	143610-0-01		D-47	Screw 3.18	1	107278-0-02	
D-23	Screw 4.37 x 8	1	009710-8-12		D-48	Nut 3.18	1	021660-1-03	
D-24	Feed Regulator Shaft Arm	1	148499-0-01		D-49	Screw 5.95 x 14	1	009761-4-12	
D-25	Screw 5.95	1	118853-0-01		D-50	Washer 6	1	025060-1-32	
D-26-1	Collar	1		D-26 Collar Assembly 180321-0-01	D-51	Feed Bar Fork	1	112656-0-01	
D-26-2	Screw 6.35	2	101706-0-01		D-52	Felt	1	112759-0-01	
D-27-1	Feed Regulator Shaft	1		D-27 Feed Regulator Shaft Assembly 148771-0-01	D-53	Screw 3.57	1	100242-0-03	
D-27-2	Guide Plate	2			D-54	Feed Dog 10	1	155946-0-01	
D-27-3	Screw 4.37 x 10	4	009681-0-12		D-55	Screw 3.18	2	116283-0-01	
D-27-4	Slide Block	1							
D-28	Felt	4	148743-0-01						

# E. Lower Shaft · Rotary Hook Mechanism

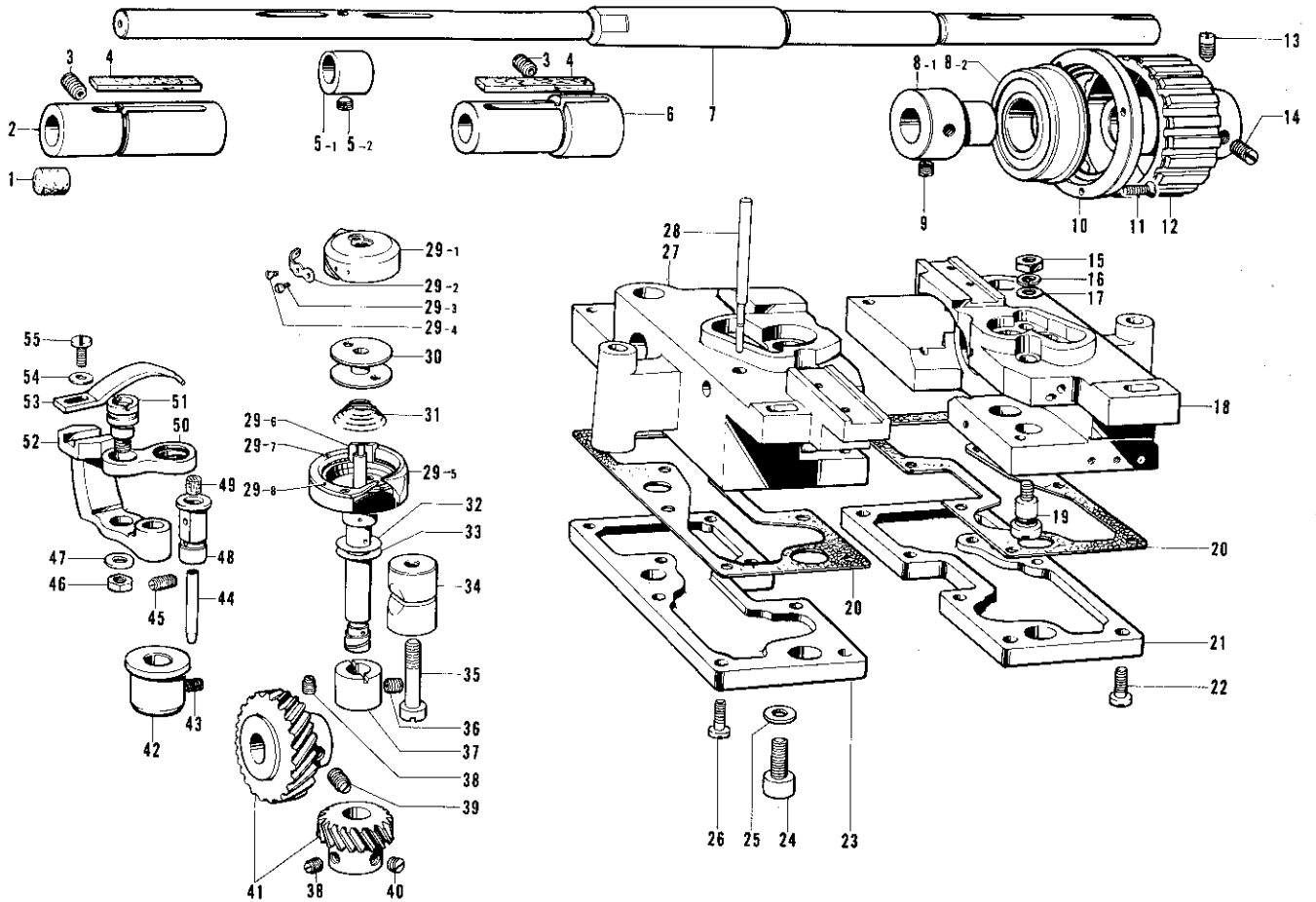

Ref. No.	Name of Parts	Q'ty	Parts No.	Assembly No.	Ref. No.	Name of Parts	Q'ty	Parts No.	Assembly No.
E-1	Felt	1	115249-0-01		E-29-2	Adjusting Spring	2	154518-0-01	
E-2	Rotary Hook Base Bushing Left	1	148503-0-00		E-29-3	Screw	2	154520-0-01	
E-3	Screw 5.95	2	151604-0-01		E-29-4	Adjusting Screw	2	154519-0-01	
E-4	Felt (Right)	2	113362-0-01		E-29-5	Outer Rotary Hook Assembly	2		E-29 Cap Equipped Rotary Hook (8832-400C) 154524-0-01
E-5-1	Vertical Feed Eccentric	1		E-5 Vertical Feed Eccentric Assembly 148804-0-01	E-29-6	Inner Rotary Hook Assembly	2		
E-5-2	Screw 6.35	1	112684-0-01		E-29-7	Screw	4	151027-0-01	
E-6	Rotary Hook Base Bushing Right	1	148502-0-00	E-29-8	Inner Rotary Hook Presser	2	151021-0-01		
E-7	Lower Shaft	1	148505-0-01		E-30	Bobbin	2	148603-0-01	
E-8-1	Ball Bearing	1	112666-0-00	E-8 Bearing Holder Assembly 112698-0-01	E-31	Spring	2	148602-0-01	
E-8-2	Bushing	1	112667-0-01		E-32	Spacer 0.2	4	153243-0-01	
E-9	Screw 6.35 x 7	2	013780-7-10		E-33	Spacer 0.3	2	153244-0-01	
E-10	Presser	1	112668-0-01		E-34	Pinch Sleeve	2	112699-0-01	
E-11	Screw 3.57 x 12	3	005671-2-12		E-35	Screw 5.95	2	112700-0-01	
E-12	Timing Belt Wheel Lower Assembly	1	180164-0-01		E-36	Screw 4.76	2	107794-0-01	
E-13	Screw 6.35	1	148821-0-01		E-37	Rotary Hook Shaft Bushing, Upper	2	112690-0-01	
E-14	Screw 6.35 x 12	1	013771-2-12		E-38	Screw 6.35	2	112684-0-01	
E-15	Nut 4.37	2	105234-0-01		E-39	Screw 6.35	4	100251-0-01	
E-16	Washer 2.4.37	2	028680-2-43		E-40	Screw 6.35	6	101706-0-01	
E-17	Washer	2	100645-0-03		E-41	Spiral Gear Assembly	2	180949-0-01	
E-18	Rotary Hook Base Right	1	148480-0-01		E-42	Rotary Hook Shaft Bushing, Lower	2	112687-0-01	
E-19	Oil Adjusting Screw	2	112756-0-01		E-43	Screw 4.76	2	107794-0-01	
E-20	Packing	2	112755-0-01		E-44	Pipe	1	112696-0-00	
E-21	Rotary Hook Base Oil Reservoir, Right	1	112702-0-01		E-45	Screw 4.76	2	153483-0-01	
E-22	Screw 4.76	8	100320-0-02		E-46	Nut 4.76	2	110161-0-06	
E-23	Oil Reservoir, Left	1	112686-0-01		E-47	Washer 4.76	2	025710-2-32	
E-24	Screw 6.35	2	149569-0-01		E-48	Stud Shaft	2	112695-0-01	
E-25	Washer 6.35	2	025770-2-32		E-49	Felt	2	107155-0-01	
E-26	Screw 4.76	8	100320-0-02		E-50	Opener Link	2	112692-0-01	
E-27	Rotary Hook Base Left	1	148481-0-01		E-51	Stud	2	148005-0-01	
E-28	Oil Gauge	2	148728-0-01		E-52	Opener Crank	2	112694-0-01	
E-29-1	Bobbin Case	2	154517-0-01	E-29 154524-0-1	E-53	Bobbin Case Opener	2	112697-0-01	
					E-54	Washer	2	105161-0-02	
					E-55	Screw 3.57 x 8	2	009670-8-12	

# F. Thread Trimmer Mechanism

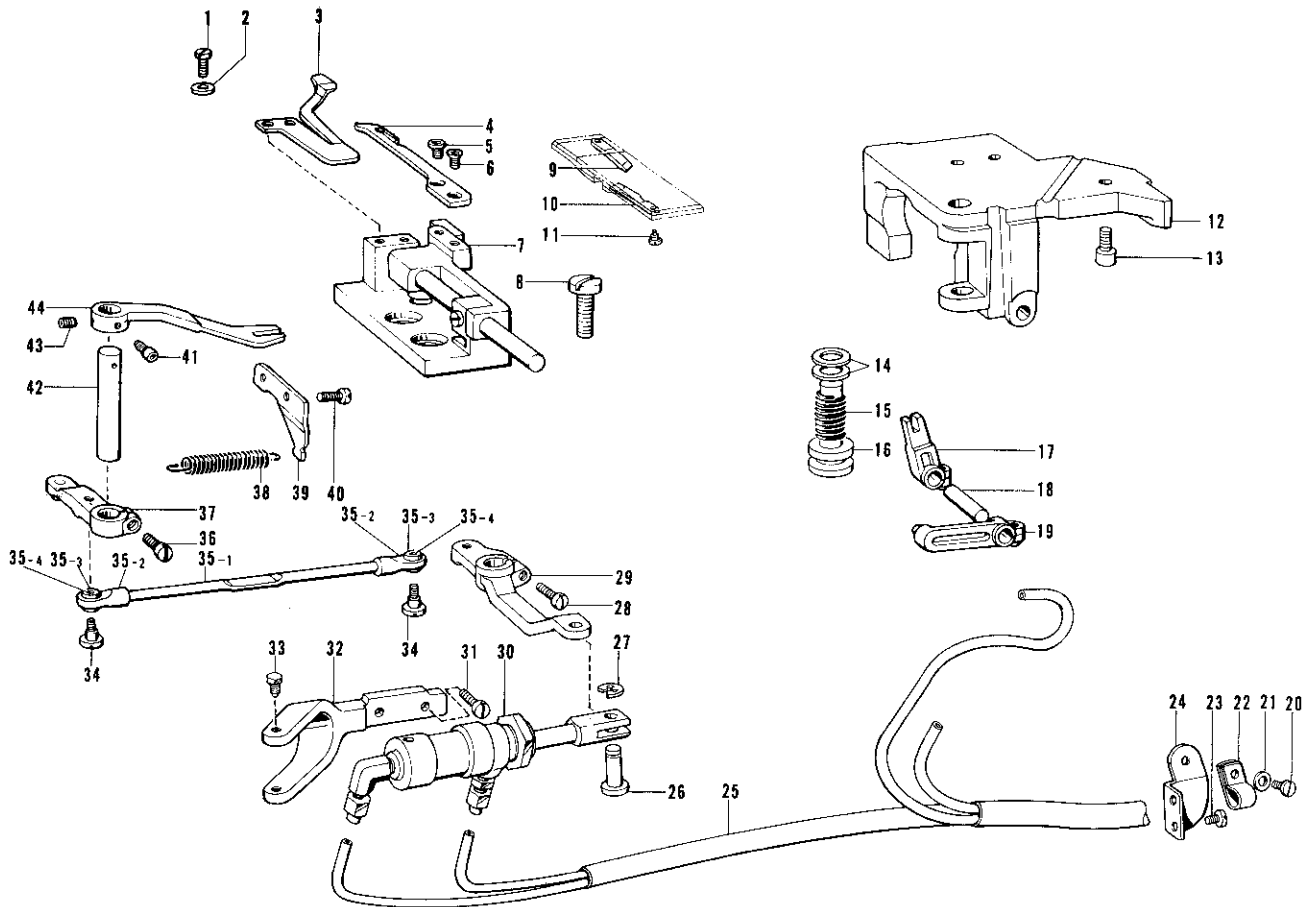

Ref. No.	Name of Parts	Q'ty	Parts No.	Assembly No.	Ref. No.	Name of Parts	Q'ty	Parts No.	Assembly No.
F- 1	Screw 2.38 x 4	4	001630-4-02		F-25	Air Tube Assembly	1	149284-0-01	
F- 2	Washer 2.38	4	025630-1-32		F-26	Pin	1	146153-0-01	
F- 3	Thread Presser Plate	2	148593-0-00		F-27	Stop Ring E-4	1	048040-3-42	
F- 4	Moveable Knife	2	148535-0-01		F-28	Screw 4.76 x 14	1	009711-4-12	
F- 5	Screw 4.37	2	148536-0-01		F-29	Thread Trimming Lever	1	149042-0-01	
F- 6	Screw 4.37	2	148537-0-01		F-30	Thread Trimming Cylinder	1	149037-0-01	
F- 7	Movable Knife Base Assembly	2	148531-0-01		F-31	Screw 4.76 x 16	2	009711-6-12	
F- 8	Screw 4.76 x 8	4	009710-8-12		F-32	Cylinder Supporter	1	149040-0-01	
F- 9	Fixed Knife Right	1	149169-0-01		F-33	Screw	2	140620-0-01	
F-10	Fixed Knife Left	1	148538-0-01		F-34	Screw	2	141494-0-01	
F-11	Stud Screw 2.38	2	148539-0-01		F-35- 1	Knife Connecting Bar	1		
F-12	Movable Knife Base Bracket	1	149036-0-01		F-35- 2	Joint	2		F-35 Knife Connecting Bar Assembly 149697-0-01
F-13	Boit 6 x 16	3	018061-6-22		F-35- 3	Bushing	2	141331-0-01	
F-14	Rubber	2	148559-0-00		F-35- 4	Spring Pin AW2	2	047201-0-42	
F-15	Spring	1	148555-0-01		F-36	Screw 4.76 x 14	1	009711-4-12	
F-16	Knife Main Lever Shaft	1	148547-0-01		F-37	Knife Rock Lever Left	1	148577-0-01	
F-17	Knife Driving	1	181713-0-01		F-38	Spring	1	148571-0-01	
F-18	Knife Driving Lever Shaft 6.35 x 27	1	148557-0-01		F-39	Spring Hook Left	1	148580-0-01	
F-19	Knife Driving Pin Lever	1	181712-0-01		F-40	Screw 4.76 x 10	2	009711-0-12	
F-20	Screw 3.57 x 8	1	009670-8-12		F-41	Screw 6.35 x 6	2	014770-6-22	
F-21	Washer	1	105161-0-02		F-42	Knife Rock Arm Shaft	2	148573-0-01	
F-22	Nylon Clamp	1	149287-0-00		F-43	Screw 6.35	2	148574-0-01	
F-23	Screw 3.57 x 8	2	009670-8-12		F-44	Knife Rock Arm	2	148572-0-01	
F-24	Tube Holder	1	149286-0-01						

# G. Tension Release Mechanism

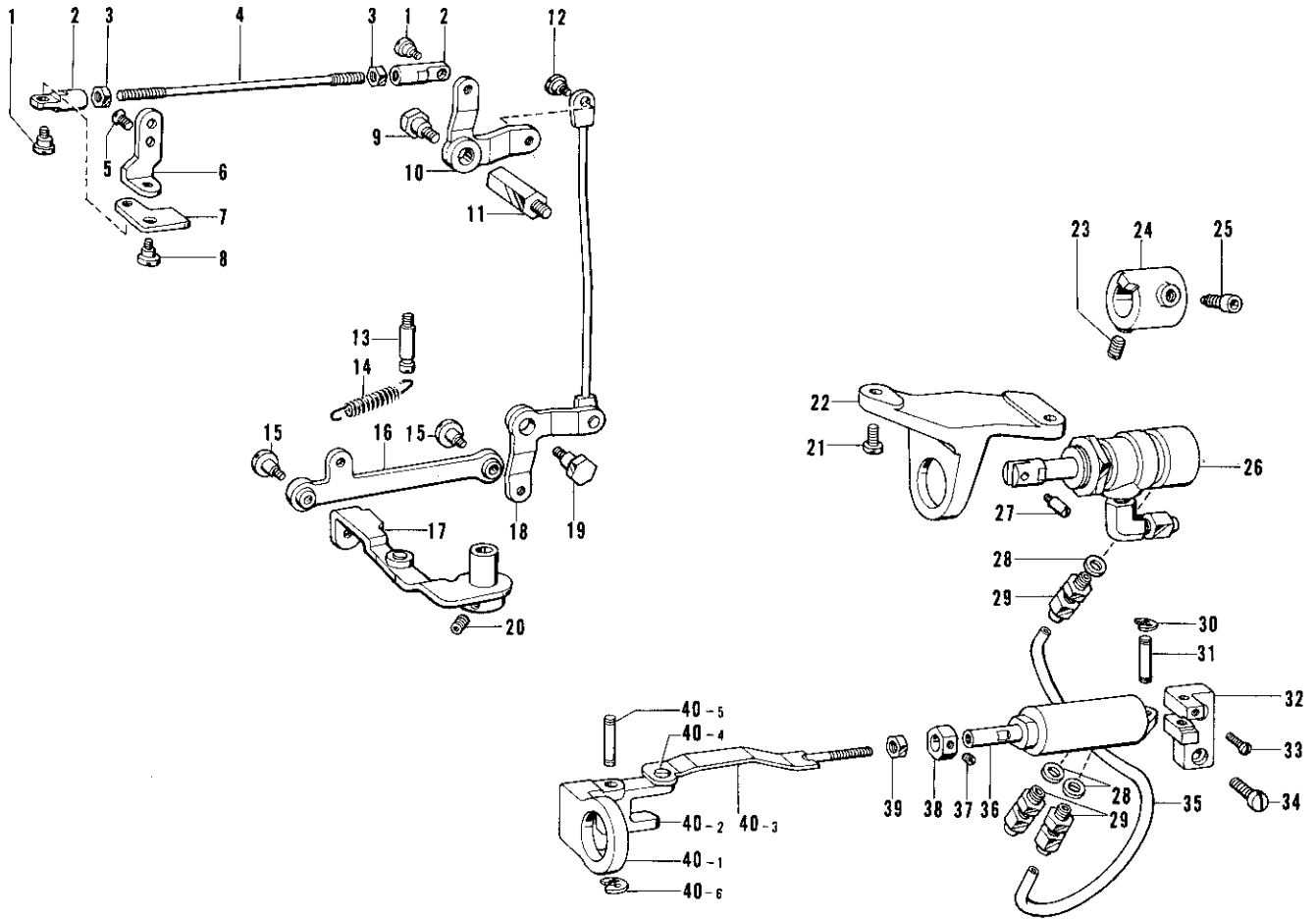

Ref. No.	Name of Parts	Q'ty	Parts No.	Assembly No.	Ref. No.	Name of Parts	Q'ty	Parts No.	Assembly No.
G-1	Screw	2	148768-0-01		G-23	Screw 6.35 x 6	1	014770-6-22	
G-2	Joint	2	148632-0-01		G-24	Tension Release Cam	1	149061-0-01	
G-3	Nut	2	021670-1-02		G-25	Screw 6.35	1	148574-0-01	
G-4	Tension Release Rod Upper	1	148631-0-01		G-26	Cylinder	1	149043-0-01	
G-5	Screw 4.37	2	117160-0-01		G-27	Screw	1	148546-0-01	
G-6	Tension Release Plate	1	148634-0-01		G-28	Packing	3	146699-0-00	
G-7	Tension Release Crank	1	148635-0-01		G-29	Male Connector Assembly	3	149241-0-01	
G-8	Stud Screw 3.57	1	148633-0-01		G-30	Stop Ring E-3	1	048030-3-42	
G-9	Stud Screw 6.35	1	148628-0-01		G-31	Stud 4 x 23.4	1	149056-0-01	
G-10	Tension Release Crank Upper	1	148630-0-01		G-32	Cylinder Supporter	1	149055-0-01	
G-11	Stud	1	148629-0-01		G-33	Screw 3.18 x 7	1	009660-7-12	
G-12	Stud Screw 4.76	1	110171-0-01		G-34	Screw 4.76	2	105173-0-04	
G-13	Spring Hanger	1	115177-0-01		G-35	Air Tube	1	149283-0-00	
G-14	Spring	1	148654-0-01		G-36	Transfer Cylinder	1	149052-0-01	
G-15	Stud Screw	2	123882-0-01		G-37	Screw 3.18	1	117666-0-01	
G-16	Tension Release Connecting Rod Lower	1	148623-0-01		G-38	Transfer Cylinder Nut	1	149281-0-01	
G-17	Tension Release Lever	1	149050-0-01		G-39	Nut 3.57	1	021670-1-02	
G-18	Tension Release Crank Lower	1	148625-0-01		G-40-1	Valve Lever Supporter	1		G-40 Transfer Lever Assembly 149058-0-01
G-19	Stud Screw 6.35	1	148628-0-01		G-40-2	Valve Lever	1		
G-20	Screw 6.35 x 6	2	014770-6-22		G-40-3	Valve Connecting Rod	1		
G-21	Screw 4.76 x 10	2	009711-0-12		G-40-4	Pin	1		
G-22	Tension Release Cylinder Base	1	149049-0-01		G-40-5	Stud 4 x 23.4	1	149056-0-01	
					G-40-6	Stop Ring E-3	2	048030-3-42	

# H. Knife Mechanism

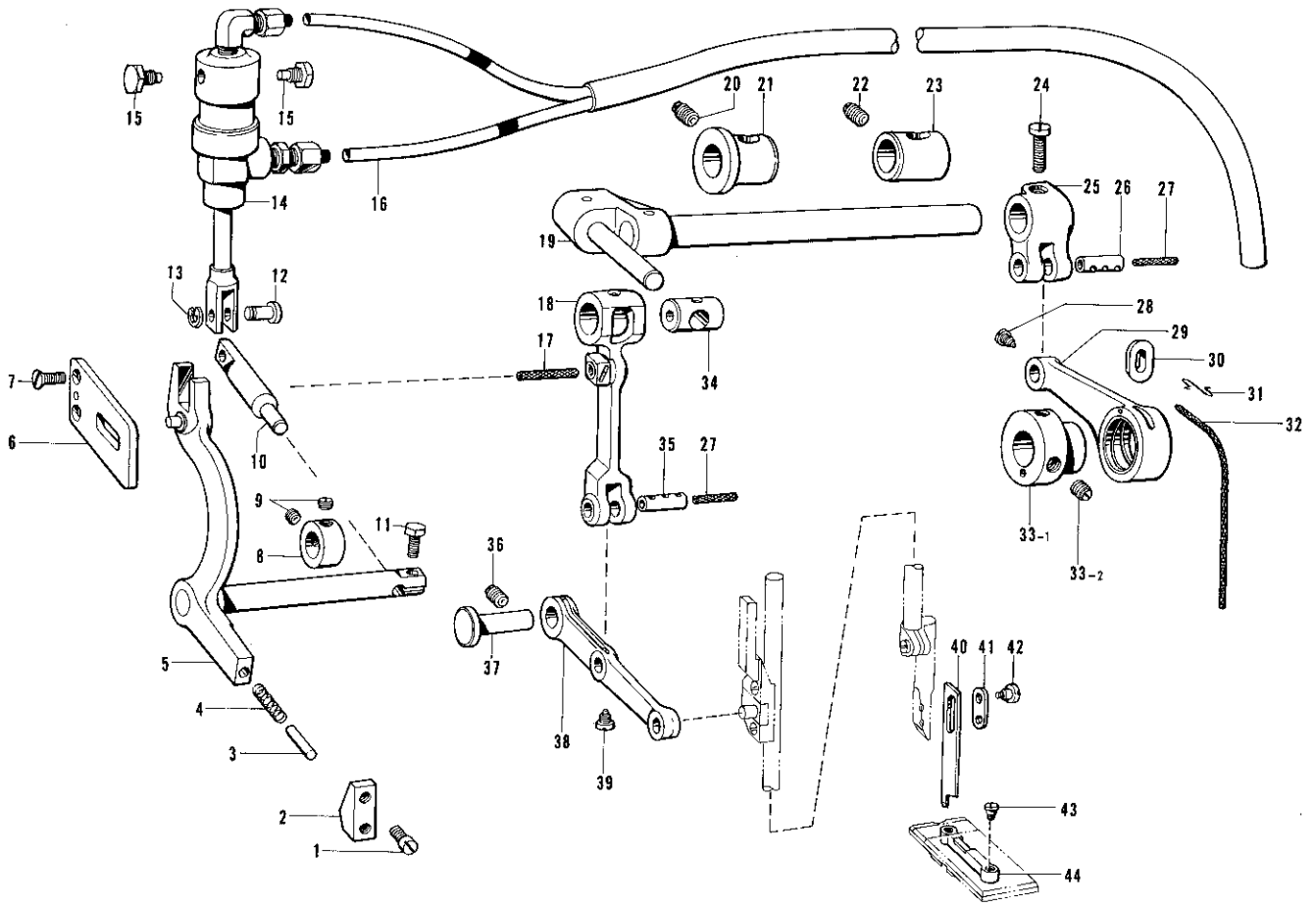

Ref. No.	Name of Parts	Q'ty	Parts No.	Assembly No.	Ref. No.	Name of Parts	Q'ty	Parts No.	Assembly No.
H- 1	Screw 4.37	2	104908-0-02		H-24	Screw 5.56 x 16	1	009751-6-12	
H- 2	Transfer Lever Cam	1	143654-0-01		H-25	Upper Knife Rock Arm	1	153026-0-01	
H- 3	Transfer Lever Pin	1	143655-0-01		H-26	Stud 6.35 x 17	1	143625-0-01	
H- 4	Transfer Lever Spring	1	143656-0-01		H-27	Wick 15 mm	2	112293-0-01	
H- 5	Valve Lever Assembly	1	143647-0-01		H-28	Screw 3.18	1	110563-0-01	
H- 6	Valve Lever Stopper	1	143653-0-01		H-29	Upper Knife Connecting Lever	1	153025-0-01	
H- 7	Screw 4.76	2	107231-0-02		H-30	Oil Seal	1	143676-0-00	
H- 8	Set Collar	1	146581-0-01		H-31	Clip	1	116795-0-00	
H- 9	Set Screw 5.95	2	100260-0-01		H-32	Wick 110 mm	1	153023-0-01	
H-10	Piston Rod Joint	1	155926-0-01		H-33- 1	Eccentric Wheel	1		H-33 Eccentric Wheel with Screw 153015-0-01
H-11	Bolt 4.37 x 10	1	017681-0-14		H-33- 2	Screw 5.95	2	151604-0-01	
H-12	Pin	1	146153-0-01		H-34	Slide Block Driving Stud	1	143635-0-00	
H-13	Stop Ring E-4	1	048040-3-42		H-35	Stud 6.35 x 17	1	143625-0-01	
H-14	Upper Knife Cylinder Assembly	1	155929-0-01		H-36	Screw 5.95	1	151605-0-01	
H-15	Screw	2	140620-0-01		H-37	Connecting Lever Shaft	1	143638-0-01	
H-16	Air Tube Assembly	1	154491-0-01		H-38	Upper Knife Connecting Lever	1	153029-0-01	
H-17	Wick 25 mm	1	153024-0-00		H-39	Screw 3.18	1	110563-0-01	
H-18	Upper Knife Connecting Rod Assembly	1	153017-0-01		H-40	Upper Knife	1	153019-0-01	
H-19	Upper Knife Rock Shaft	1	153027-0-01		H-41	Upper Knife Presser	1	143641-0-01	
H-20	Screw 5.95	1	151604-0-01		H-42	Presser Screw	2	143642-0-01	
H-21	Left Bushing for Upper Knife Rock Shaft	1	143627-0-00		H-43	Stud Screw 2.38	2	148539-0-01	
H-22	Screw 5.95	1	151604-0-01		H-44	Fixed Knife	1	155928-0-01	
H-23	Right Bushing for Upper Knife Rock Shaft	1	143626-0-00						

# J. Corner Cutter Mechanism (Model 600V)

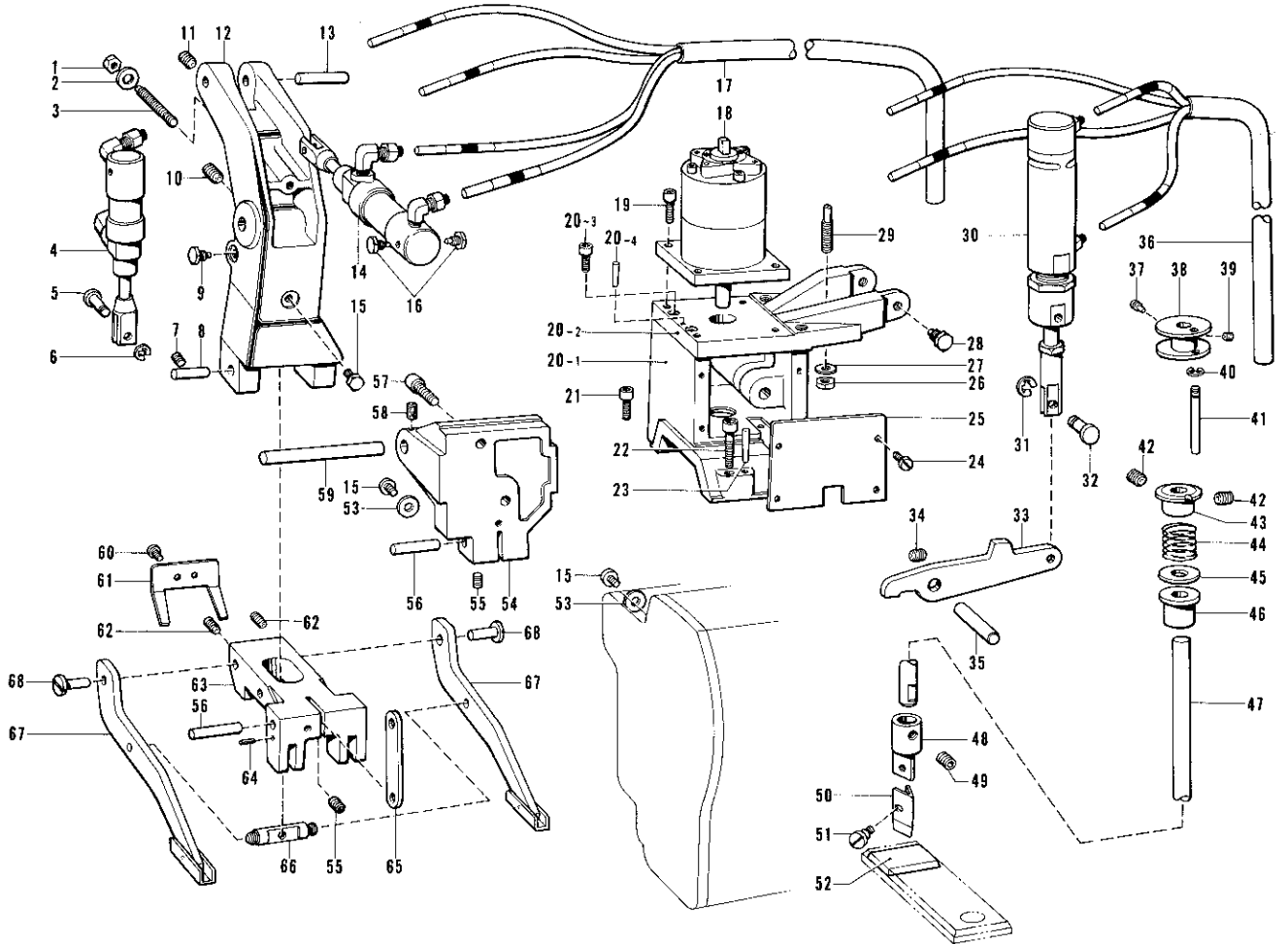

Ref. No.	Name of Parts	Q'ty	Parts No.	Assembly No.	Ref. No.	Name of Parts	Q'ty	Parts No.	Assembly No.
J- 1	Nut 6	1	021060-1-02		J-34	Screw 6.35 x 6	1	014770-6-22	
J- 2	Washer 6	1	025060-2-32		J-35	Stud 8 x 38.8	1	155897-0-01	
J- 3	Adjusting Screw	1	155915-0-01		J-36	Air Tube Assembly	1	156020-0-00	
J- 4	Finger Cylinder Assembly	1	155916-0-01		J-37	Screw 3.57	1	155890-0-01	
J- 5	Pin	1	146153-0-01		J-38	Upper Bushing	1	155889-0-01	
J- 6	Stop Ring E-4	1	048040-3-42		J-39	Screw 3.57	1	148294-0-01	
J- 7	Screw 4.37 x 6	2	014680-6-22		J-40	Stop Ring E-4	2	048040-3-42	
J- 8	Stud 6.5 x 19.8	2	155923-0-01		J-41	Pin	1	155891-0-01	
J- 9	Screw	2	140620-0-01		J-42	Screw 3.57	2	148294-0-01	
J-10	Screw 6.35 x 6	1	014770-6-22		J-43	Lower Bushing	1	155899-0-01	
J-11	Screw 4.37 x 6	1	014680-6-22		J-44	Cutter Spring	1	155900-0-01	
J-12	Finger Arm	1	155907-0-01		J-45	Washer	1	141343-0-01	
J-13	Stud 6 x 31.8	1	155914-0-01		J-46	Cutter Bushing	1	155902-0-00	
J-14	Cylinder Assembly	1	155909-0-01		J-47	Cutter Bar	1	155898-0-01	
J-15	Bolt 5.95	3	110087-0-01		J-48	Cutter Setting Bar	1	155903-0-01	
J-16	Screw	2	140620-0-01		J-49	Screw 3.57	1	148294-0-01	
J-17	Air Tube Assembly	1	156021-0-00		J-50	Corner Cutter 10	1	155904-0-01	
J-18	V Cut Rotor Assembly	1	155887-0-01		J-51	Stud Screw 2.38	2	145371-0-01	
J-19	Bolt 5 x 14	4	018501 4-22		J-52	Corner Cutter Bracket	1	155905-0-00	
J-20- 1	Cutter Bracket	1		J-20	J-53	Washer 5.56	2	025750-2-33	
J-20- 2	Rotor Setting Base	1	155886-0-01	Cutter Bracket Assembly 155884-0-01	J-54	Finger Arm Bracket	1	155906-0-01	
J-20- 3	Bolt	4	018501-0-22		J-55	Screw 4.37 x 6	2	014680-6-22	
J-20- 4	Pin	2	046301-6-20		J-56	Stud 6 x 31.8	2	155914-0-01	
J-21	Bolt 5 x 25	1	018502-5-22		J-57	Bolt 6 x 20	2	018062-0-22	
J-22	Bolt 5 x 16	2	018501-6-22		J-58	Felt	2	155973-0-00	
J-23	Pin 5 x 20	2	046502-0-20		J-59	Stud 8.72 x 72	1	155908-0-01	
J-24	Screw 3.57 x 6	4	009670-6-12		J-60	Screw 4.37 x 4.5	2	009689-4-12	
J-25	Cutter Bracket Cover	1	156007-0-01		J-61	Finger Plate Spring	1	155924-0-01	
J-26	Mut 5.95	1	106588-0-01		J-62	Screw 4.37 x 6	2	014680-6-22	
J-27	Washer 5.56	1	025750-2-33		J-63	Arm Plate	1	155922-0-01	
J-28	Screw	2	140620-0-01		J-64	Spring Pin AW3	2	047301-8-42	
J-29	Screw 5.95	1	117685-0-01		J-65	Finger Link	1	155925-0-01	
J-30	Cutter Cylinder Assembly	1	155892-0-01		J-66	Finger Connecting Rod	1	155917-0-01	
J-31	Stop Ring E-4	1	048040-3-42		J-67	Finger Assembly	2	155918-0-01	
J-32	Pin	1	146153-0-01		J-68	Pin	2	118713-0-01	
J-33	Cutter Lever	1	155896-0-01						

# K. Lubrication

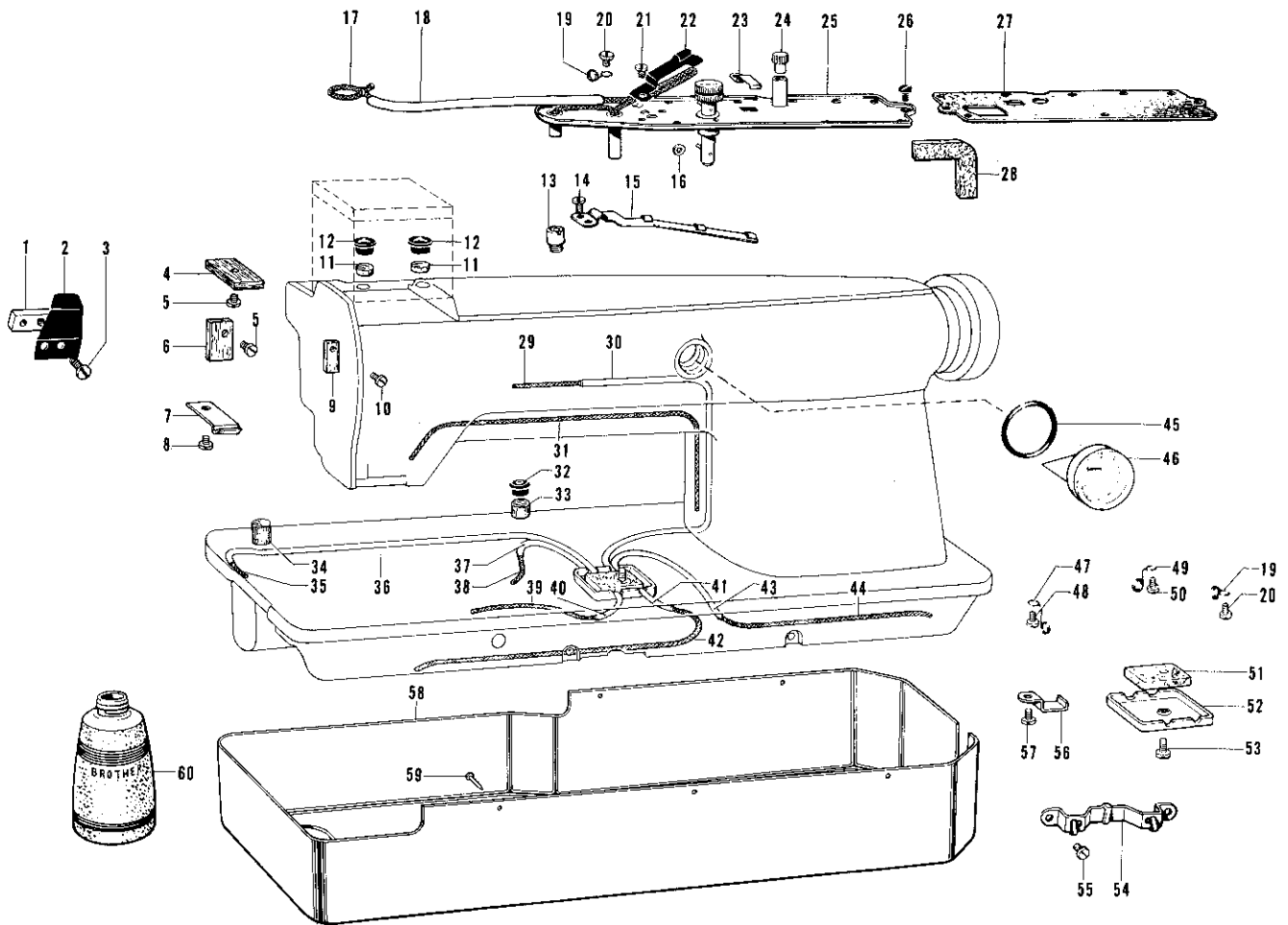

Ref. No.	Name of Parts	Q'ty	Parts No.	Assembly No.	Ref. No.	Name of Parts	Q'ty	Parts No.	Assembly No.
K-1	Oil Stopper Plate Presser	1	112717-0-01		K-31	Wick 440 mm	1	112736-0-00	
K-2	Oil Stopper Plate	1	112716-0-01		K-32	Oil Cap	1	112758-0-01	
K-3	Screw 4.76 x 8	1	009710-8-12		K-33	Felt	1	112753-0-01	
K-4	Felt	1	143679-0-00		K-34	Felt	1	112754-0-01	
K-5	Screw 3.57	2	100242-0-03		K-35	Wick 375 mm	1	148742-0-00	
K-6	Felt	1	143702-0-00		K-36	Oil Tube	1	148741-0-01	
K-7	Oil Stopper Plate	1	143677-0-01		K-37	Oil Tube	1	148733-0-01	
K-8	Screw 3.57	1	100242-0-03		K-38	Wick 160 mm	1	148740-0-00	
K-9	Felt	1	148762-0-01		K-39	Wick 300 mm	1	148736-0-00	
K-10	Screw 3.57 x 6	1	001670-6-12		K-40	Oil Tube	1	148735-0-01	
K-11	Felt	2	143936-0-00		K-41	Oil Tube	1	148737-0-01	
K-12	Oil Cap	2	140890-0-01		K-42	Wick 335 mm	1	148738-0-00	
K-13	Oil Tube Guide	1	113524-0-01		K-43	Oil Tube	1	148733-0-01	
K-14	Screw 3.18	2	106640-0-01		K-44	Wick 310 mm	1	148734-0-00	
K-15	Wick Holder	1	143657-0-01		K-45	O Ring	1	081016-0-70	
K-16	Washer	1	503093-0-01		K-46	Oil Gauge Window	1	116558-0-01	
K-17	Wick	1	155972-0-00		K-47	Wick Holder	1	112745-0-01	
K-18	Oil Tube	1	151084-0-00		K-48	Set Screw 3.57 x 5	1	009670-5-12	
K-19	Tube Holder	4	112743-0-01		K-49	Tube Stopper	1	112744-0-01	
K-20	Screw 3.57 x 5	3	009670-5-12		K-50	Set Screw 3.57 x 5	1	009670-5-12	
K-21	Screw 3.57 x 3.5	1	009679-3-12		K-51	Felt	1	148732-0-01	
K-22	Spring Plate	1	112730-0-01		K-52	Oil Tube Supporter	1	148729-0-01	
K-23	Felt Presser	1	114297-0-01		K-53	Screw 4.76 x 10	1	009711-0-12	
K-24	Cap for Oil Inlet	1	113526-0-01		K-54	Wick Support	1	143673-0-01	
K-25	Oil Receiver Plate Assembly	1	155970-0-01		K-55	Screw 3.18 x 4	2	009660-4-12	
K-26	Screw 3.57 x 6	10	009670-6-12		K-56	Felt Presser	1	114297-0-01	
K-27	Packing	1	112723-0-01		K-57	Set Screw 3.57	1	009670-5-12	
K-28	Felt	1	112724-0-01		K-58	Oil Pan	1	151007-1-01	
K-29	Wick 720 mm	1	148731-0-00		K-59	Nail	5	109714-0-00	
K-30	Oil Tube	1	148730-0-01		K-60	Oiler	1	114486-0-01	

# L. Synchronizer Mechanism

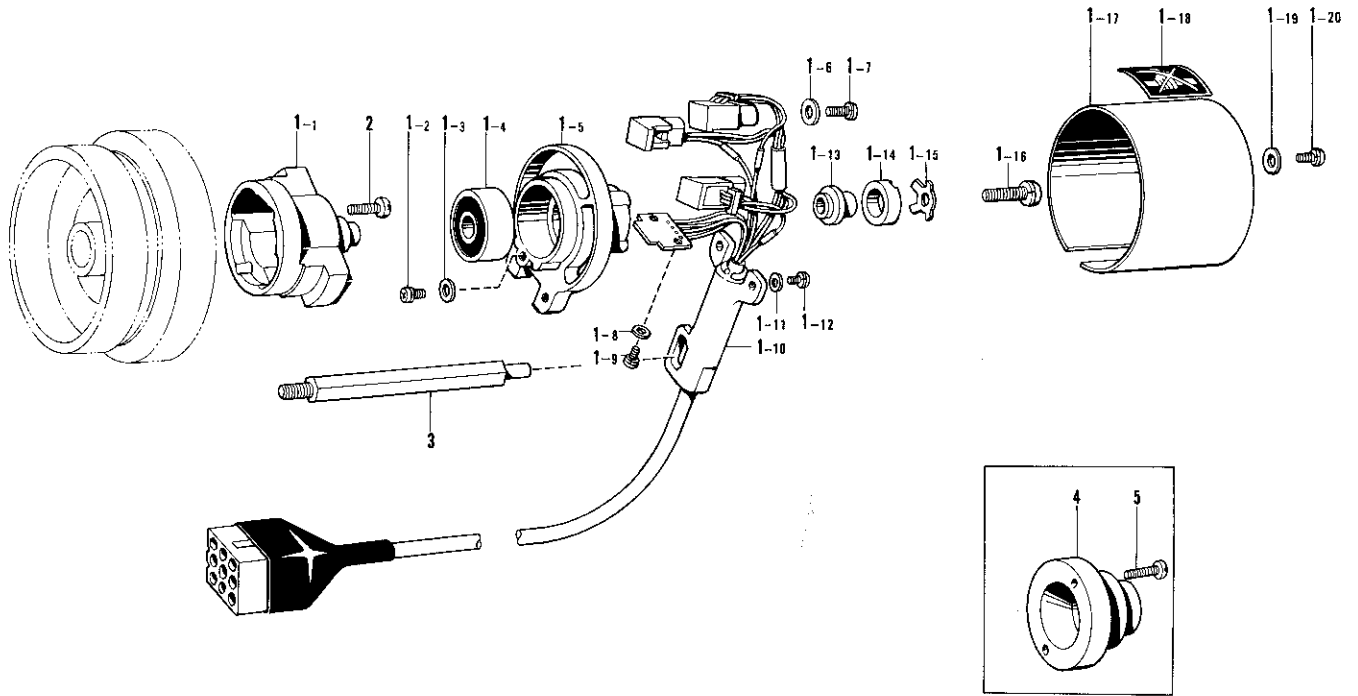

Ref. No.	Name of Parts	Q'ty	Parts No.	Assembly No.	Ref. No.	Name of Parts	Q'ty	Parts No.	Assembly No.
L- 1- 1	Synchronizer Shaft Assembly	1		L-1 Synchronizer #7 222370-0-01	L- 1-12	Screw 4 x 10D	2	215080-0-01	L-1 Synchronizer #7 222370-0-01
L- 1- 2	Screw 3 x 6D	1	215083-0-01		L- 1-13	Magnet Setting Bracket	1	219557-0-00	
L- 1- 3	Washer 3	1	025030-3-35		L- 1-14	Magnet	1	219558-0-00	
L- 1- 4	Bearing 6201 VV	1			L- 1-15	Magnet Holder Plate	1	219559-0-00	
L- 1- 5	Synchronizer Holder	1			L- 1-16	Screw 6 x 25D	1	221421-0-01	
L- 1- 6	Washer 4	2	025040-3-35		L- 1-17	Synchronizer Cover #3	1		
L- 1- 7	Screw 4 x 12D	3	217093-0-01		L- 1-18	Label	1		
L- 1- 8	Washer 3	2	025030-1-35		L- 1-19	Washer 4	3	025040-3-35	
L- 1- 9	Screw 3 x 6D	2	215083-0-01		L- 1-20	Screw 4 x 10D	2	215080-0-01	
L- 1-10	Hole I.C with Cord	1			L- 2	Screw 4.76 x 14	2	009711-4-12	
L- 1-11	Washer 3	2	025040-1-35		L- 3	Synchronizer Holder Stud	1	148615-0-01	

# M. Valve Box Mechanism

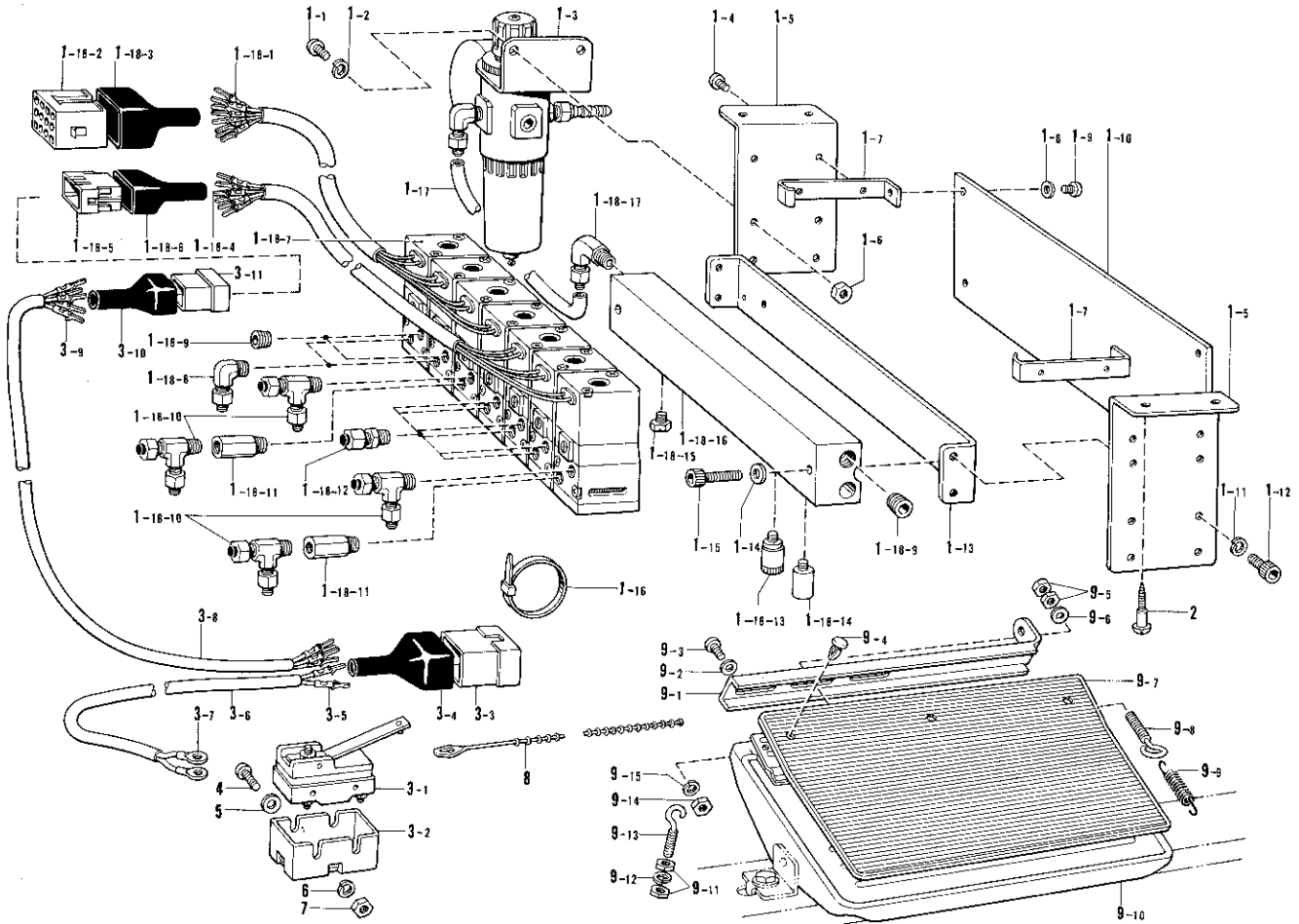

Ref. No.	Name of Parts	Q'ty	Parts No.	Assembly No.	Ref. No.	Name of Parts	Q'ty	Parts No.	Assembly No.
M-1-1	Screw 5 x 10	2	002501-0-64	M-1 Valve Box Assembly 155974-0-01	M-1-18-10	Air Tube Connector	4	140544-0-00	M-18 Solenoid Valve Assembly 155977-0-01
M-1-2	Spring Washer 2-5	2	028050-2-43		M-1-18-11	Valve Connector	2	140539-0-00	
M-1-3	Air Unit Assembly	1	154765-0-02		M-1-18-12	1/8" Connector	6	140543-0-00	
M-1-4	Screw 3 x 6	4	002300-6-13		M-1-18-13	Adjusting Valve	2	153268-0-01	
M-1-5	Side Plate	2			M-1-18-14	Silencer	10	153269-0-01	
M-1-6	Nut 5	2	021500-1-63		M-1-18-15	Cap Screw M5	2	156096-0-00	
M-1-7	Plate Supporter	2			M-1-18-16	Solenoid Valve Base	1	155979-0-01	
M-1-8	Washer 3	4	025030-2-33		M-1-18-17	1/8" Elbow	1	151147-0-01	
M-1-9	Screw 3 x 6	4	002300-6-13		M-2	Screw 5.5 x 20	4	100666-0-02	M-3 Presser Foot Lifter Cord Assembly 156099-0-01
M-1-10	Rear Plate	1			M-3-1	Micro Switch	1	140948-0-01	
M-1-11	Spring Washer 2-5	4	028050-2-42		M-3-2	Cover	1	140950-0-00	
M-1-12	Bolt 5 x 8	4	018500-8-22		M-3-3	Nylon Connector 12P	1	153969-0-00	
M-1-13	Valve Setting Plate V	1			M-3-4	Connector Cap 5	1	153971-0-01	
M-1-14	Washer 5	2	025050-1-32		M-3-5	Male Terminal	8	143549-0-00	
M-1-15	Bolt 5 x 30	2	018503-0-22		M-3-6	Presser Foot Lifter Cord	1		
M-1-16	Binder M150	1	218859-0-01		M-3-7	Terminal Pin	2	140693-0-00	
M-1-17	Air Tube	1	140540-0-00		M-3-8	Valve Cord	1	155981-0-00	
M-1-18-1	Male Terminal	8	143549-0-00	M-3-9	Female Terminal	6	143548-0-00		
M-1-18-2	Nylon Connector 12P	1	153433-0-00	M-3-10	Connector Cover #5	1	216384-0-01		
M-1-18-3	Connector Cover #15	1	221786-0-01	M-3-11	Nylon Connector 6P	1	216382-0-01		
M-1-18-4	Female Terminal	6	143549-0-00	M-4	Screw 3 x 30	2	002303-0-06		
M-1-18-5	Nylon Connector 6P	1	216323-0-01	M-5	Washer 3	2	025030-2-33		
M-1-18-6	Connector Cover	1	216324-0-01	M-6	Washer 2-3	2	028030-2-43		
M-1-18-7	Solenoid Valve	7	155978-0-01	M-7	Nut 3	2	021300-1-03		
M-1-18-8	Cylinder Elbow P7 1/8	2	140599-0-00	M-8	Bead Band	1			
M-1-18-9	Cap	3	153274-0-01						

# N. Lupper Mechanism

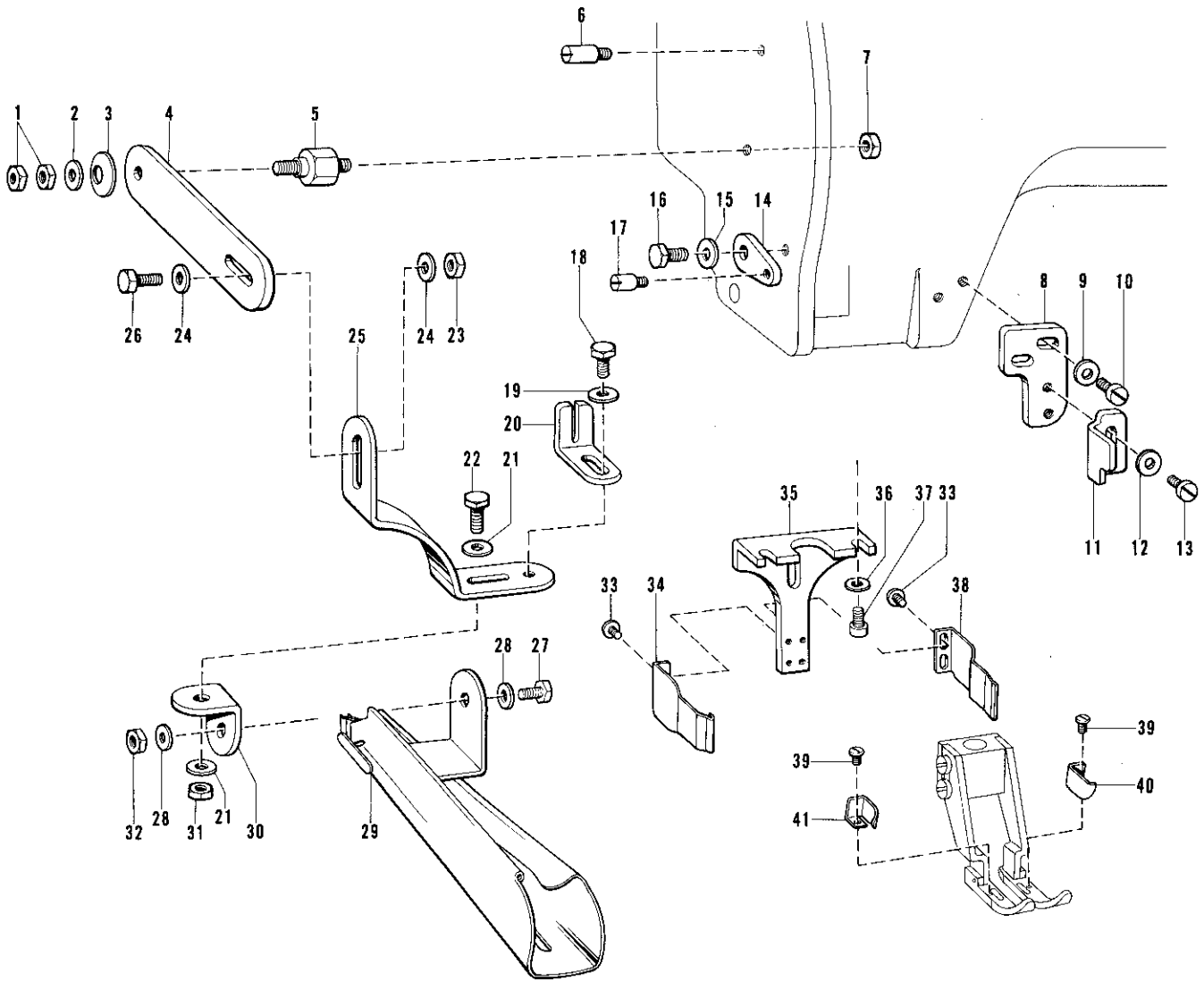

Ref. No.	Name of Parts	Q'ty	Parts No.	Assembly No.	Ref. No.	Name of Parts	Q'ty	Parts No.	Assembly No.
N- 1	Nut 5.95	2	150553-0-01		N-22	Bolt 5.95 x 12	1	017761-2-12	
N- 2	Washer	1	025060-2-32		N-23	Nut 5.95	1	150553-0-01	
N- 3	Washer	1	115017-0-01		N-24	Washer	2	025060-2-32	
N- 4	Lupper Guide Link	1	155948-0-01		N-25	Lupper Setting Plate (U)	1	155949-0-01	
N- 5	Stud	1	155947-0-01		N-26	Bolt 5.95 x 12	1	017761-2-12	
N- 6	Stud	1	150721-0-02		N-27	Bolt 5.95 x 12	1	017761-2-12	
N- 7	Nut 5.95	1	150553-0-01		N-28	Washer	2	025060-2-32	
N- 8	Positioning Plate C	1	155953-0-01		N-29	Lupper Assembly	1	155962-0-00	
N- 9	Washer 4.37	2	100645-0-03		N-30	Lupper Setting Plate (D)	1	155950-0-01	
N-10	Screw 4.37 x 8	2	009680-8-12		N-31	Nut 5.95	1	150553-0-01	
N-11	Positioning Plate B	1	155952-0-01		N-32	Nut 5.95	1	150553-0-01	
N-12	Washer 4.37	1	100645-0-03		N-33	Screw 2.38	4	100105-0-02	
N-13	Set Screw 4.37 x 6	1	009680-6-12		N-34	Knife Guard Plate (Left)	1	155969-0-00	
N-14	Adjusting Plate	1	115558-0-02		N-35	V Cutter Guard Supporter	1	155967-0-01	
N-15	Washer	1	025060-2-32		N-36	Washer	2	100645-0-03	
N-16	Bolt 5.95 x 8	1	017760-8-12		N-37	Bolt 4 x 8	2	018400-8-22	
N-17	Screw	1	155954-0-01		N-38	Knife Guard Plate (Right)	1	155968-0-00	
N-18	Bolt 5.95 x 8	1	017760-8-12		N-39	Screw 2.38	2	100105-0-02	
N-19	Washer A	1	025060-2-32		N-40	Presser Foot Guide Plate (Right)	1	155965-0-01	
N-20	Positioning Plate A	1	155951-0-01		N-41	Presser Foot Guide Plate (Left)	1	155966-0-01	
N-21	Washer	2	025060-2-32						

# Z. Accessories

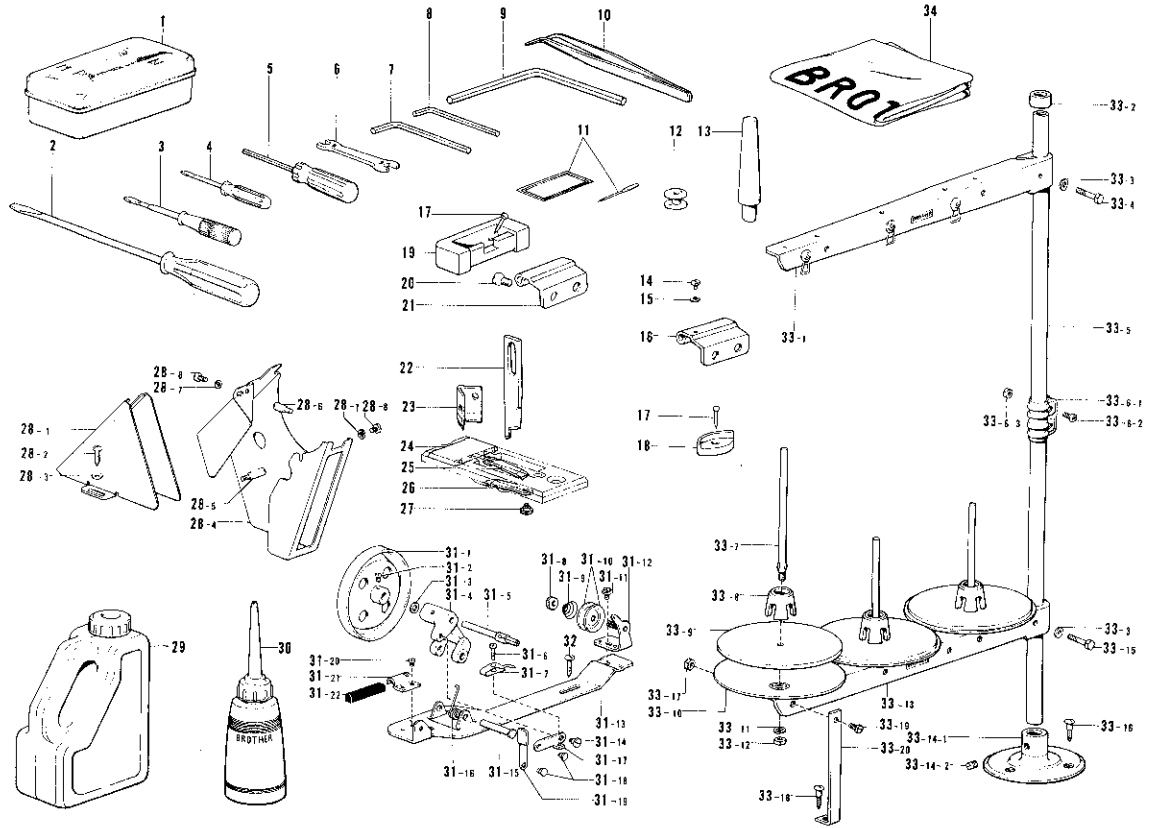

Ref. No.	Name of Parts	Q'ty	Parts No.	Assembly No.	Ref. No.	Name of Parts	Q'ty	Parts No.	Assembly No.
Z- 1	Accessory Box Assembly		110436-0-01		Z-31- 7	Bobbin Presser		100656-0-01	Z-31 Bobbin Winder Assembly 117963-0-01
Z- 2	Screw Driver 5.5 x 190		101572-1-01		Z-31- 8	Tension Control Nut		100136-0-02	
Z- 3	Screw Driver 3.4 x 70		118837-0-01		Z-31- 9	Tension Spring		100401-0-01	
Z- 4	Screw Driver 1.9 x 52		142443-0-01		Z-31-10	Tension Disc		145446-0-01	
Z- 5	Screw Driver 1.6		144124-0-01		Z-31-11	Screw 4.37		149168-0-01	
Z- 6	Spanner 8 x 9		100887-0-01		Z-31-12	Bobbin Winder Guide Assembly		117965-0-01	
Z- 7	Spanner 3		142721-0-01		Z-31-13	Bobbin Winder Wheel Bracket		117964-0-01	
Z- 8	Allen Wrench (2 mm)		142002-0-01		Z-31-14	Stud Screw 3.18		100659-0-01	
Z- 9	Spanner		149570-0-01		Z-31-15	Pin		117968-0-01	
Z-10	Tweezers		117466-0-00		Z-31-16	Spring		117969-0-01	
Z-11	Needle Assembly MT x 190		153011-4-16		Z-31-17	Bobbin Presser Arm		100658-0-01	
Z-12	Bobbin		148603-0-01		Z-31-18	Pin		100661-0-01	
Z-13	Head Rest		149010-0-00		Z-31-19	Bobbin Presser Bracket		100660-0-01	
Z-14	Screw 4.37 x 6		009680-6-13		Z-31-20	Screw 3.57 x 3.5		009679-3-12	
Z-15	Washer 4.37		025680-2-34		Z-31-21	Bobbin Winder Wheel Stopper Hold		100664-0-01	
Z-16	Hinge E		150557-0-01		Z-31-22	Bobbin Winder Wheel Stopper		100662-0-01	
Z-17	Nail		109714-0-00		Z-32	Screw 5.5 x 20		100666-0-02	
Z-18	Head Cushion		148890-1-01		Z-33- 1	Thread Hanger Assembly 3		150193-0-01	
Z-19	Rubber Hinge		143910-0-01		Z-33- 2	Cap		150174-0-00	
Z-20	Screw 6.35		112569-0-01		Z-33- 3	Washer		025050-2-33	
Z-21	Head Hinge		148882-0-01		Z-33- 4	Bolt		017502-8-03	
Z-22	Upper Knife		153019-0-01		Z-33- 5	Pipe		150172-0-01	
Z-23	Corner Cutter 10		155904-0-01		Z-33- 6-1	Joint		150173-0-01	
Z-24	Corner Cutter Support		155905-0-00		Z-33- 6-2	Screw 5 x 14		150202-0-01	Z-33-6 Joint for Cotton Stand 150106-0-01
Z-25	Fixed Knife Right		149169-0-01		Z-33- 6-3	Nut 5		021500-1-03	
Z-26	Fix Knife Left		148538-0-01		Z-33- 7	Spool Shaft (B)		150179-0-01	Z-33-14 Cotton Stand Base Assembly 150139-0-01
Z-27	Stud Screw 2.38		148539-0-01		Z-33- 8	Spool Cushion		126863-0-00	
Z-28- 1	Belt Cover D		147854-0-01	Z-28 Belt Cover Complete D 147908-0-01	Z-33- 9	Spool Mat		150182-0-00	
Z-28- 2	Screw 5.5 x 20		100666-0-02		Z-33-10	Spool Stand Base		150180-0-00	
Z-28- 3	Washer 5.5		025750-1-32		Z-33-11	Spring Washer 2-5		028050-2-43	
Z-28- 4	Belt Cover Up		147852-0-01		Z-33-12	Nut 5		021500-1-03	
Z-28- 5	Belt Cover Stud (B)		147856-0-02		Z-33-13	Spool Holder 3		150175-0-01	
Z-28- 6	Stud (D)		147858-0-01		Z-33-14-1	Cotton Stand Base		150189-0-01	
Z-28- 7	Spring Washer 2-4.37		028680-2-42		Z-33-14-2	Screw 6 x 7		150181-1-01	
Z-28- 8	Screw 4.37 x 8		009680-8-12		Z-33-15	Bolt 5 x 28		017502-8-03	
Z-29	Oil Tank		154702-0-01	Z-33-16	Screw 4.5 x 22		031452-2-03		
Z-30	Oiler		114483-0-01	Z-33-17	Nut 5		021500-1-03		
Z-31- 1	Bobbin Winder Wheel Assembly		117971-0-01	Z-31 Bobbin Winder Assembly 117963-0-01	Z-33-18	Screw 4.5 x 22		031452-2-03	
Z-31- 2	Screw 4.37 x 5		100366-0-02		Z-33-19	Screw 5 x 10		007501-0-03	
Z-31- 3	Washer		142711-0-01		Z-33-20	Spool Holder Supporter A		150188-0-01	
Z-31- 4	Bobbin Winder Wheel Shaft Supporter		117967-0-01		Z-34	Head Cover		144222-0-01	
Z-31- 5	Bobbin Winder Shaft		117970-0-01						
Z-31- 6	Screw 3.18		100657-0-01						

# BROTHER I.S.M.

## TECHNICAL INFORMATION

**BROTHER INDUSTRIES, LTD.**

HEAD OFFICE: No. 35, 9-CHOME,  
HORITA-DORI, MIZUHO-KU, NAGOYA, JAPAN (467)  
CABLE: BROTHER, NAGOYA,  
TELEX: J59908; J59970 & J59743 BROTHER

■ NO. 27.

■ DATE 1982.3.10

■ CLASIFICACIONES

B

### GAUGE PARTS LIST

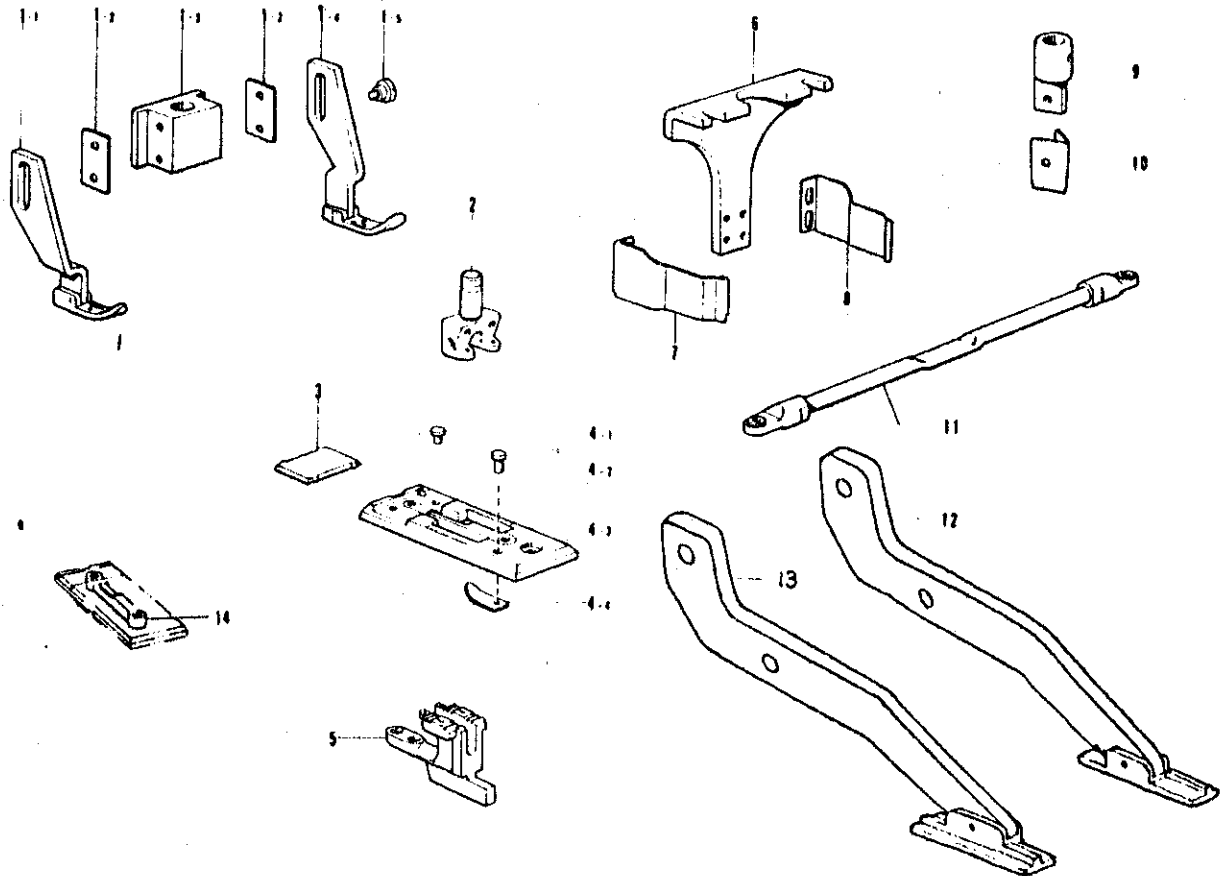

Ref. No.	Name of Parts	Model 600V				Model 600
		8 mm	10 mm	12 mm	16 mm	20 mm
1	Presser Foot Assembly	156844-001	155937-101	156845-001	156848-001	156856-001
1-1	Presser Foot (Left)		155939-201		156849-001	
1-2	Spacer		155945-001	156846-001		156846-001
1-3	Presser Foot Holder			155938-001		
1-4	Presser Foot (Right)		155942-201		156853-001	
1-5	Screw		143642-101	156847-001	143642-101	156847-001
2	Needle Clamp	156833-001	153021-001	156059-001	156834-001	156835-001
3	Corner Cutter Support		155905-100			156855-000
4	Needle Plate Assembly	156836-001	158787-001	156838-001	156840-001	156842-001
4-1	Pin			148709-001		
4-2	Pin L			155934-001		
4-3	Needle Plate	156837-001	158788-001	156839-001	156841-001	156843-001
4-4	Spring			148708-001		
5	Feed Dog	156857-001	158789-001	156858-001	156859-001	156850-001
6	V Cutter Guard Support	156863-001		155967-101		
7	Knife Guard Plate (Left)	156865-000	155969-000	156867-000	158405-000	
8	Knife Guard Plate (Right)	156864-000	155968-000	156866-000	158404-000	
9	Cutter Setting Bar	156826-001	155903-001	156827-001	156831-001	
10	Corner Cutter	156828-001	155904-001	156829-001	156862-001	
11	Knife Connecting Bar	149697-001		149685-001	149958-001	150528-001
12	Finger Assembly (R.)		155918-102		156852-002	
13	Finger Assembly (L.)		155918-101		156852-001	
14	Fixed Knife	156832-001		155928-001		

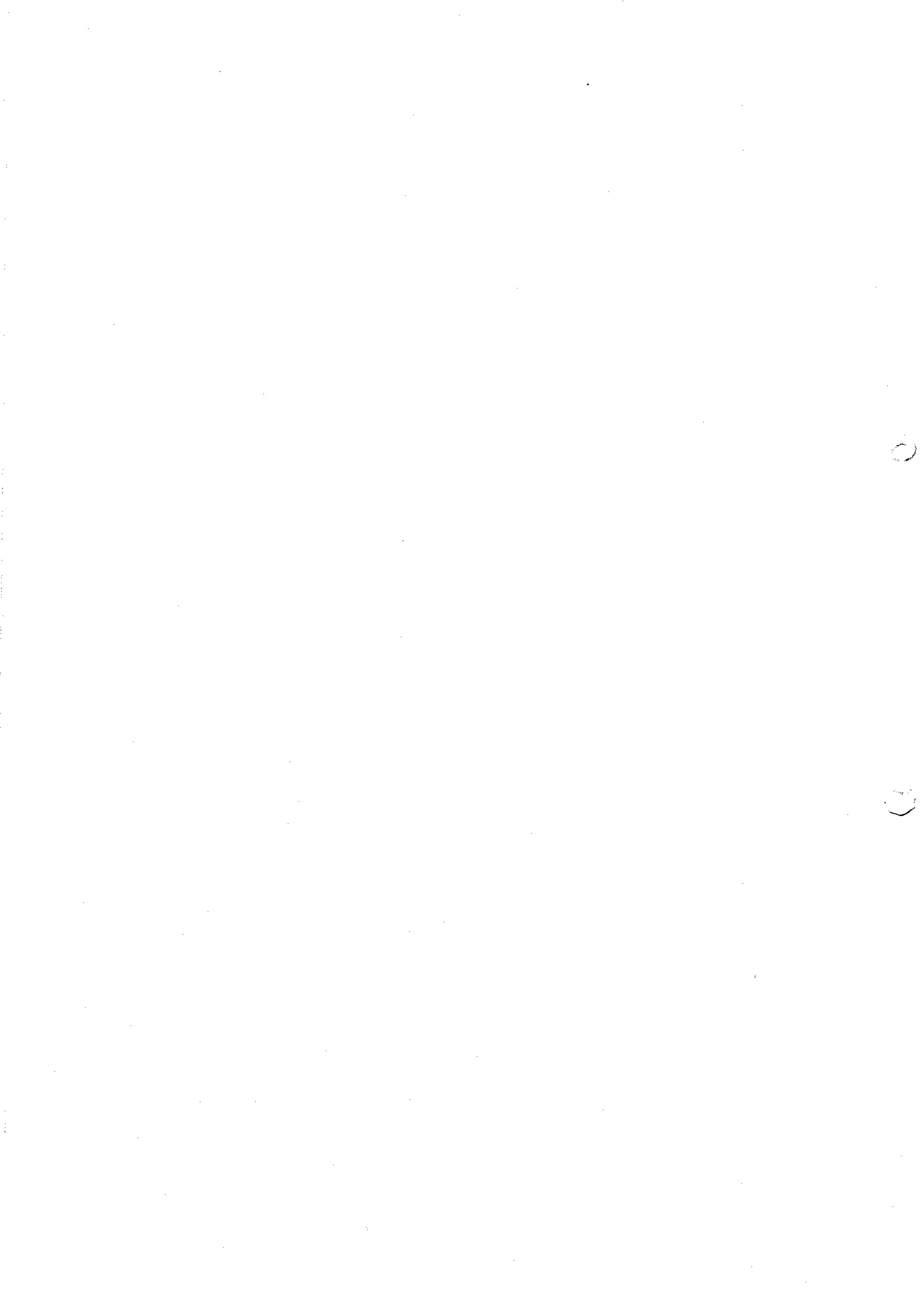

# a. GAUGE PARTS LIST

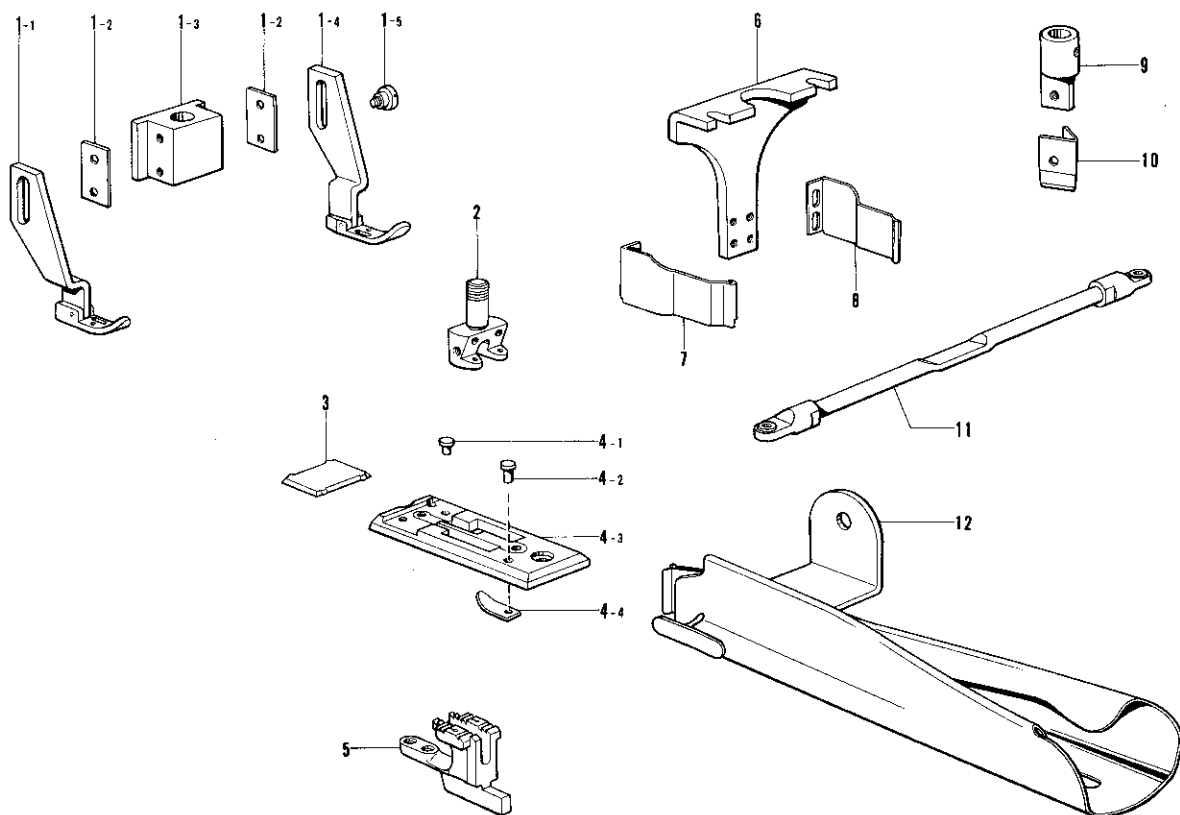

Ref. No.	Name of Parts	Model 600	Model 600V
		10 mm	10 mm
a- 1	Presser Foot Assembly		155937-0-01
a- 1- 1	Presser Foot (Left)		155939-0-01
a- 1- 2	Spacer		155945-0-01
a- 1- 3	Presser Foot Holder		155938-0-01
a- 1- 4	Presser Foot (Right)		155942-0-01
a- 1- 5	Screw		143642-0-01
a- 2	Needle Clamp		153021-0-01
a- 3	Corner Cutter Support		
a- 4	Needle Plate Assembly	155932-0-01	155935-0-01
a- 4- 1	Pin		148709-0-01
a- 4- 2	Pin L		155934-0-01
a- 4- 3	Needle Plate	155933-0-01	155936-0-01
a- 4- 4	Spring		148708-0-01
a- 5	Feed Dog		155946-0-01
a- 6	V Cutter Guard Supporter		155967-0-01
a- 7	Knife Guard Plate (Left)		155969-0-00
a- 8	Knife Guard Plate (Right)		155968-0-00
a- 9	Cutter Setting Bar		155903-0-01
a-10	Corner Cutter		155904-0-01
a-11	Knife Connecting Bar Assembly		149697-0-01
a-12	Lapper Assembly	155955-0-00	155956-0-00

## DIFFERENT PARTS LIST

Ref. No.	Name of Parts	Model 600	Model 600V
A- 4	Thread Take-up Cover	112561-0-02	156058-0-01
A- 6	Stud (B)		147856-0-01
A- 7	Screw 4.37 x 8	009681-6-13	009680-8-13
A- 8	Arm Top Cover	143572-0-02	155872-0-01
A-41	Arm Top Sub-cover	143574-0-01	
A-42	Screw 3.18 x 4	009660-4-12	
A-43	Screw 3.57 x 6	009670-6-12	
A-44	Bracket Cover	155876-0-01	
B-57	Needle Plate Assembly	155932-0-01	155935-0-01
H-44	Fixed Knife	155927-0-01	155928-0-01
K-17	Wick	112725-0-01	155972-0-00
K-18	Oil Tube		151084-0-01
K-25	Oil Receiver Plate Assembly	112762-0-01	155970-0-01
M- 1	Valve Box Assembly	156093-0-01	155974-0-01
M- 1-18	Solenoid Valve Assembly	155984-0-01	155977-0-01
M- 1-18- 4	Female Terminal		143549-0-00
M- 1-18- 5	Nylon Connector 6P		216323-0-01
M- 1-18- 6	Connector Cover		216324-0-01
M- 1-18- 8	Cylinder Elbow P7 1/8		140599-0-00
M- 3	Presser Foot Lifter Cord	156098-0-01	156099-0-01
M- 3- 4	Connector Cap 5	153970-0-01	153971-0-01
M- 3- 8	Valve Cord		155981-0-00
M- 3- 9	Female Terminal		143548-0-00
M- 3-10	Connector Cover #5		216384-0-01
M- 3-11	Nylon Connector 6P		216382-0-01
N-29	Lapper Assembly	155955-0-00	155962-0-00
N-33	Screw 2.38		100105-0-02
N-34	Knife Guard Plate (Left)		155969-0-00
N-35	V Cutter Guard Supporter		155967-0-01
N-36	Washer		100645-0-03
N-37	Bolt 4 x 8		018400-8-22
N-38	Knife Guard Plate (Right)		155968-0-00
Z-23	Corner Cutter		155904-0-01
Z-24	Corner Cutter Support		155905-0-01
K-19	Tube Holder	3	4
K-20	Screw 3.75 x 5	2	3
M- 1-18- 7	Solenoid Valve	4	7
M- 1-18-10	Air Tube Connector	2	4
M- 1-18-11	Valve Connector	1	2
M- 1-18-12	1/8" Connector	4	6
M- 1-18-13	Adjusting Valve	1	2
M- 1-18-14	Silencer	5	10
M- 3- 5	Male Terminal	2	8

# INDEX

Parts No.	Ref. No.	Remark	Parts No.	Ref. No.	Remark	Parts No.	Ref. No.	Remark	Parts No.	Ref. No.	Remark
001630-4-02	F- 1		013771-2-12	E-14		028050-2-43	M- 1-11		105173-0-04	G-34	
001670-6-12	K-10		013780-7-10	E- 9			Z-33-11		105234-0-01	E-15	
002300-6-13	M- 1- 4		014680-4-22	C-62		028680-2-42	Z-28- 7		105351-0-02	B-33	
	M- 1- 9		014680-6-22	J- 7		028680-2-43	E-16		105955-0-01	B-59	
002303-0-06	M- 4			J-11		031452-2-03	Z-33-16		106588-0-01	J-26	
002501-0-64	M- 1- 1			J-55			Z-33-18		106640-0-01	K-14	
005671-2-12	E-11			J-62		046301-6-20	J-20- 4		107030-0-01	B-50- 5	
007501-0-03	Z-33-19		014760-6-22	C-56		046502-0-20	J-23		107155-0-01	E-49	
009660-4-12	A-42		014770-6-22	F-41		047201-0-42	F-35- 4		107231-0-02	A- 5	
	B-44			G-20		047301-8-42	J-64			H- 7	
	B-47			G-23		048030-3-42	G-30		107278-0-02	D-47	
	K-55			J-10			G-40- 6		107794-0-01	E-36	
009660-7-12	G-33			J-34		048040-3-42	C-33			E-43	
009670-5-12	B-36		015771-0-12	C-49			C-40		108254-0-01	A-17- 9-14	
	K-20		015771-2-12	B-26			F-27		108263-0-01	A-17- 9- 2	
	K-48		017502-8-03	Z-33- 4			H-13		108265-0-01	A-17- 9- 5	
	K-50			Z-33-15			J- 6		108266-0-01	A-25	
	K-57		017681-0-14	H-11			J-31		108549-0-01	D-12	
009670-6-12	A-12		017760-8-12	N-16			J-40		108960-0-04	A-26	
	A-20			N-18		048060-3-42	D-34			A-30	
	A-43		017761-2-12	N-22		048070-3-42	D- 3			A-32	
	J-24			N-26		072620-4-60	B-29		109714-0-00	K-59	
	K-26			N-27		081016-0-70	K-45			Z-17	
009670-7-12	B-50-16		018061-6-22	F-13		100064-0-02	A-21		110087-0-01	J-15	
009670-8-12	A- 2		018062-0-22	J-57		100105-0-02	N-33		110161-0-06	E-46	
	B-50- 9		018400-8-22	N-37			N-39		110171-0-01	C-37	
	B-50-13		018500-8-22	M- 1-12		100136-0-02	Z-31- 8			G-12	
	E-55		018501-0-22	J-20- 3		100242-0-03	D-53		110436-0-01	Z- 1	
	F-20		018501-4-22	J-19			K- 5		110563-0-01	H-28	
	F-23		018501-6-22	J-22			K- 8			H-39	
009679-3-12	K-21		018502-5-22	J-21		100248-0-01	B-23		112072-0-01	D- 7	
	Z-31-20		018503-0-22	M- 1-15		100250-0-01	B- 8		112293-0-01	H-27	
009680-6-12	N-13		021060-1-02	J- 1		100251-0-01	B- 5		112563-0-01	A- 4	
009680-6-13	Z-14		021300-1-03	M- 7			E-39		112566-0-03	A-13	
009680-7-12	C- 5- 2		021500-103	Z-33- 6- 3		100260-0-01	C- 7		112569-0-01	Z-20	
009680-8-12	N-10			Z-33-12			H- 9		112573-0-01	B-18	
	Z-28- 8			Z-33-17		100320-0-02	E-22		112574-0-00	B- 7	
009680-8-13	A- 7		021500-1-63	M- 1- 6			E-26		112576-0-01	B-19	
009681-0-12	C-60		021660-1-03	D-48		100328-0-01	D-10		112577-0-01	B- 2	
	D-27- 3		021670-1-02	A-17- 1		100366-0-02	Z-31- 2		112578-0-01	B-12	
009681-0-13	A-14			G- 3		100401-0-01	Z-31- 9		112579-0-01	B-10	
009681-0-14	A-18			G-39		100645-0-03	C-59		112586-0-01	B-24	
009681-2-14	C- 3		025030-1-35	L- 1- 8			E-17		112593-0-01	B-50- 6	
009681-6-13	A- 7		025030-2-33	M- 1- 8			N- 9		112594-0-01	B-43	
009689-4-12	J-60			M- 5			N-12		112595-0-00	B-34	
009710-8-12	D-23		025030-3-35	L- 1- 3			N-36		112596-0-01	B-39	
	F- 8		025040-1-35	L- 1-11		100656-0-01	Z-31- 7		112597-0-01	B-38	
	K- 3		025040-3-35	L- 1- 6		100657-0-01	Z-31- 6		112598-0-01	B-40	
009711-0-12	F-40			L- 1-19		100658-0-01	Z-31-17		112606-0-01	B-55	
	G-21		025050-1-32	M- 1-14		100659-0-01	Z-31-14		112607-0-01	B-60	
	K-53		025050-2-33	Z-33- 3		100660-0-01	Z-31-19		112615-0-01	C- 6	
009711-2-12	C-18		025060-1-32	D-50		100661-0-01	Z-31-18		112623-0-01	C-13	
009711-4-12	C-54		025060-2-32	J- 2		100662-0-01	Z-31-22		112624-0-01	C-12	
	F-28			N- 2		100664-0-01	Z-31-21		112626-0-01	C-16	
	F-36			N-15		100666-0-02	M- 2		112630-0-01	C-15	
	L- 2			N-19			Z-28- 2		112631-0-01	C- 9	
009711-6-12	C-42			N-21			Z-32		112656-0-01	D-51	
	F-31			N-24		100887-0-01	Z- 6		112658-0-01	A-29	
009751-6-12	H-24			N-28		101268-0-03	B-37			A-31	
009761-4-12	D-49		025630-1-32	F- 2		101572-1-01	Z- 2		112666-0-00	E- 8- 1	
009781-8-12	B-41		025680-2-34	Z-15		101706-0-01	B- 4		112667-0-01	E- 8- 2	
	D-36		025710-2-32	C-43			D-26- 2		112668-0-01	E-10	
009782-5-12	C-29			E-47			D-38		112684-0-01	E- 5- 2	
013710-7-12	C-28		025750-1-32	Z-28- 3			E-40			E-38	
013761-4-10	B-16		025750-2-33	J-27		102731-0-04	B-50- 4		112686-0-01	E-23	
	B-21			J-53					112687-0-01	E-42	
	B-31			Z-33- 4		104908-0-02	H- 1		112690-0-01	E-37	
	D-32		025770-2-32	E-25		104908-0-04	D-43		112692-0-01	E-50	
	D-40		028030-2-43	M- 6		105161-0-02	E-54		112694-0-01	E-52	
013771-2-12	B-27		028050-2-43	M- 1- 2			F-21		112695-0-01	E-48	

Parts No.	Ref. No.	Remark	Parts No.	Ref. No.	Remark	Parts No.	Ref. No.	Remark	Parts No.	Ref. No.	Remark
112696-0-00	A-15		117971-0-01	Z-31- 1		143645-0-01	B-50-12		148538-0-01	Z-26	
	E-44		118170-1-01	C-11		143647-0-01	H- 5		148539-0-01	F-11	
112697-0-01	E-53		118171-0-01	B-13		143653-0-01	H- 6			H-43	
112698-0-01	E- 8		118317-0-01	A-17- 9- 4		143654-0-01	H- 2			Z-27	
112699-0-01	E-34		118320-0-01	A-17- 9- 9		143655-0-01	H- 3		148546-0-01	G-27	
112700-0-01	E-35		118713-0-01	C-26		143656-0-01	H- 4		148547-0-01	F-16	
112702-0-01	E-21			D-19		143657-0-01	K-15		148555-0-01	F-15	
112709-0-01	A-19			J-68		143673-0-01	K-54		148557-0-01	F-18	
112712-0-01	A-17- 9- 7		118746-0-01	D- 6		143674-0-01	B-48		148559-0-00	F-14	
112713-0-01	A-28		118747-0-01	D- 8		143675-0-01	B-45		148571-0-01	F-38	
112716-0-01	K- 2		118837-0-01	Z- 3		143676-0-00	H-30		148572-0-01	F-44	
112717-0-01	K- 1		118853-0-01	D- 9		143677-0-01	K- 7		148573-0-01	F-42	
112721-0-01	B-50- 7			D-25		143679-0-00	K- 4		148574-0-01	F-43	
112723-0-01	K-27		118954-0-00	D-31- 2		143702-0-00	K- 6			G-25	
112724-0-01	K-28		123882-0-01	G-15		143766-0-01	A-35		148577-0-01	F-37	
112725-0-01	K-17		126863-0-00	Z-33- 8		143910-0-01	Z-19		148580-0-01	F-39	
112728-0-01	B-51		140527-0-01	A- 9		143936-0-00	K-11		148593-0-00	F- 3	
112730-0-01	K-22		140539-0-00	M- 1-18-11		144124-0-01	Z- 5		148599-0-01	B-62	
112734-0-01	B-17		140540-0-00	M- 1-17		144222-0-01	Z-34		148602-0-01	E-31	
112735-0-00	B- 3		140543-0-00	M- 1-18-12		144680-0-01	A-17- 9-16		148603-0-01	E-30	
112735-0-01	B- 9		140544-0-00	M- 1-18-10		144681-0-01	A-17- 9-17			Z-12	
112736-0-00	K-31		140599-0-00	M- 1-18- 8		144682-0-01	A-17- 9-15		148604-0-00	A-27	
112739-0-01	B-35		140620-0-01	C-38		144683-0-01	A-17- 9- 8		148605-0-01	A- 3	
112743-0-01	K-19			C-45		145371-0-01	J-51		148606-0-03	C-51	
112744-0-01	K-49			F-33		145446-0-01	Z-31-10		148607-0-02	C-48	
112745-0-01	K-47			H-15		145502-0-01	D-11		148608-0-01	C-52	
112751-0-02	B-58			J- 9		146141-0-01	B- 6		148609-0-01	C-57	
112753-0-01	K-33			J-16		146153-0-01	C-32		148611-0-01	A-40	
112754-0-01	K-34			J-28			C-39		148614-0-01	A-34	
112755-0-01	E-20		140693-0-00	M- 3- 7			F-26		148615-0-01	L- 3	
112756-0-01	E-19		140890-0-01	K-12			H-12		148623-0-01	G-16	
112758-0-01	K-32		140948-0-01	M- 3- 1			J- 5		148625-0-01	G-18	
112759-0-01	D-52		140950-0-00	M- 3- 2			J-32		148628-0-01	G- 9	
112760-0-01	B-28		141331-0-01	F-35- 3		146427-0-01	B-52			G-19	
112762-0-01	K-25		141343-0-01	J-45			A-11		148629-0-01	G-11	
112763-0-01	C- 1		141439-0-01	C-27		146581-0-01	H- 8		148630-0-01	G-10	
112764-0-01	B-32		141494-0-01	C-23		146699-0-00	G-28		148631-0-01	G- 4	
113014-0-00	B- 1			F-34		147852-0-01	Z-28- 4		148632-0-01	G- 2	
113024-0-00	B-15		141748-0-01	C-47		147854-0-01	Z-28- 1		148633-0-01	G- 8	
113074-0-01	D-39		142002-0-01	Z- 8		147856-0-01	A- 6		148634-0-01	G- 6	
113362-0-01	E- 4		142443-0-01	Z- 4		147856-0-02	Z-28- 5		148635-0-01	G- 7	
113386-0-00	B-56		142711-0-01	Z-31- 3		147858-0-01	Z-28- 6		148638-0-01	C-55	
113524-0-01	K-13		142721-0-01	Z- 7		147908-0-01	Z-28		148640-0-01	C-53	
113526-0-01	K-24		142746-0-02	D-16		148005-0-01	E-51		148654-0-01	G-14	
114297-0-01	K-23		142747-0-02	D-17		148294-0-01	J-39		148662-0-01	A-17- 5	
	K-56		143548-0-00	M- 3- 9			J-42		148663-0-01	A-17- 7	
114483-0-01	Z-30		143549-0-00	M- 1-18- 1			J-49		148664-0-01	A-17- 6	
114486-0-01	K-60			M- 1-18- 4		148394-0-00	B-49		148665-0-01	A-17- 8	
114680-0-01	B-22			M- 3- 5		148480-0-01	E-18		148666-0-01	A-17- 2	
114693-0-01	B-14		143572-0-02	A- 8		148481-0-01	E-27		148667-0-01	A-17- 3	
115017-0-01	N- 3		143574-0-01	A-41		148487-0-01	D-18		148668-0-01	A-17- 4	
115177-0-01	G-13		143576-0-01	B-20		148488-0-01	D- 2		148669-0-01	A-17- 9- 3	
115249-0-01	E- 1		143581-0-01	B-50- 8		148489-0-01	D- 5		148670-0-01	A-17- 9- 1	
115558-0-02	N-14		143591-0-01	D-45		148490-0-01	D-46		148671-0-01	A-17- 9- 6	
116010-0-01	B-61		143597-0-01	D-29		148491-0-01	D-44		148708-0-01	a- 4- 4	
116283-0-01	D-55		143598-0-01	D-13		148492-0-01	D-42		148709-0-01	a- 4- 1	
116558-0-01	K-46		143609-0-01	D-21		148493-0-01	D-33		148728-0-01	E-28	
116699-0-00	B-46		143610-0-01	D-22		148494-0-01	D-41		148729-0-01	K-52	
116795-0-00	H-31		143613-0-01	D-31- 3		148495-0-01	D-37		148730-0-01	K-30	
117160-0-01	G- 5		143616-0-01	D-35		148496-0-00	D-31- 1		148731-0-00	K-29	
117466-0-00	Z-10		143625-0-01	H-26		148499-0-01	D-24		148732-0-01	K-51	
117666-0-01	G-37			H-35		148501-0-01	D-20		148733-0-01	K-37	
117685-0-01	J-29		143626-0-00	H-23		148502-0-00	E- 6			K-43	
117963-0-01	Z-31		143627-0-00	H-21		148503-0-00	E- 2		148734-0-00	K-44	
117964-0-01	Z-31-13		143635-0-00	H-34		148505-0-01	E- 7		148735-0-01	K-40	
117965-0-01	Z-31-12		143637-0-01	B-50-15		148531-0-01	F- 7		148736-0-00	K-39	
117967-0-01	Z-31- 4		143638-0-01	H-37		148535-0-01	F- 4		148737-0-01	K-41	
117968-0-01	Z-31-15		143641-0-01	H-41		148536-0-01	F- 5		148738-0-00	K-42	
117969-0-01	Z-31-16		143642-0-01	H-42		148537-0-01	F- 6		148740-0-00	K-38	
117970-0-01	Z-31- 5			a- 1- 5		148538-0-01	F-10		148741-0-01	K-36	

Parts No.	Ref. No.	Remark	Parts No.	Ref. No.	Remark	Parts No.	Ref. No.	Remark	Parts No.	Ref. No.	Remark
148742-0-00	K-35		150189-0-01	Z-33-14- 1		155880-0-01	C- 8		155966-0-01	N-41	
148743-0-01	D-28		150193-0-01	Z-33- 1		155881-0-01	C- 4		155967-0-01	N-35	
148762-0-01	K- 9		150202-0-01	Z-33- 6- 2		155882-0-01	C-10			a- 6	
148764-0-01	C-34		150553-0-01	N- 1		155883-0-01	C-46		155968-0-00	N-38	
148768-0-01	G- 1			N- 7		155884-0-01	J-20			a- 8	
148771-0-01	D-27			N-23		155886-0-01	J-20- 2		155969-0-00	N-34	
148801-0-01	D-31			N-31		155887-0-01	J-18			a- 7	
148802-0-01	D-30			N-32		155889-0-01	J-38		155970-0-01	K-25	
148804-0-01	E- 5		150553-0-03	A-10		155890-0-01	J-37		155972-0-00	K-17	
148805-0-01	A-17		150557-0-01	Z-16		155891-0-01	J-41		155973-0-00	J-58	
148821-0-01	E-13		150721-0-02	N- 6		155892-0-01	J-30		155974-0-01	M- 1	
148835-0-01	C- 5		151007-1-01	K-58		155896-0-01	J-33		155977-0-01	M- 1-18	
148882-0-01	Z-21		151021-0-01	E-29- 8		155897-0-01	J-35		155978-0-01	M- 1-18- 7	
148890-1-01	Z-18		151027-0-01	E-29- 7		155898-0-01	J-47		155979-0-01	M- 1-18-16	
149010-0-00	Z-13		151084-0-00	K-18		155899-0-01	J-43		155981-0-00	M- 3- 8	
149019-0-01	C-41		151147-0-01	M- 1-18-17		155900-0-01	J-44		156007-0-01	J-25	
149023-0-01	C-44		151508-0-01	D-15		155902-0-00	J-46		156015-0-01	C-14	
149024-0-01	C-25		151602-0-01	D- 4		155903-0-01	J-48		156020-0-00	J-36	
149025-0-01	C-24		151604-0-01	C- 2			a- 9		156021-0-00	J-17	
149027-0-01	C-21			E- 3		155904-0-01	J-50		156058-0-01	A- 4	
149030-0-01	C-30			H-20			Z-23		156093-0-01	M- 1	
149031-0-01	C-31			H-22			a-10		156096-0-00	M- 1-18-15	
149033-0-01	C-35			H-33- 2		155905-0-00	J-52		156098-0-01	M- 3	
149034-0-01	C-20		151605-0-01	B-11			Z-24		156099-0-01	M- 3	
149035-0-02	C-19			D- 1		155906-0-01	J-54		180157-0-01	B-25	
149036-0-01	F-12			D-30- 2		155907-0-01	J-12		180164-0-01	E-12	
149037-0-01	F-30			H-36		155908-0-01	J-59		180321-0-01	D-26	
149040-0-01	F-32		153008-0-01	B-50- 2		155909-0-01	J-14		180949-0-01	E-41	
149042-0-01	F-29		153009-0-01	B-50-10		155914-0-01	J-13		181712-0-01	F-19	
149043-0-01	G-26		153011-0-16	B-53			J-56		181713-0-01	F-17	
149049-0-01	G-22		153011-4-16	Z-11		155915-0-01	J- 3		181756-0-01	A-17- 9	
149050-0-01	G-17		153013-0-01	B-50-11		155916-0-01	J- 4		215080-0-01	L- 1-12	
149052-0-01	G-36		153015-0-01	H-33		155917-0-01	J-66			L- 1-20	
149055-0-01	G-32		153017-0-01	H-18		155918-0-01	J-67		215083-0-01	L- 1- 2	
149056-0-01	G-31		153019-0-01	H-40		155922-0-01	J-63			L- 1- 9	
	G-40- 5			Z-22		155923-0-01	J- 8		216323-0-01	M- 1-18- 5	
149058-0-01	G-40		153021-0-01	B-54		155924-0-01	J-61		216324-0-01	M- 1-18- 6	
149061-0-01	G-24			a- 2		155925-0-01	J-65		216382-0-01	M- 3-11	
149063-0-01	C-36		153023-0-01	H-32		155926-0-01	H-10		216384-0-01	M- 3-10	
149168-0-01	Z-31-11		153024-0-00	H-17		155927-0-01	H-44		217093-0-01	L- 1- 7	
149169-0-01	F- 9		153025-0-01	H-29		155928-0-01	H-44		218859-0-01	M- 1-16	
	Z-25		153026-0-01	H-25		155929-0-01	H-14		219557-0-00	L- 1-13	
149179-0-01	A-38		153027-0-01	H-19		155932-0-01	B-57		219558-0-00	L- 1-14	
149241-0-01	G-29		153029-0-01	H-38			a- 4		219559-0-00	L- 1-15	
149281-0-01	G-38		153168-0-01	D-14		155933-0-01	a- 4- 3		221421-0-01	L- 1-16	
149282-0-01	C-58		153243-0-01	E-32		155934-0-01	a- 4- 2		221786-0-01	M- 1-18- 3	
149283-0-00	G-35		153244-0-01	E-33		155935-0-01	B-57		222370-0-01	L- 1	
149284-0-01	F-25		153268-0-01	M- 1-18-13			a- 4		503093-0-01	K-16	
149286-0-01	F-24		153269-0-01	M- 1-18-14		155936-0-01	a- 4- 3				
149287-0-00	F-22		153274-0-01	M- 1-18- 9		155937-0-01	C-61		153970-0-01	M- 3- 4	
149288-0-01	A-33		153433-0-00	M- 1-18- 2			a- 1		155984-0-01	M- 1-18	
149554-0-01	C-50		153483-0-01	E-45		155938-0-01	a- 1- 3				
149569-0-01	E-24		153969-0-00	M- 3- 3		155939-0-01	a- 1- 1				
149570-0-01	Z- 9		153971-0-01	M- 3- 4		155942-0-01	a- 1- 4				
149697-0-01	F-35		154491-0-01	H-16		155945-0-01	a- 1- 2				
	a-11		154506-0-01	B-30		155946-0-01	D-54				
149768-0-01	C-17		154516-0-01	E-29- 6			a- 5				
149991-0-01	C-22		154517-0-01	E-29- 1		155947-0-01	N- 5				
150106-0-01	Z-33- 6		154518-0-01	E-29- 2		155948-0-01	N- 4				
150139-0-01	Z-33-14		154519-0-01	E-29- 4		155949-0-01	N-25				
150151-0-01	Z-33		154520-0-01	E-29- 3		155950-0-01	N-30				
150172-0-01	Z-33- 5		154524-0-01	E-29		155951-0-01	N-20				
150173-0-01	Z-33- 6- 1		154702-0-01	Z-29		155952-0-01	N-11				
150174-0-00	Z-33- 2		154765-0-02	M- 1- 3		155953-0-01	N- 8				
150175-0-01	Z-33-13		155872-0-01	A- 8		155954-0-01	N-17				
150179-0-01	Z-33- 7		155873-0-01	A- 1		155955-0-00	N-29				
150180-0-00	Z-33-10		155876-0-01	A-44			a-12				
150181-1-01	Z-33-14- 2		155877-0-01	B-50		155956-0-00	a-12				
150182-0-00	Z-33- 9		155878-0-01	B-50-17		155962-0-00	N-29				
150188-0-01	Z-33-20		155879-0-01	B-42		155965-0-01	N-40				

