

**bro rom**

**INDUSTRIAL MACHINES**

Str. Fabrica de Glucoza 2-4, sector 2, Bucuresti, Romania  
Tel./Fax: +01 2323.844, +01 232.969, +01 2323.87  
www.brother.ro ww.brorom.ro mail:office@brother.ro  
www.pieseschimb.masinidecusut.ro

**brother**

**TWIN-NEEDLE, NEEDLE-FEED CORNER-STITCHING MACHINE**

**DOPPELNADEL-NADELTRANSPORT-ECKENNÄHMASCHINE**

**MACHINE À AIGUILLE DOUBLE, COUTURES D'ANGLES, ENTRAÎNEMENT PAR AIGUILLE.**

**MÁQUINA DE COSER DE DOS AGUJAS CON DOBLE ALIMENTACIÓN PARA COSTURA ANGULAR**

**LT2-B835**

**PARTS BOOK**

**TEILEKATALOG**

**LIVRE DES PIECES**

**LIBRO DE REFERENCIA DE PIEZAS**

**P835402**

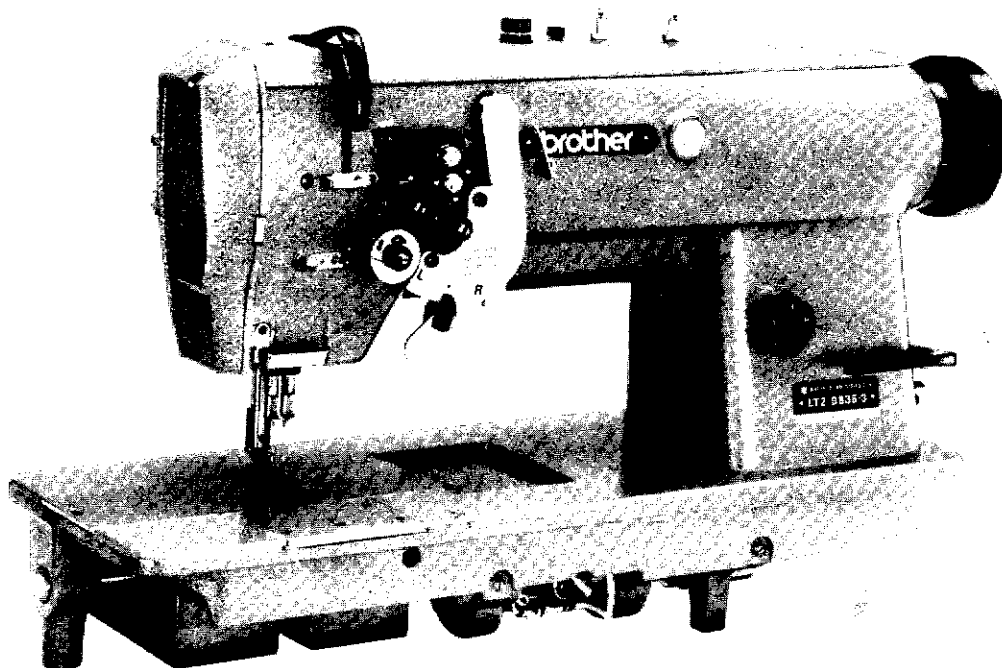

## Notes for using this parts book

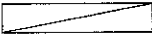
1. This book is applicable to sewing machines which have the same plate number as shown on the cover of this book (or correction sheet).
2. The symbol  in the "Parts No." column indicates that the parts is not available for supply. If, however, there is a number in the "Assembly No." column, the parts can be ordered as an assembly. Please, therefore, order by using the Assembly No.
3. This book was prepared based on information available in April, 1983.
4. Parts are subject to changes in design without prior notice.

## Anmerkungen zum Gebrauch dieses Stücklistebuches

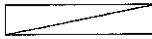
1. Dieses Buch bezieht sich auf die Nähmaschinen mit derselben Kennungsnummer wie auf diesem Buchumschlag (oder auf dem Korrekturblatt).
2. Dieses Zeichen  in der Spalte "Teilnummer" bedeutet, daß dieser Teil nicht lieferbar ist. Wenn jedoch in der Spalte "Gerätesatznummer" eine Nummer steht, kann dieser Teil als ein Geräteteilsatz bestellt werden. Bestellen Sie daher bitte mit dieser Gerätesatznummer.
3. Dieses Buch basiert auf den Informationen vom April, 1983.
4. Modelländerungen sind vorbehalten.

## Notes sur l'utilisation de ce manuel de pièces détachées

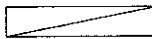
1. Ce manuel est destiné aux machines à coudre ayant le même numéro de plaque montré sur la couverture de ce manuel (ou sur la feuille de corrections).
2. Le symbole  dans la colonne "N° de pièce" signifie que la pièce ne peut être fournie. Si, dans la colonne "N° jeu de pcs", il y a un numéro de nomenclature, la pièce peut être commandée comme faisant partie d'un jeu de pièces. Donc, pour toute commande, veuillez spécifier le N° de jeu de pièces.
3. Ce manuel a été fait d'après les renseignements valables au mois de Avril, 1983.
4. Les pièces peuvent être sujettes à des modifications sans préavis.

## Notas para usar este Libro de Piezas

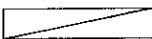
1. Este libro sirve para todas las máquinas de coser que llevan la misma placa de identificación que la que se puede ver en la tapa de este libro (o en la hoja de erratas).
2. El símbolo , que se encuentra en la columna del "Número de Pieza", quiere decir que no se dispone de dicha pieza sola. Cuando, empero, hay un número en la columna del "Numero de Juego", se podrá ordenar la pieza con todo el juego. Por lo tanto, será mejor hacer el pedido recurriendo al número del juego respectivo.
3. Este libro ha sido compilado basándose en los datos de que se disponía en abril de 1983.
4. Las piezas quedan sujetas a cambios de diseño sin aviso previo.

## CONTENTS

A. Machine body.....	1
B. Threading mechanism (1).....	2
B. Threading mechanism (2)[Standard].....	2
B. Threading mechanism (3) [-400A•-700A•-900A].....	3
C. Upper shaft mechanism .....	3
D. Needle bar rocking mechanism.....	4
E. Needle bar flip-up mechanism (1).....	5
E. Needle bar flip-up mechanism (2) [Standard•-400A•-700A] .....	5
E. Needle bar flip-up mechanism (3)[-900A]....	6
F. Presser foot mechanism (1).....	6
F. Presser foot mechanism (2) [Standard•-400A].....	7
F. Presser foot mechanism (3)[-700A•-900A]..	7
G. Feed mechanism (1).....	8
G. Feed mechanism (2)[Standard].....	8
G. Feed mechanism (3) [-400A•-700A•-900A].....	9
H. Quick reverse mechanism[-400A•-700A•-900A].....	9
J. Feed shaft mechanism.....	10
K. Rotary hook mechanism (1).....	10
K. Rotary hook mechanism (2)[Standard].....	11
K. Rotary hook mechanism (3) [-400A•-700A•-900A].....	11
L. Lower shaft mechanism.....	12
M. Lubrication (1).....	13
M. Lubrication (2)[Standard].....	14
M. Lubrication (3)[-400A•-700A•-900A].....	14
N. Thread wiper mechanism [-400A•-700A•-900A].....	15
P. Quick reverse switch mechanism [-400A•-700A•-900A].....	15
Q. Thread trimmer mechanism [-400A•-700A•-900A].....	16
R. Tension release mechanism [-400A•-700A•-900A].....	17
S. Synchronizer (1)[-400A•-700A].....	18
S. Synchronizer (2)[-900A].....	18
T. Gauge parts mechanism.....	19
U. Control box mechanism (1)[-700A BROTHER Motor] ...	20
U. Control box mechanism (2)[-900A].....	21
V. Pedal mechanism (Option parts) .....	22
Z. Accessories .....	23
Gauge parts list .....	19
INDEX.....	24

## INHALTSVERZEICHNIS

A. Maschinengehäuse.....	1
B. Fadenführungsvorrichtung (1).....	2
B. Fadenführungsvorrichtung (2)[Norm].....	2
B. Fadenführungsvorrichtung (3) [-400A•-700A•-900A].....	3
C. Obere Welle .....	3
D. Nadelstangenbetätigung.....	4
E. Nadelstangenhochstellung (1).....	5
E. Nadelstangenhochstellung (2) [Norm•-400A•-700A].....	5
E. Nadelstangenhochstellung (3)[-900A].....	6
F. Stoffdrückerfuß (1).....	6
F. Stoffdrückerfuß (2)[Norm•-400A].....	7
F. Stoffdrückerfuß (3)[-700A•-900A].....	7
G. Transportvorrichtung (1).....	8
G. Transportvorrichtung (2)[Norm].....	8
G. Transportvorrichtung (3) [-400A•-700A•-900A].....	9
H. Umkehr[-400A•-700A•-900A].....	9
J. Transport welle.....	10
K. Greifervorrichtung (1).....	10
K. Greifervorrichtung (2)[Norm].....	11
K. Greifervorrichtung (3) [-400A•-700A•-900A].....	11
L. Untere welle.....	12
M. Schmierung (1).....	13
M. Schmierung (2)[Norm].....	14
M. Schmierung (3)[-400A•-700A•-900A].....	14
N. Fadenwischvorrichtung [-400A•-700A•-900A].....	15
P. Umkehrschalter[-400A•-700A•-900A]....	15
Q. Fadenabschneidevorrichtung [-400A•-700A•-900A].....	16
R. Spannung sverminderung svorrichtung [-400A•-700A•-900A].....	17
S. Synchronisator (1)[-400A•-700A].....	18
S. Synchronisator (2)[-900A].....	18
T. Lehren .....	19
U. Schaltkasten (1)[-700A BROTHER Motor].....	20
U. Schaltkasten (2)[-900A].....	21
V. Pedal (Option parts).....	22
Z. Zubehör.....	23
Lehrenliste .....	19
VERZEICHNIS.....	24

## TABLE DES MATIERES

A. Corps de la machine .....	1
B. Mécanisme de Jénfilage (1).....	2
B. Mécanisme de Jenfilage (2)[Standard] .....	2
B. Mécanisme de Jénfilage (3) [-400A•-700A•-900A].....	3
C. Mécanisme de larbre superieur.....	3
D. Mécanisme de balancement de la barre à aiguille.....	4
E. Mécanisme de sauté de la barre à aiguille (1).....	5
E. Mécanisme de sauté de la barre à aiguille (2) [Standard•-400A•-700A].....	5
E. Mécanisme de sauté de la barre à aiguille (3) [-900A].....	6
F. Mécanisme du pied presseur (1).....	6
F. Mécanisme du pied presseur (2) [Standard•-400A].....	7
F. Mécanisme du pied Presseur (3) [-700A•-900A].....	7
G. Mécanisme de léntraînement (1).....	8
G. Mécanisme de léntraînement (2)[Standard].....	8
G. Mécanisme de léntraînement (3) [-400A•-700A•-900A].....	9
H. Mécanisme de marche arrière rapide [-400A•-700A•-900A].....	9
J. Mécanisme de l'arbre entraînement .....	10
K. Mécanisme du crochet rotatif (1).....	10
K. Mécanisme du crochet rotatif (2)[Standard]... 11	11
K. Mécanisme du crochet rotatif (3) [-400A•-700A•-900A].....	11
L. Mécanisme de l'arbre inférieur.....	12
M. Lubrification (1) .....	13
M. Lubrification (2)[Standard].....	14
M. Lubrification (3)[-400A•-700A•-900A].... 14	14
N. Mécanisme de tire-fil[-400A•-700A•-900A].... 15	15
P. Mécanisme de interrupteur de marche arrière rapide[-400A•-700A•-900A].....	15
Q. Mécanisme de coupe-fill[-400A•-700A•-900A]. 16	16
R. Mécanisme de relâche-tension [-400A•-700A•-900A].....	17
S. Synchronisateur (1)[-400A•-700A].....	18
S. Synchronisateur (2)[-900A].....	18
T. Pièces d'écartement.....	19
U. Mécanisme du boîtier de contrôle (1) [-700A BROTHER Moteur].....	20
U. Mécanisme du boîtier de contrôle (2)[-900A].... 21	21
V. Mécanisme de la pédale[Pièces en option].....	22
Z. Accessoires .....	23
Liste des pièces d'écartement.....	19
INDEX .....	24

## INDICE

A. Denominación del mecanismo .....	1
B. Mécanismo de la enhebrado (1).....	2
B. Mécanismo de la enhebrado (2)[Norma]..... 2	2
B. Mécanismo de la enhebrado (3) [-400A•-700A•-900A].....	3
C. Mécanismo de la eje superior.....	3
D. Mécanismo de oscilación de la barra de aguja..... 4	4
E. Mécanismo del lanzador de barra de aguja (1)..... 5	5
E. Mécanismo del lanzador de barra de aguja (2) [Norma•-400A•-700A].....	5
E. Mécanismo del lanzador de barra de aguja (3) [-900A].....	6
F. Mécanismo del prensa telas (1).....	6
F. Mécanismo del prensa telas (2)[Norma•-400A].... 7	7
F. Mécanismo del prensa telas (3)[-700A•-900A].... 7	7
G. Mécanismo de la alimentación (1).....	8
G. Mécanismo de la alimentación (2)[Norma].... 8	8
G. Mécanismo de la alimentación (3) [-400A•-700A•-900A].....	9
H. Mécanismo de inversión rápida [-400A•-700A•-900A].....	9
J. Mécanismo de la eje alimentación .....	10
K. Mécanismo del cangrejo (1).....	10
K. Mécanismo del cangrejo (2)[Norma].....	11
K. Mécanismo del cangrejo (3) [-400A•-700A•-900A].....	11
L. Mécanismo de la eje inferior.....	12
M. Lubricación (1).....	13
M. Lubricación (2)[Norma].....	14
M. Lubricación (3)[-400A•-700A•-900A].... 14	14
N. Mécanismo de limpiador de hilos [-400A•-700A•-900A].....	15
P. Mécanismo de conmutador de inversión rápida [-400A•-700A•-900A].....	15
Q. Mécanismo de recortadora de orillos [-400A•-700A•-900A].....	16
R. Mécanismo de liberador de tensión [-400A•-700A•-900A].....	17
S. Sincronizador (1)[-400A•-700A].....	18
S. Sincronizador (2)[-900A].....	18
T. Piezas calibradoras.....	19
U. Mécanismo del caja de controles (1) [-700A BROTHER Motor].....	20
U. Mécanismo del caja de controles (2)[-900A].... 21	21
V. Mécanismo de la pedal[Pièces opción].....	22
Z. Accesorios .....	23
Lista de piezas calibradoras.....	19
INDICE .....	24

A. Machine body / Maschinengehäuse  
 Corps de la machine / Denominación del mecanismo

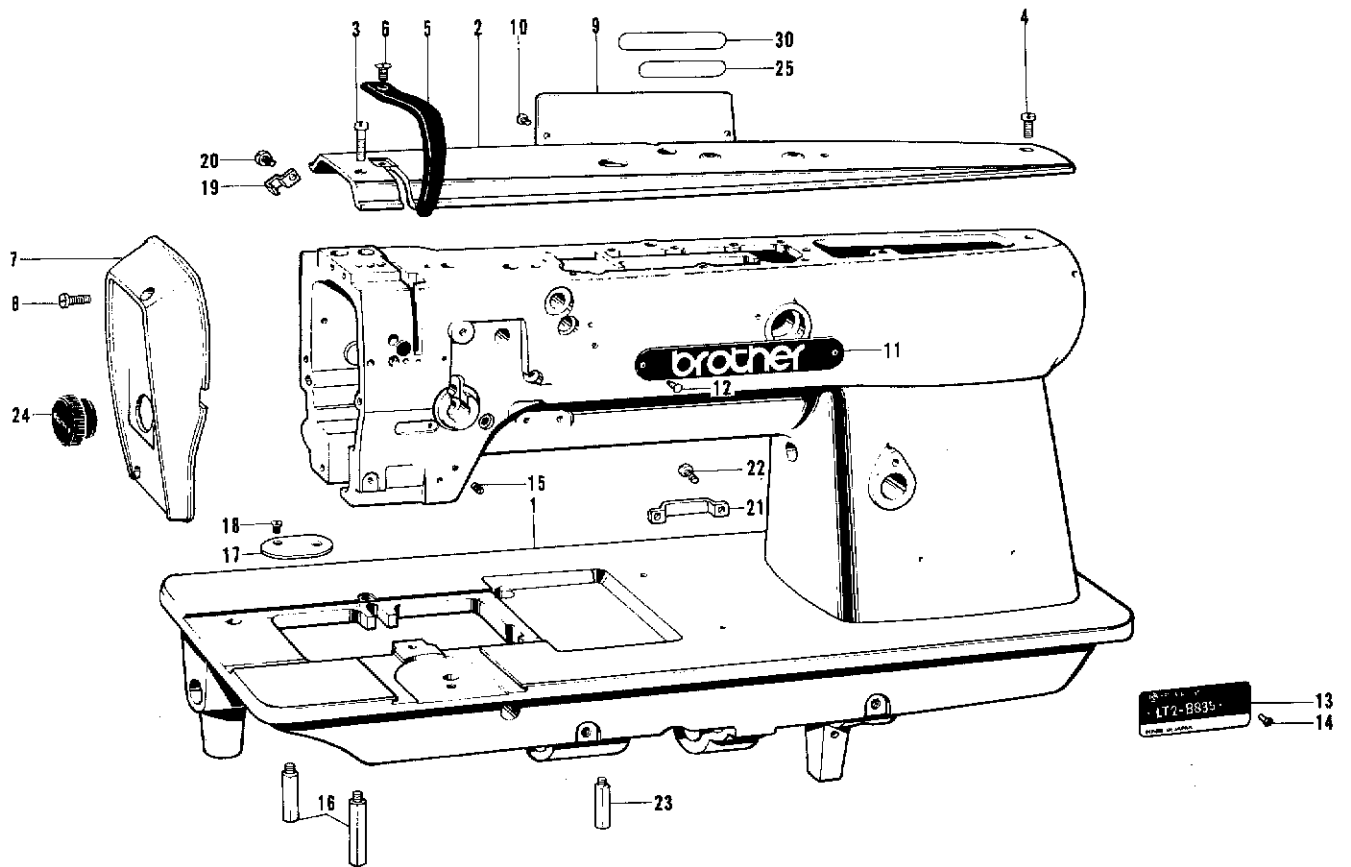

Ref. No.	Name of Parts	Q'ty	Parts No.	Assembly No.	Ref. No.	Name of Parts	Q'ty	Parts No.	Assembly No.
1	Arm Bed	1			15	Screw 4.37	2	151602-0-02	
2	Arm Top Cover	1	112560-0-03		16	Bed Leg (for Thread Trimmer)	2	148611-0-01	
3	Screw 4.37 x 16	1	009681-6-12		17	Cover (for Thread Trimmer)	1	148614-0-01	
4	Screw 4.37 x 10	1	009681-0-12		18	Screw 3.18 (for Thread Trimmer)	2	149288-0-02	
5	Thread Take-up Cover	1	112561-0-02		19	Tube Holder (L)(for Thread Trimmer)	2	142268-0-01	
6	Screw 4.76	1	107231-0-02		20	Screw 3.57 x 6 (for Thread Trimmer)	2	009670-6-12	
7	Face Plate	1	149819-0-03		21	Cord Holder (LL)(for -400A, -700A)	1	148818-0-01	
8	Screw 3.57 x 8	2	009670-8-12			Cord Holder 3 (for -900A)	2	148462-0-01	
9	Read Cover	1	112566-0-03		22	Screw 3.57 x 6	2	009670-6-12	
10	Screw 3.57 x 6	2	009670-6-12		23	Bed Leg (Small)	1	149179-0-01	
11	Name Plate	1			24	Face Plate Cap	1	150815-0-01	
12	Pin	2			25	Name Plate	1		
13	Model Plate	1			30	Parts Book Number Plate	1		
14	Pin	2							

B. Threading mechanism (1)  
 FadenführungsVorrichtung (1)  
 Mécanisme de Jénfilage (1)  
 Mécanismo de la enhebrado (1)

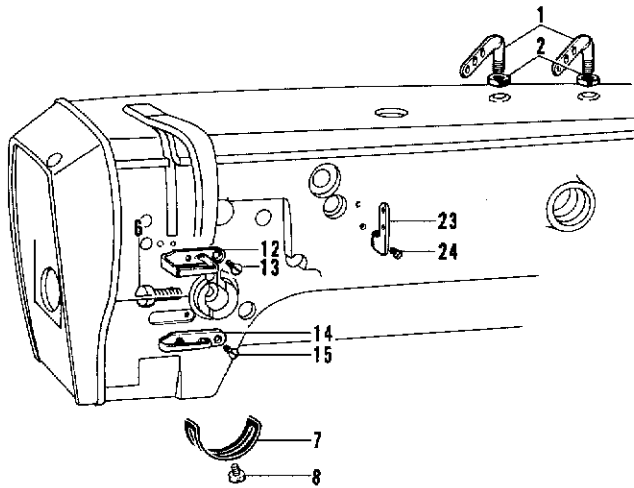

B. Threading mechanism (2)(Standard)  
 FadenführungsVorrichtung (2)(Norm)  
 Mécanisme de Jénfilage (2)(Standard)  
 Mécanismo de la enhebrado (2)(Norma)

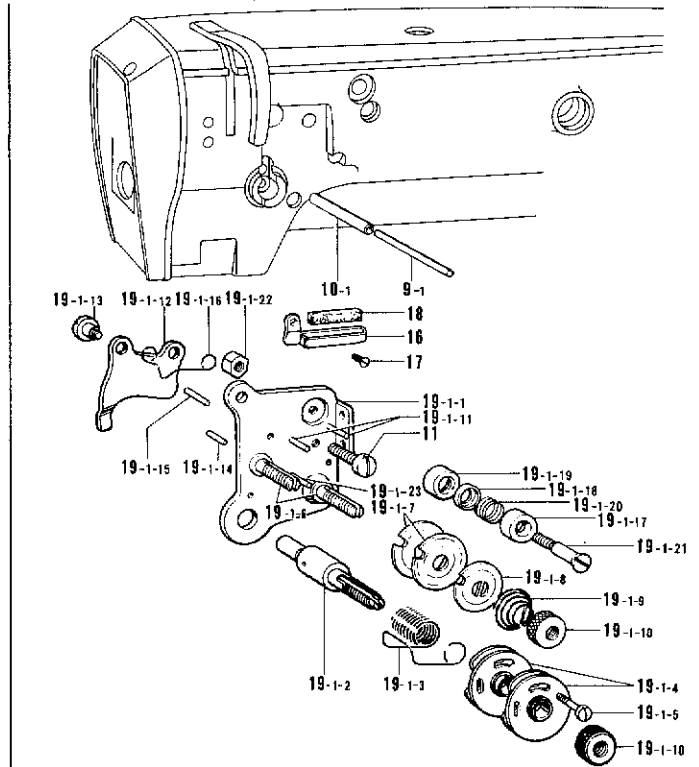

Ref. No.	Name of Parts	Q'ty	Parts No.	Assembly No.
1	Top Cover Therad Guide	2	140527-0-01	
2	Nut 5.95	2	150553-0-03	
6	Screw 3.57	1	100064-0-02	
7	Stopper	1	112709-0-01	
8	Screw 3.57 x 6	1	009670-6-12	
12	Arm Thread Guide (Upper)	1	108266-0-01	
13	Screw 3.57	1	108960-0-02	
14	Arm Thread Guide (Center)	1	112658-0-01	
15	Screw 3.57	1	108960-0-02	
23	Thread Guide (F)	1	149826-0-01	
24	Screw 3.57	1	108960-0-02	

Ref. No.	Name of Parts	Q'ty	Parts No.	Assembly No.
9-1	Tension Release Bar	1	144823-0-01	
10-1	Pipe	1	112714-0-00	
11	Screw 4.37 x 10	1	009681-0-12	
16	Arm Thread Guide (Lower)	1	112715-0-01	
17	Screw 3.57	1	108960-0-02	
18	Felt	1	114941-0-01	
19-1-1	Upper Thread Tension Plate	1		
19-1-2	Tension Stud	1	144680-0-01	
19-1-3	Thread Take-up Spring	1	144681-0-01	
19-1-4	Spring Guide Assembly	2	108254-0-01	
19-1-5	Screw 2.38	1	144682-0-01	
19-1-6	Tension Stud	2	112706-0-01	
19-1-7	Tension Disc	4	108263-0-01	
19-1-8	Tension Disc Washer	2	108264-0-01	
19-1-9	Tension Spring (for-3)	2	118317-0-01	
19-1-10	Tension Spring (for-5)	2	148924-1-01	
19-1-11	Tension Control Nut	3	108265-0-01	
19-1-12	Tension Release Plate	1	144683-0-01	
19-1-13	Stud Screw 3.57	2	112712-0-01	
19-1-14	Pin	1	144703-0-01	
19-1-15	Pin	1	144704-0-01	
19-1-16	Tension Release Spring	2	118320-0-01	
19-1-17	Cap	2	144685-0-01	
19-1-18	Disc	2	144686-0-01	
19-1-19	Thread Guide Bracket	2	144687-0-01	
19-1-20	Thread Guide Spring	2	144688-0-01	
19-1-21	Stud Screw	2	144689-0-01	
19-1-22	Nut 3.57	2	021670-1-02	
19-1-23	Pin	2		

B-19-1  
 Upper Tension  
 Control Assembly  
 (for-3)  
 144678-0-01  
 (for-5)  
 148011-1-01

**B. Threading mechanism (3)[-400A--700A--900A]**  
 Fadenführungsrichtung (3)[-400A--700A--900A]  
 Mécanisme de Jénfilage (3)[-400A--700A--900A]  
 Mécanismo de la enhebrado (3)[-400A--700A--900A]

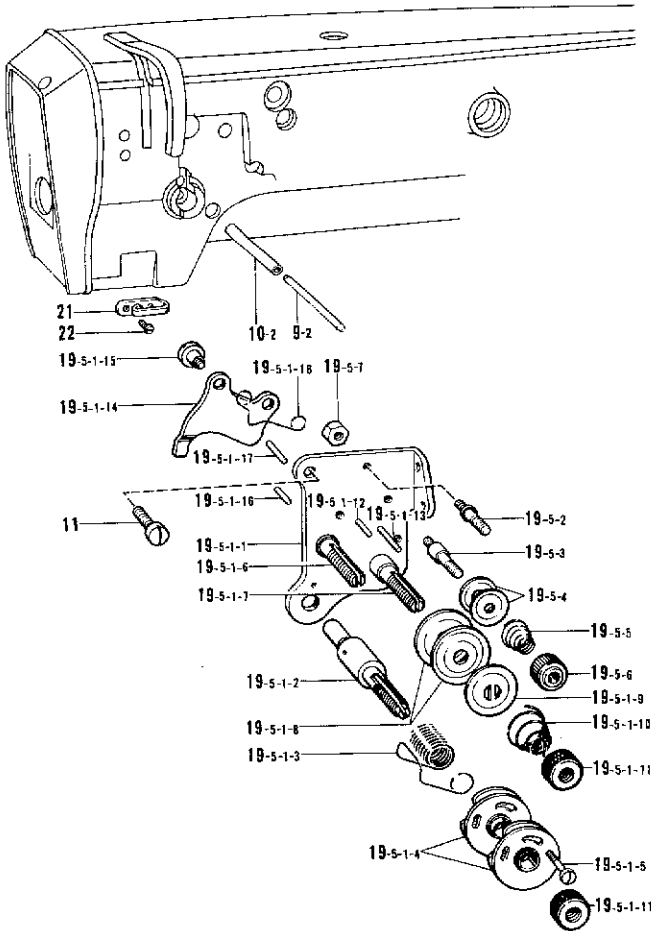

Ref. No.	Name of Parts	Q'ty	Parts No.	Assembly No.
9-2	Thread Tension Releaser	1	112713-0-01	
10-2	Pipe	1	148604-0-00	
11	Screw 4.37 x 10	1	009681-0-12	
19-5-1-1	Upper Thread Tension Plate	1		
19-5-1-2	Tension Stud	1	144680-0-01	
19-5-1-3	Thread Take-up Spring	1	155491-0-01	
19-5-1-4	Spring Guide	2	108254-0-01	
19-5-1-5	Screw 2.38	1	144682-0-01	
19-5-1-6	Tension Stud	1		
19-5-1-7	Tension Stud (R)	1		
19-5-1-8	Tension Disc	4	145446-0-01	
19-5-1-9	Presser for Tension Disc	2	159805-0-01	
19-5-1-10	Tension Spring	2	155492-0-01	
19-5-1-11	Tension Control Nut	3	108265-0-01	
19-5-1-12	Pin	1		
19-5-1-13	Pin 2.6 x 20	1		
19-5-1-14	Tension Release Plate	1	144683-0-01	
19-5-1-15	Stud Screw 3.57	2	112712-0-01	
19-5-1-16	Pin	1	144703-0-01	
19-5-1-17	Pin (R)	1	158769-0-01	
19-5-1-18	Tension Release Spring	1	118320-0-01	
19-5-2	Thread Guide Shaft (L)	1	158771-0-01	
19-5-3	Thread Guide Shaft (R)	1	158770-0-01	
19-5-4	Thread Guide Disc	4	144504-0-01	
19-5-5	Pre-Tension Spring	2	158782-1-01	
19-5-6	Nut	2	155510-0-01	
19-5-7	Nut 3.57	2	021670-1-02	
21	Arm Thread Guide (Center)	1	112658-0-01	
22	Screw 3.57	1	108960-0-02	

B-19-5  
 Upper Tension  
 Control Assembly  
 158764-1-01

**C. Upper shaft mechanism**  
 Obere welle  
 Mécanisme de l'arbre superieur  
 Mécanismo de la eje superior

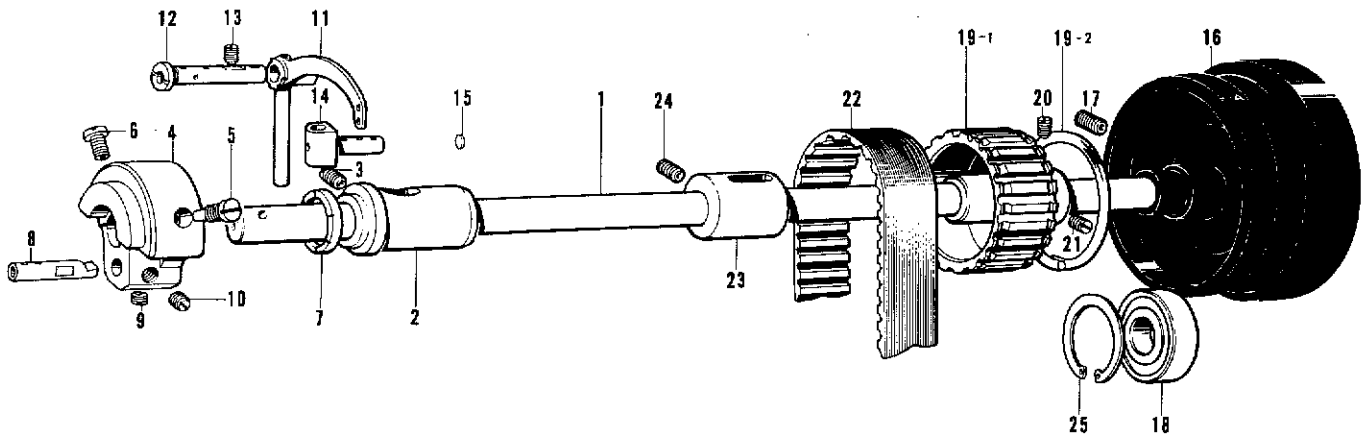

Ref. No.	Name of Parts	Q'ty	Parts No.	Assembly No.	Ref. No.	Name of Parts	Q'ty	Parts No.	Assembly No.
1	Upper Shaft	1	112572-0-01		15	Pusher	1	113024-0-00	
2	Upper Shaft Bushing (Left)	1	112573-0-01		16	Pulley (for Standard)	1	144614-0-01	
3	Screw 5.95	1	013761-4-10		17	Pulley (for Thread Trimmer)	1	158749-0-01	
4	Counter Weight	1	149820-0-00		18	Bearing 6204 VV	1	072620-4-60	
5	Screw 7.14	1	100250-0-01		19-1	Timing Belt Wheel (Upper)	1		
6	Screw 7.14	1	146141-0-01		19-2	Side Ring	2		
7	Thrust Ring	1	112576-0-01		20	Screw 6.35 x 12	1	015771-2-12	
8	Needle Bar Crank	1	149821-0-01		21	Screw 6.35 x 12	1	013771-2-12	
9	Screw 6.35	1	101706-0-01		22	Timing Belt	1	112586-0-01	
10	Screw 6.35	1	100251-0-01		23	Upper Shaft Bushing (Center)	1	114680-0-01	
11	Thread Take-up (for Standard)	1	149823-0-01		24	Screw 5.95	1	013761-4-10	
	Thread Take-up (for Thread Trimmer)	1	S00314-0-01		25	Stop Ring (C)	1	112760-0-01	
12	Stud	1	149824-0-01						
13	Screw 5.95	1	013761-4-10						
14	Thread Take-up Lever Slide Block	1	149825-0-01						

C-19  
 Timing Belt Wheel  
 Upper Assembly  
 180157-0-01



E. Needle bar flip-up mechanism (1)  
 Nadelstangenhochstellung (1)  
 Mécanisme de sautée de la barre à aiguille (1)  
 Mecanismo del lanzador de barra de aguja (1)

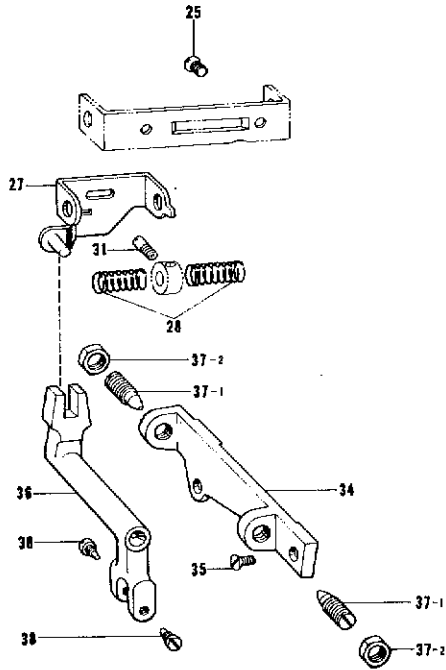

Ref. No.	Name of Parts	Q'ty	Parts No.	Assembly No.
25	Screw 4.37	2	107272-0-02	
27	Slide Shaft Support Bracket Assembly	1	149860-0-01	
28	Spring	2	149863-0-01	
31	Guide Screw	1	149865-0-01	
34	Rock Crank Shaft Supporter	1	149867-0-01	
35	Screw 4.37	2	107272-0-02	
36	Rock Crank	1	149868-0-01	
37-1	Taper Screw (Right) 7.14	2		E-37 Taper Screw Assembly 115638-0-0-4
37-2	Nut 7.14	2		
38	Screw	2	100043-0-03	

E. Needle bar flip-up mechanism (2) (Standard-400A-700A)  
 Nadelstangenhochstellung (2) (Norm-400A-700A)  
 Mécanisme de sautée de la barre à aiguille (2) (Standard-400A-700A)  
 Mecanismo del lanzador de barra de aguja (2) (Norma-400A-700A)

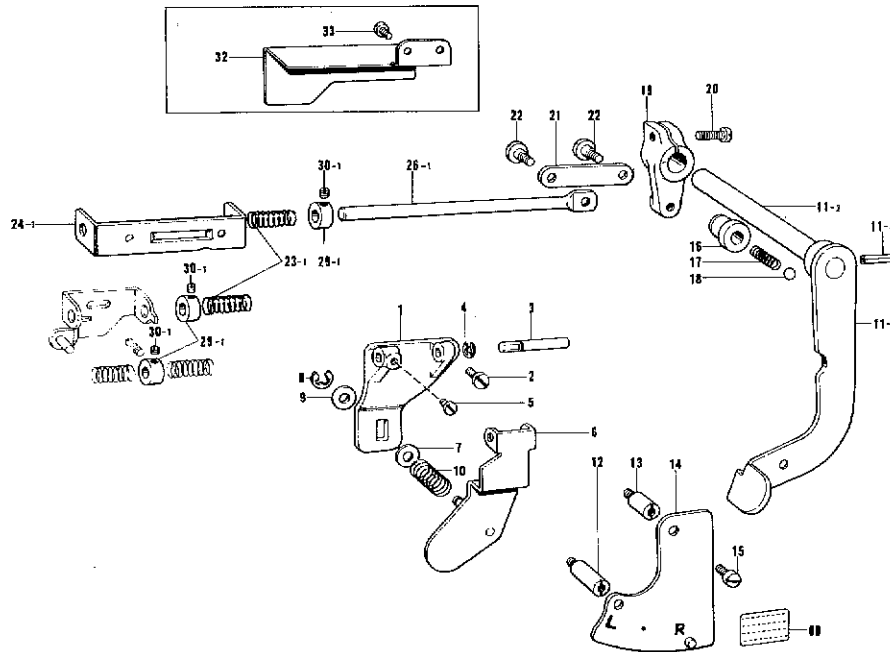

Ref. No.	Name of Parts	Q'ty	Parts No.	Assembly No.	Ref. No.	Name of Parts	Q'ty	Parts No.	Assembly No.
1	Push Lever Bracket	1	149837-0-01		15	Screw 4.76 x 8	2	009710-8-12	
2	Screw 4.76 x 10	2	009711-0-12		16	Joint Guide Bushing	1	150819-0-01	
3	Stud 5 x 32	1	149838-0-01		17	Spring	1	150820-0-01	
4	Stop Ring E4	1	048040-3-42		18	Steel Ball 1/4	1	071063-5-50	
5	Screw 3.57	1	009670-5-12		19	Lever Shaft Arm	1	149855-0-01	
6	Push Lever Assembly	1	149839-0-01		20	Screw 4.76 x 14	1	009711-4-12	
7	Washer 4.76	1	025710-2-32		21	Lever Shaft Arm Link	1	149856-0-01	
8	Stop Ring E3	1	048030-3-42		22	Screw 4.37	2	146597-1-01	
9	Washer 4.76	1	025710-2-32		23-1	Spring	2	149857-0-01	
10	Spring	1	149843-0-01		24-1	Slide Shaft Supporter	1	149858-0-01	
11-1	Stop Lever	1		E-11 Stop Lever Shaft Assembly 149847-0-01	26-1	Slide Shaft	1	149859-0-01	
11-2	Stop Lever Shaft	1			29-1	Set Collar	3	149864-0-01	
11-3	Spring Pin AW3	1	047301-8-42		30-1	Screw 3.57	5	011679-3-12	
12	Stud (L)	1	149852-0-01		32	Slide Shaft Cover (for Standard)	1	149866-0-02	
13	Stud (S)	1	149853-0-01		33	Screw 3.57 x 6 (for Standard)	2	009670-6-12	
14	Flip-up Holder Plate Assembly	1	150818-0-01		60	Label	1		

E. Needle bar flip-up mechanism (3)[-900A]  
 Nadelstangenhochstellung (3)[-900A]  
 Mécanisme de sautée de la barre à aiguille (3)[-900A]  
 Mecanismo del lanzador de barra de aguja (3)[-900A]

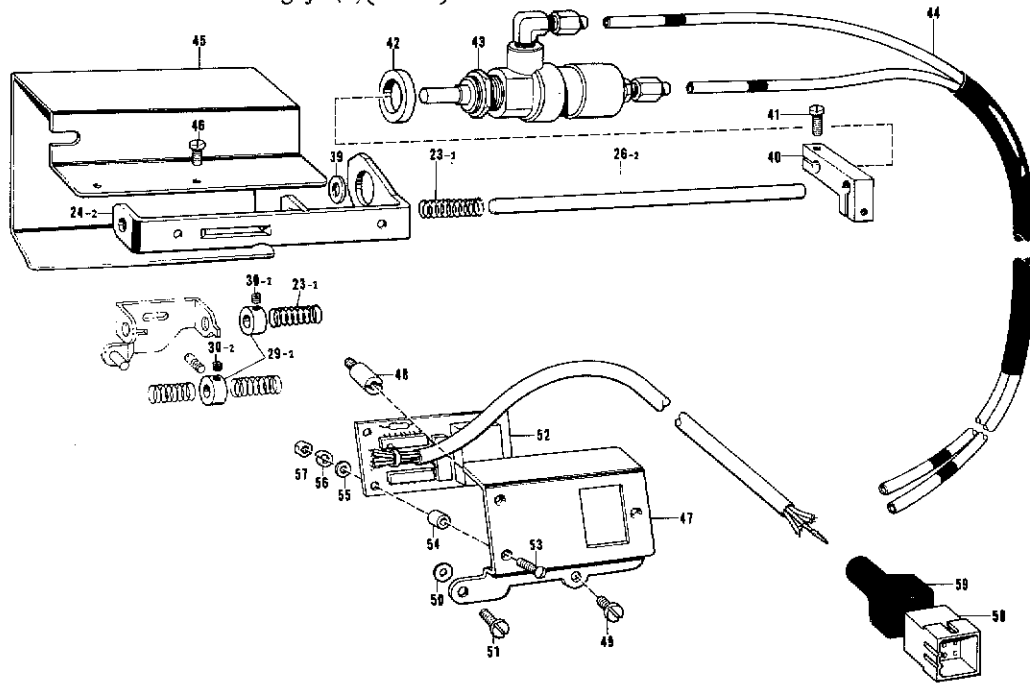

Ref. No.	Name of Parts	Q'ty	Parts No.	Assembly No.	Ref. No.	Name of Parts	Q'ty	Parts No.	Assembly No.
23-2	Spring	2	153066-0-01		47	Led Mount	1	154498-1-01	
24-2	Slide Shaft Supporter	1	153064-0-01		48	Stud (S)	1	149853-0-01	
26-2	Slide Shaft	1	153065-0-01		49	Screw 4.76 x 8	1	009710-8-12	
29-2	Set Color	2	149864-0-01		50	Washer	1	110735-0-01	
30-2	Screw 3.57	3	011679-3-12		51	Screw 4.37 x 12	1	009681-2-12	
39	Washer	2	118735-0-01		52	Led Circuit Board	1	S00315-0-01	
40	Joint	1	153067-0-01		53	Screw 3.57 x 14	3	151626-0-01	
41	Screw 3.57 x 10	2	009671-0-12		54	Spacer	3	154514-0-01	
42	Spacer	1	153068-0-01		55	Washer	3	105248-0-03	
43	Cylinder Assembly	1	153069-0-01		56	Washer 2-3.5	3	028350-2-42	
44	Air Tube Assembly	1	154491-0-01		57	Nut 3.57	3	021670-1-02	
45	Cylinder Cover	1	153073-0-02		58	Nylon Connector 12P	1	153969-0-00	
46	Screw 4.37 x 7	2	009680-7-12		59	Connector Cap 5	1	153971-0-01	

F. Presser foot mechanism (1)  
 Stoffdrückerfuß (1)  
 Mécanisme du pied presseur (1)  
 Mecanismo del prensa telas (1)

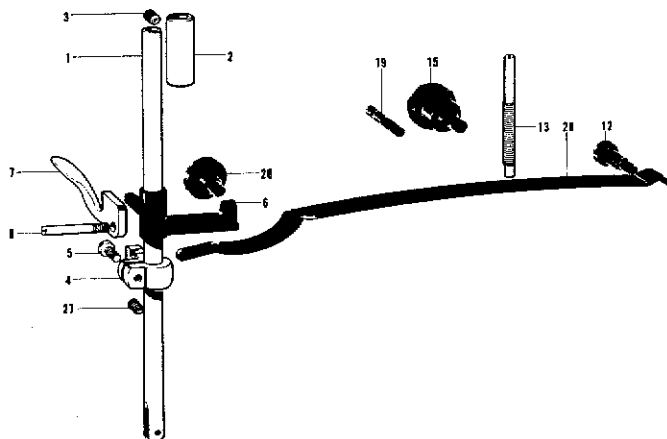

Ref. No.	Name of Parts	Q'ty	Parts No.	Assembly No.
1	Presser Bar	1	112614-0-01	
2	Presser Bar Bushing (Upper)	1	112615-0-01	
3	Screw 5.95	1	013760-6-10	
4	Presser Bar Bracket	1	112616-0-01	
5	Screw 3.57 x 8	1	009670-8-12	
6	Presser Bar Lifter	1	148483-0-01	
7	Presser Foot Lifter	1	112618-0-01	
8	Screw	1	112619-0-01	
12	Stud Screw 6.35	1	112623-0-01	
13	Presser Adjusting Screw	1	112624-0-01	
15	Stud Screw 6.35	1	112626-0-01	
19	Stopper Screw	1	112630-0-01	
20	Screw	1	112631-0-01	
27	Screw 5.95	1	151605-0-01	
28	Presser Plate Spring	1	118170-1-01	

F. Presser foot mechanism (2) [Standard-400A]  
 Stoffdrückerfuß (2) [Norm-400A]  
 Mécanisme du pied presseur (2) [Standard-400A]  
 Mecanismo del prensa telas (2) [Norma-400A]

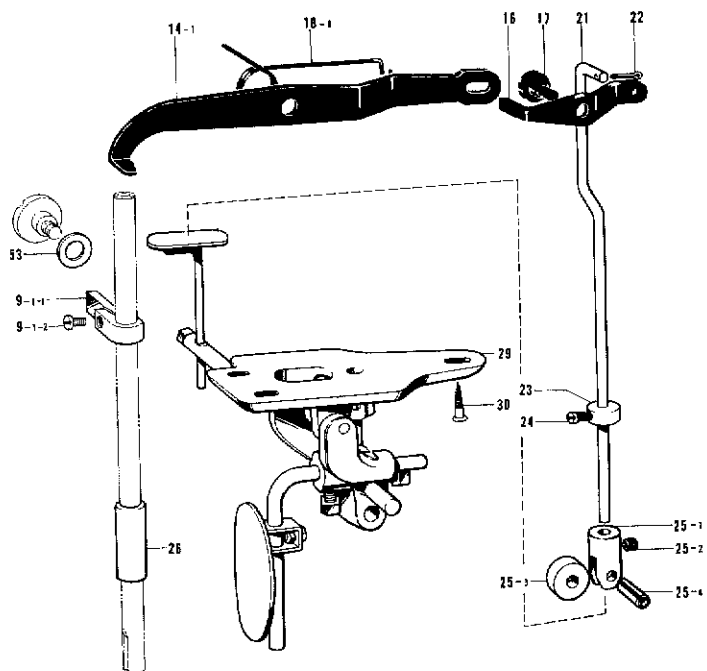

F. Presser foot mechanism (3) [-700A-900A]  
 Stoffdrückerfuß (3) [-700A-900A]  
 Mécanisme du pied Presseur (3) [-700A-900A]  
 Mecanismo del prensa telas (3) [-700A-900A]

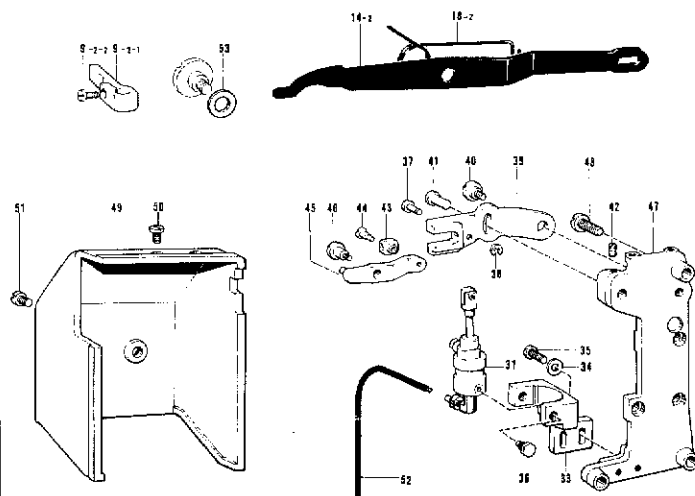

Ref. No.	Name of Parts	Q'ty	Parts No.	Assembly No.
9-1-1	Presser Bar Guide	1		F-9-1 Presser Bar Guide Assembly (for Standard) 180950-0-01 (for 400A) 148835-0-01
9-1-2	Screw 4.37 x 7	1	009680-7-12	
14-1	Knee Lifter Connecting Lever (for Standard)	1	112625-0-01	
	Knee Lifter Connecting Lever (for-400A)	1	148486-0-01	
16	Knee Lifter Lever	1	155505-0-01	
17	Stud Screw 6.35	1	112628-0-01	
18-1	Spring	1	112629-0-01	
21	Knee Lifter Connecting Rod	1	155447-1-01	
22	Pin	1	114909-0-00	
23	Set Collar	1	159436-0-01	
24	Screw 4.37	1	104908-0-04	
25-1	Roller Bracket	1		F-25 Knee Lifter Roller Assembly 156824-0-01
25-2	Screw 4.37	1	151601-0-02	
25-3	Roller	1	112636-0-01	
25-4	Spring Pin AW5	1	047501-2-42	
26	Presser Bar Bushing (Lower)	1	112763-0-01	
29	Knee Lifter Assembly (for Standard)	1	113380-0-01	
	Knee Lifter Assembly (for-400A)	1	148674-0-01	
30	Screw 6.2 x 32	3	106030-0-01	
53	Collar (for-400A)	1	148605-0-01	

Ref. No.	Name of Parts	Q'ty	Parts No.	Assembly No.
9-2-1	Presser Bar Guide	1		F-9-2 Presser Bar Guide Assembly 148835-0-01
9-2-2	Screw 4.37 x 7	1	009680-7-12	
14-2	Knee Lifter Connecting Lever	1	148486-0-01	
18-2	Spring	1	149768-0-01	
31	Presser Foot Lifter Cylinder (for-700A,900A)	1	159621-0-01	
33	Cylinder Supporter	1	159605-0-01	
34	Washer 4.76	2	025710-2-32	
35	Screw 4.76 x 16	2	009711-6-12	
36	Screw	2	140620-0-01	
37	Pin	1	146153-0-01	
38	Stop Ring E4	1	048040-3-42	
39	Presser Foot Lifter Lever	1	149024-0-01	
40	Stud Screw 6.35	1	141439-0-01	
41	Pin	1	118713-0-01	
42	Screw 4.76	1	013710-7-12	
43	Slide Block Assembly	1	149025-0-01	
44	Screw	1	141494-0-01	
45	Lever Assembly	1	149027-0-01	
46	Screw 6.35	1	149991-0-01	
47	Cylinder Base	1	159606-0-01	
48	Screw 6.35 x 14	3	009782-5-12	
49	Cylinder Cover	1	159607-0-01	
50	Screw 4.76 x 8	2	009710-8-12	
51	Screw 5 x 6	1	007500-6-02	
52	Air Tube	1	159608-0-01	
53	Collar	1	148605-0-01	

G. Feed mechanism (1)  
 Transportvorrichtung (1)  
 Mécanisme de l'entraînement (1)  
 Mecanismo de la alimentación (1)

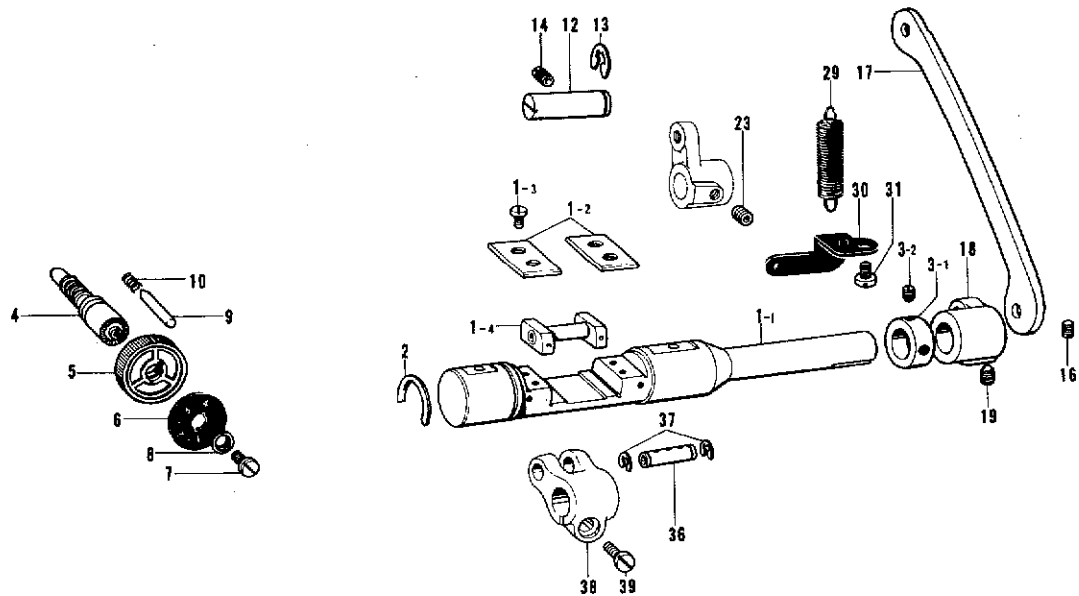

Ref. No.	Name of Parts	Q'ty	Parts No.	Assembly No.	Ref. No.	Name of Parts	Q'ty	Parts No.	Assembly No.
1-1	Feed Regulator Shaft	1		G-1	13	Stop Ring E7	1	048070-3-42	
1-2	Slide Block Guide Plate	2	143594-0-01	Feed Regulator	14	Screw 5.95	1	013761-4-10	
1-3	Screw 4.37 x 10	4	009681-0-12	Shaft Assembly	16	Screw 4.37	2	151602-0-01	
1-4	Slide Block Assembly	1	145328-0-01	148771-0-01	17	Feed Regulator Connecting Link	1	148487-0-01	
2	Stop Ring	1	143597-0-01		18	Feed Regulator Arm	1	148500-0-01	
3-1	Collar	1		G-3	19	Screw 5.95	1	118853-0-01	
3-2	Screw 6.35	2	101706-0-01	Collar Assembly	23	Screw 5.95	1	118853-0-01	
4	Length Control Screw	1	159361-0-01	180321-0-01	29	Spring	1	143609-0-01	
5	Length Control Dial	1	153168-0-01		30	Spring Hook Plate	1	143610-0-01	
6	Length Control Plate	1	151507-0-01		31	Screw 4.76 x 8	1	009710-8-12	
7	Screw 4.76	1	142747-0-02		36	Stud	1	143616-0-01	
8	Washer	1	142746-0-02		37	Stop Ring E6	2	048060-3-42	
9	Pin	1	145502-0-01		38	Lever Feed Arm	1	148495-0-01	
10	Notch Spring	1	100328-0-01		39	Screw 6.35 x 18	1	009781-8-12	
12	Feed Regulator Stud	1	148488-0-01						

G. Feed mechanism (2)[Standard]  
 Transportvorrichtung (2)[Norm]  
 Mécanisme de l'entraînement (2)[Standard]  
 Mecanismo de la alimentación (2)[Norma]

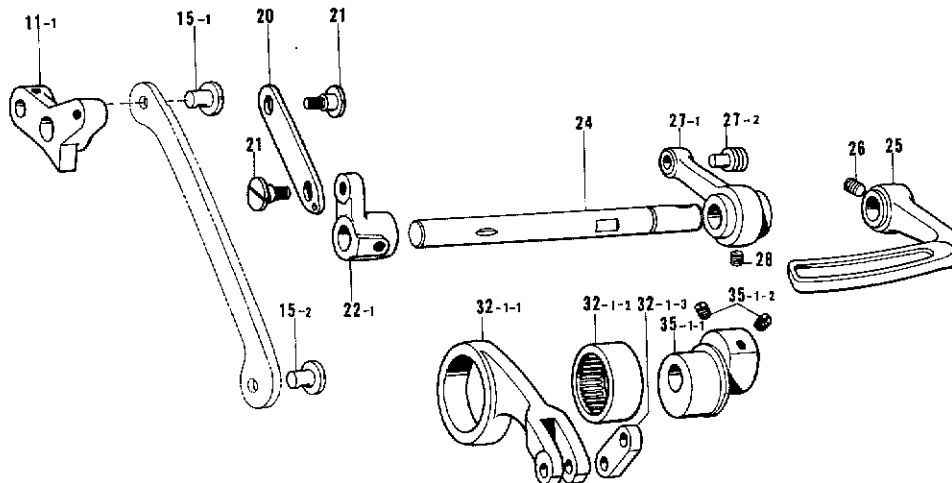

Ref. No.	Name of Parts	Q'ty	Parts No.	Assembly No.	Ref. No.	Name of Parts	Q'ty	Parts No.	Assembly No.
11-1	Feed Regulator	1	148489-0-01		27-1	Link (B)	1		G-27
15-1	Pin	1	118713-0-01		27-2	Spring Hook	1	108546-0-01	Link Assembly
15-2	Pin	1	148501-1-01		28	Screw 5.95 x 6	1	014760-6-22	143608-0-01
20	Connecting Plate	1	118746-0-01		32-1-1	Level Feed Connecting Rod	1	143612-0-00	G-32-1
21	Stud Screw 4.37	2	112072-0-01		32-1-2	Needle Bearing	1	118954-0-00	Level Feed
22-1	Lever	1	118747-0-01		32-1-3	Level Feed Connecting Linh. k	1	143613-0-01	Connection
24	Feed Regulator Lever Shaft	1	151080-0-01		35-1-1	Eccentric Wheel	1		Rod Assembly
25	Reverse Lever	1	118752-0-03		35-1-2	Screw 5.95	2	151605-0-01	143611-0-01
26	Screw 6.35 x 10	1	015771-0-12						G-35-1

**G. Feed mechanism (3)[-400A.-700A.-900A]**  
 Transportvorrichtung (3)[-400A.-700A.-900A]  
 Mécanisme de l'entraînement (3)[-400A.-700A.-900A]  
 Mecanismo de la alimentación (3)[-400A.-700A.-900A]

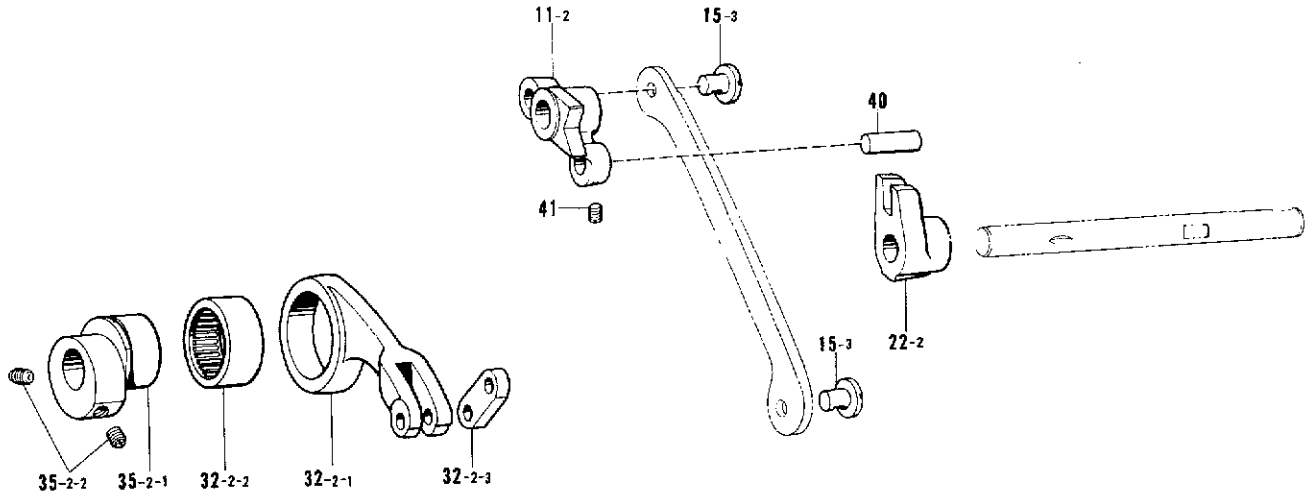

Ref. No.	Name of Parts	Q'ty	Parts No.	Assembly No.	Ref. No.	Name of Parts	Q'ty	Parts No.	Assembly No.
11-2	Feed Regulator	1	158747-0-01		35-2-1	Eccentric Wheel	1		G-35-2 Eccentric Wheel Assembly 155451-G-01
15-3	Pin	2	148501-1-01		35-2-2	Screw 5.95	2	151605-0-01	
22-2	Lever	1	158748-0-01		40	Link Stud	1	156956-0-01	
32-2-1	Level Feed Connecting Rod	1	148496-0-00	G-32-2	41	Screw 4.37	1	151602-0-01	
32-2-2	Needle Bearing	1	118954-0-00	Level Feed Connecting Rod Assembly 148801-0-01					
32-2-3	Level Feed Connecting Link	1	143613-0-01						

**H. Quick reverse mechanism[-400A.-700A.-900A]**  
 Umkehr[-400A.-700A.-900A]  
 Mécanisme de marche arrière rapide[-400A.-700A.-900A]  
 Mecanismo de inversión rápida[-400A.-700A.-900A]

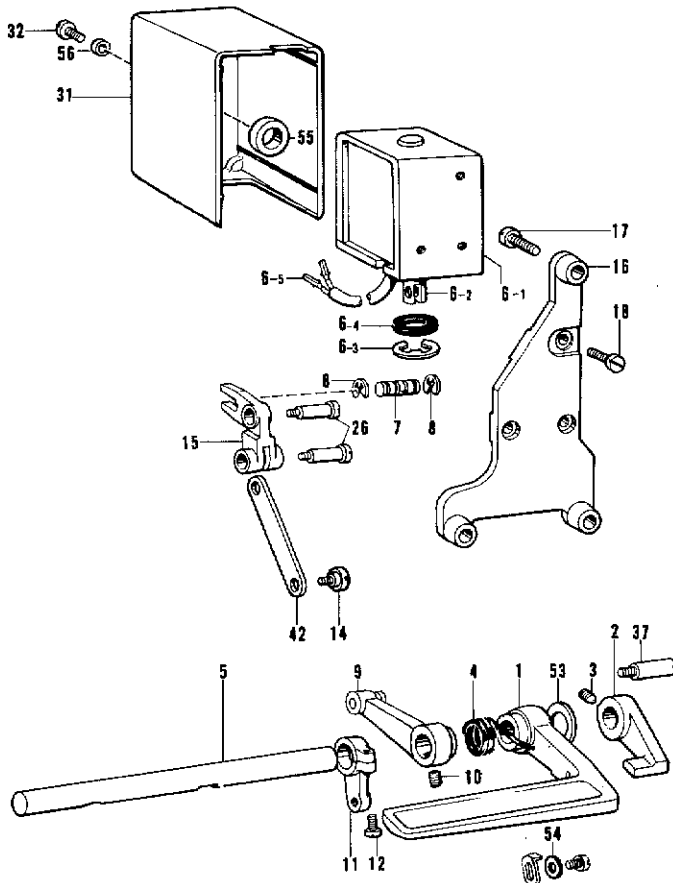

Ref. No.	Name of Parts	Q'ty	Parts No.	Assembly No.
1	Reverse Lever	1	156362-0-01	
2	Reverse Lever (B)	1	148607-0-02	
3	Screw 6.35 x 10	1	015771-0-12	
4	Spring	1	148608-0-01	
5	Reverse Lever Shaft	1	159429-0-01	
6-1	Solenoid	1		H-6 Reverse Solenoid Assembly (for EFKA Motor) 154734-0-01 (for Brother Motor) 159902-0-01 (for-900A) 154732-0-01
6-2	Plunger	1	154729-0-01	
6-3	Stop Ring E15	1	154730-0-01	
6-4	Rubber Stopper	1	154731-0-00	
6-5	Terminal Pin (for-900A, Brother Motor)	2	143549-0-00	
7	Pin	1	149174-0-01	
8	Stop Ring E4	2	048040-3-42	
9	Feed Regulator Link	1	148638-0-01	
10	Screw 5.95 x 6	1	014760-6-22	
11	Reverse Lever Shaft Arm	1	148640-0-01	
12	Screw 4.76 x 14	1	009711-4-12	
14	Stud Screw 4.76	1	110171-0-01	
15	Reverse Crank	1	158753-0-01	
16	Reverse Solenoid Bracket (for-400A)	1	158752-0-01	
17	Screw 6.35 x 25 (for-400A)	3	009782-5-12	
18	Screw 5 x 8	3	007500-8-02	
26	Stud Screw 4.76	2	148764-0-01	
31	Solenoid Cover (for-400A)	1	146105-0-00	
32	Screw 5 x 6 (for-400A)	1	007500-6-02	
37	Screw	1	141748-0-01	
42	Reverse Link	1	149063-0-01	
53	Thrust Ring	1	149554-0-01	
54	Washer	1	100645-0-03	
55	Solenoid Rubber	1	S01327-0-01	
56	Collar	1	S01328-0-01	



K. Rotary hook mechanism (2)[Standard]  
 Greifervorrichtung (2)[Norm]  
 Mécanisme du crochet rotatif (2)[Standard]  
 Mécanismo del cangrejo (2)[Norma]

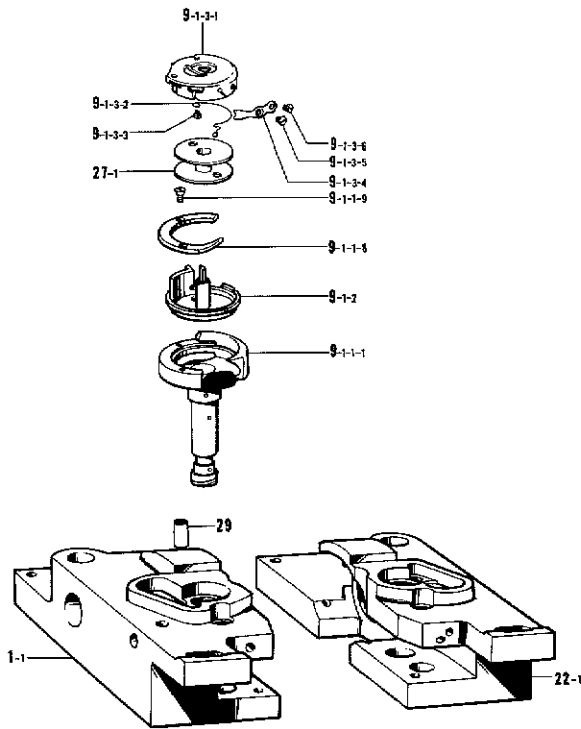

Ref. No.	Name of Parts	Q'ty	Parts No.	Assembly No.
1-1	Rotary Hook Base (Left)	1	112685-0-01	
9-1-1-1	Outer Rotary Hook	2		K-9-1-1 Outer Rotary Hook Assembly 151039-0-01
9-1-1-8	Inner Rotary Hook Presser	2		
9-1-1-9	Screw	4	151027-0-01	
9-1-2	Inner Rotary Hook Assembly	2	151040-0-01	K-9-1-2 Rotary Hook Assembly 150371-0-01
9-1-3-1	Cap	2		
9-1-3-2	Spring	2	151034-0-01	
9-1-3-3	Screw	2	151035-0-01	
9-1-3-4	Tension Adjusting Spring	2	151025-0-01	
9-1-3-5	Tension Adjusting Screw	2	S01567-0-01	
9-1-3-6	Screw	2	S01568-0-01	
22-1	Rotary Hook Base (Right)	1	112701-0-01	
27-1	Bobbin	2	112781-0-01	
29	Oil Pipe	2	115287-0-00	

K. Rotary hook mechanism (3)[-400A-700A-900A]  
 Greifervorrichtung (3)[-400A-700A-900A]  
 Mécanisme du crochet rotatif (3)[-400A-700A-900A]  
 Mécanismo del cangrejo (3)[-400A-700A-900A]

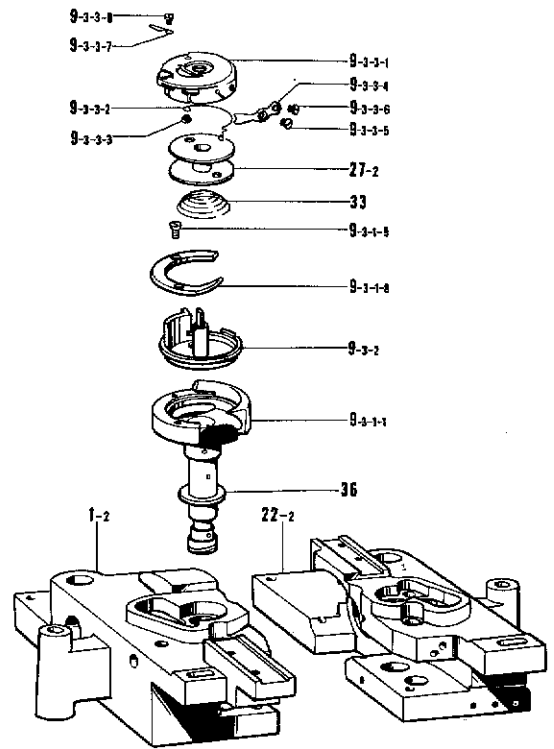

Ref. No.	Name of Parts	Q'ty	Parts No.	Assembly No.
1-2	Rotary Hook Base (Left)	1	148481-0-01	
9-3-1-1	Outer Rotary Hook	2		K-9-3-1 Outer Rotary Hook Assembly S00880-0-01
9-3-1-8	Inner Rotary Hook Presser	2		
9-3-1-9	Screw	4	151027-0-01	
9-3-2	Inner Rotary Hook Assembly	2	151042-0-01	K-9-3-2 Rotary Hook Assembly 158761-0-01
9-3-3-1	Cap	2		
9-3-3-2	Spring	2	151034-0-01	
9-3-3-3	Screw	2	151035-0-01	
9-3-3-4	Tension Adjusting Spring	2	151043-0-01	
9-3-3-5	Tension Adjusting Screw	2	S01567-0-01	
9-3-3-6	Screw	2	S01568-0-01	
9-3-3-7	Wire	2	159801-0-01	
9-3-3-8	Screw 1.59 x 2	2	159802-0-01	
22-2	Rotary Hook Base (Right)	1	148480-0-01	
27-2	Bobbin	2	148603-0-01	
33	Bobbin Tension Spring	2	148601-0-01	
36	Specer 0.3		153244-0-01	
	Specer 0.2		153243-0-01	

L. Lower shaft mechanism / Untere welle  
 Mécanisme de l'arbre inférieur / Mecanismo de la eje inferior

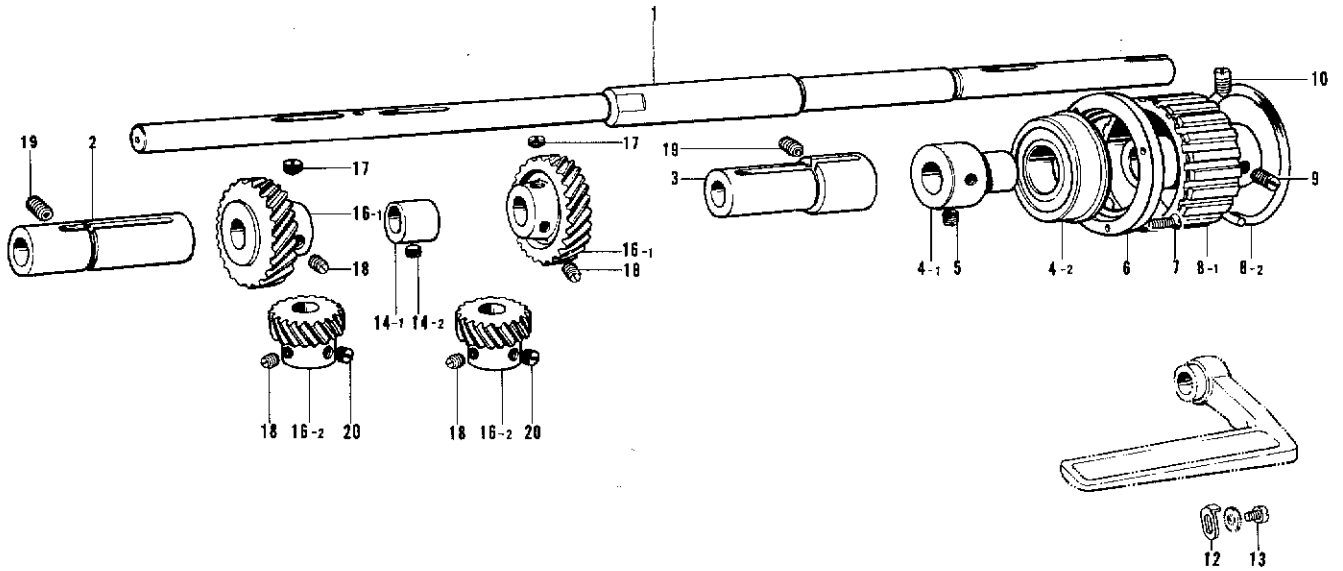

Ref. No.	Name of Parts	Q'ty	Parts No.	Assembly No.	Ref. No.	Name of Parts	Q'ty	Parts No.	Assembly No.
1	Lower Shaft (for Standard)	1	151082-0-01		10	Screw 6.35 x 12 (for Standard)	1	015771-2-12	
	Lower Shaft (for Thread Trimmer)	1	158750-0-01			Screw 6.35 (for Thread Trimmer)	1	148821-0-01	
2	Rotary Hook Base Bushing (Left)	1	148503-0-00		12	Reverse Lever Stopper	1	118865-0-01	
3	Rotary Hook Base Bushing (Right)	1	148502-0-00		13	Screw 4.37 x 7	1	009680-7-12	
4-1	Bearing Holder	1	112666-0-00	L-4 Bearing Holder Assembly 112698-0-01	14-1	Vertical Feed Eccentric Wheel	1	/	L-14 Vertical Feed Eccentric Wheel Assembly (for Standard) 181486-0-01 (for Thread Trimmer) 148804-0-01
4-2	Bushing	1	112667-0-01		14-2	Screw 6.35	1		
5	Screw 6.35 x 7	2	013780-7-10		16-1	Spiral Gear	2	/	L-16 Spiral Gear Assembly 150949-0-01
6	Presser	1	112668-0-01	16-2	Pinion	2	112684-0-01		
7	Screw 3.57 x 12	3	005671-2-12		17	Screw 6.35	2	112684-0-01	
8-1	Timing Belt Wheel Lower	1	/	L-8 Timing Belt Wheel Lower Assembly (for Standard) 180164-0-01 (for Thread Trimmer) 148803-0-01	18	Screw 6.35	4	100251-0-01	
8-2	Side Ring	1	/		19	Screw 5.95	2	151605-0-01	
9	Screw 6.35 x 12 (for Standard)	1	013771-2-12		20	Screw 6.35	6	101706-0-01	
	Screw 6.35 x 12 (for Thread Trimmer)	2	013771-2-12						

M. Lubrication (1) / Schmierung (1)  
Lubrication (1) / Lubricación (1)

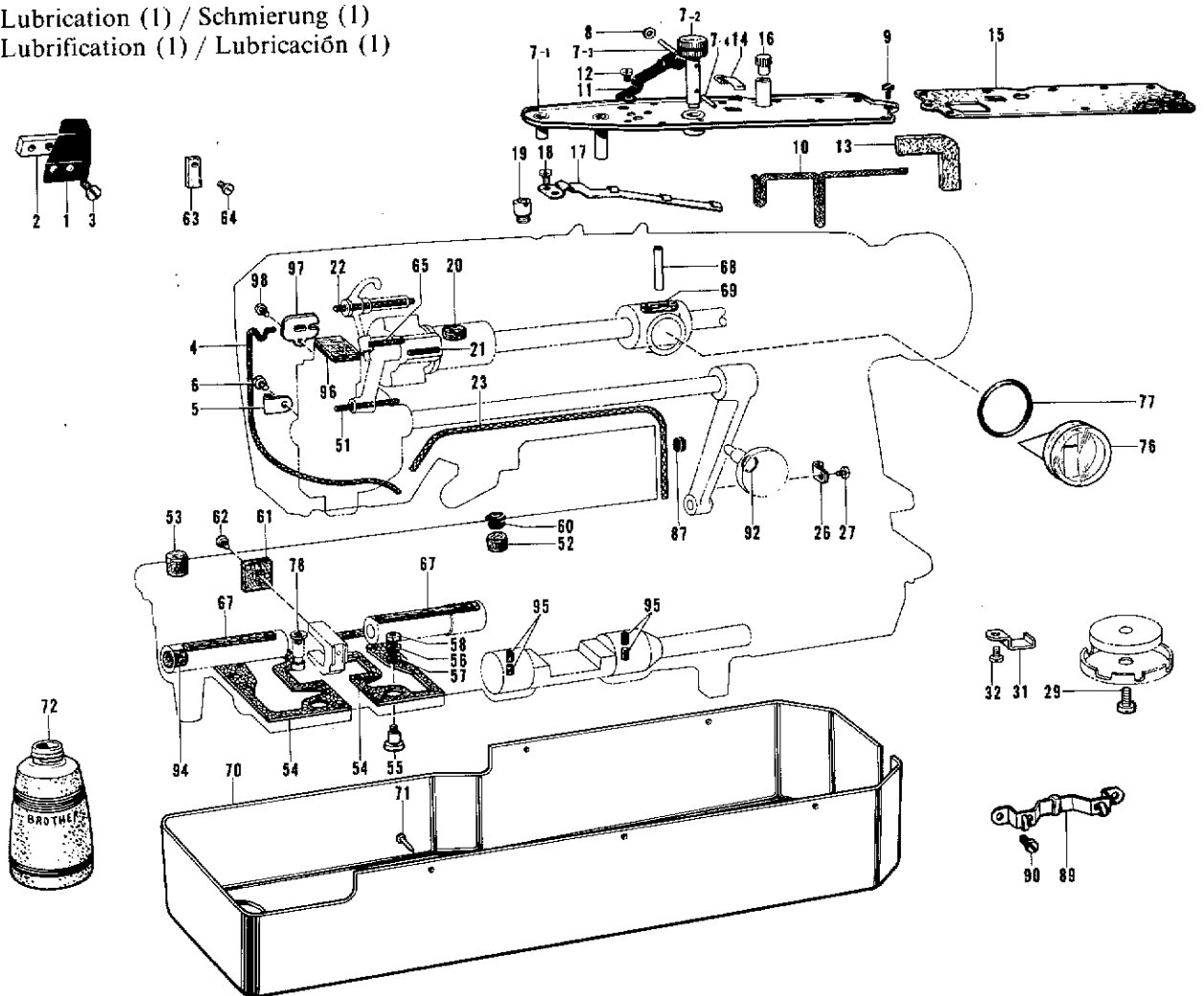

Ref. No.	Name of Parts	Qty	Parts No.	Assembly No.	Ref. No.	Name of Parts	Qty	Parts No.	Assembly No.
1	Oil Stopper Plate	1	112716-0-01		52	Felt	1	112753-0-01	
2	Oil Stopper Plate Presser	1	112717-0-01		53	Felt	1	112754-0-01	
3	Screw 4.76 x 8	1	009710-8-12		54	Packing	2	112755-0-01	
4	Wick 4 x 4 (35 cm)	1	150374-0-00		55	Oil Adjusting Screw	2	112756-0-01	
5	Wick Supporter	2	112739-0-01		56	Spring Washer 2-4.37	2	028680-2-42	
6	Screw 3.57 x 5	2	009670-5-12		57	Washer	2	100645-0-03	
7-1	Oil Receiver Plate	1		M-7 Oil Receiver Plate Assembly 112762-0-01	58	Nut 4.37	2	105234-0-03	
7-2	Oil Adjusting Knob	1			60	Oil Cap	1	112758-0-01	
7-3	Pin	1			61	Felt	1	112759-0-01	
7-4	Pin	1			62	Screw 3.57	1	100242-0-03	
8	Washer	1	503093-0-01		63	Felt	1	148762-0-01	
9	Screw 3.57 x 6	10	009670-6-12		64	Screw 3.57 x 6	1	001670-6-12	
10	Wick 4 x 4 (25 cm)	1	112725-0-01		65	Wick 3 x 3 (3 cm)	1	114693-0-01	
11	Spring Plate	1	112730-0-01		67	Felt (Right)	2	113362-0-01	
12	Screw 3.57 x 3.5	1	009679-3-12		68	Pipe	1	112696-0-00	
13	Felt	1	112724-0-01		69	Felt	1	100248-0-01	
14	Felt Presser	1	114297-0-01		70	Oil Pan	1	151007-1-01	
15	Packing	1	112723-0-01		71	Nail	5	109714-0-00	
16	Cap for Oil Inlet	1	113526-0-01		72	Oiler	1	114486-0-02	
17	Wick Holder	1	143657-0-01		76	Oil Gauge Window	1	116558-0-01	
18	Screw 3.18	2	106640-0-01		77	Packing P16	1	081016-0-70	
19	Oil Guide Tube	1	113524-0-01		78	Felt	2	107155-0-01	
20	Felt	1	112734-0-01		87	Cap	1	143766-0-01	
21	Wick 4 x 4 (12 cm)	1	112735-0-00		89	Wick Support	1	143673-0-01	
22	Wick 6 x 6 (10 cm)	1	112735-0-01		90	Screw 3.18 x 4	2	009660-4-12	
23	Wick 4 x 4 (85 cm)	1	112736-0-00		92	Packing	1	108549-0-01	
26	Wick Supporter	1	112739-0-01		94	Felt	1	115249-0-01	
27	Screw 3.57 x 5	1	009670-5-12		95	Felt	4	148743-0-01	
29	Screw 4.76 x 10	1	009711-0-12		96	Felt	1	149834-0-00	
31	Felt Presser	2	114297-0-01		97	Wick Cover	1	149626-0-01	
32	Screw 3.57 x 5	2	009670-5-12		98	Screw 3.18 x 5	1	001660-5-12	
51	Wick 4 x 4 (5 cm)	1	150825-0-01						

M. Lubrication (2)(Standard)  
 Schmierung (2)(Norm)  
 Lubrification (2)(Standard)  
 Lubricación (2)(Norma)

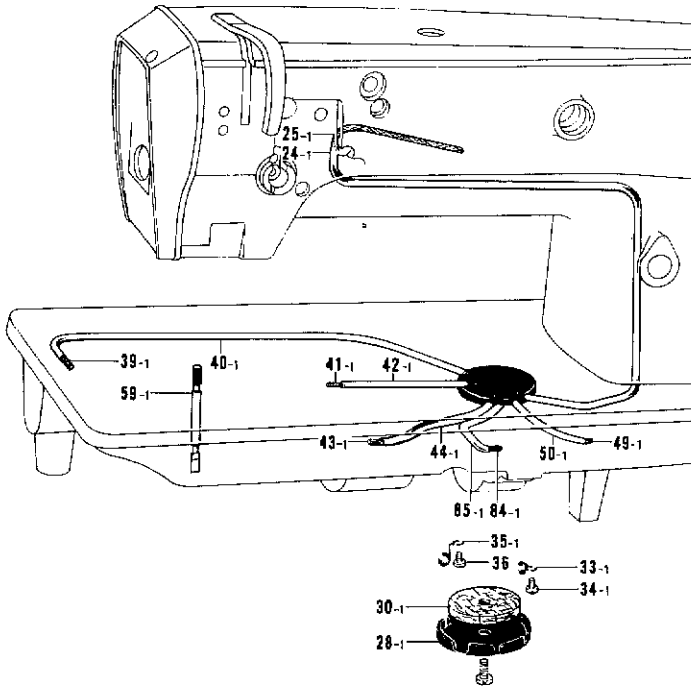

Ref. No.	Name of Parts	Q'ty	Parts No.	Assembly No.
24-1	Oil Tube	1	112737-0-01	
25-1	Wick 4 x 4 (75 cm)	1	112738-0-00	
28-1	Oil Pipe Supporter	1	151083-0-01	
30-1	Oil Felt	1	112741-0-01	
33-1	Tube Holder	4	112743-0-01	
34-1	Screw 3.57 x 5	4	009670-5-12	
35-1	Tube Holder	2	112744-0-01	
36	Screw 3.57 x 5	2	009670-5-12	
39-1	Wick 4 x 4 (33 cm)	1	143660-0-00	
40-1	Vinyl Tube	1	143661-0-00	
41-1	Wick 4 x 4 (40 cm)	1	143662-0-00	
42-1	Oil Tube	1	151084-0-00	
43-1	Wick 4 x 4 (15 cm)	1	143668-0-00	
44-1	Oil Tube	1	143669-0-00	
49-1	Wick 4 x 4 (45 cm)	1	143670-0-00	
50-1	Oil Tube	1	143671-0-00	
59-1	Oil Gauge	2	112757-0-01	
84-1	Wick 4 x 4 (55 cm)	1	143668-0-00	
85-1	Oil Tube	1	143669-0-00	

M. Lubrication (3)[-400A.-700A.-900A]  
 Schmierung (3)[-400A.-700A.-900A]  
 Lubrification (3)[-400A.-700A.-900A]  
 Lubricación (3)[-400A.-700A.-900A]

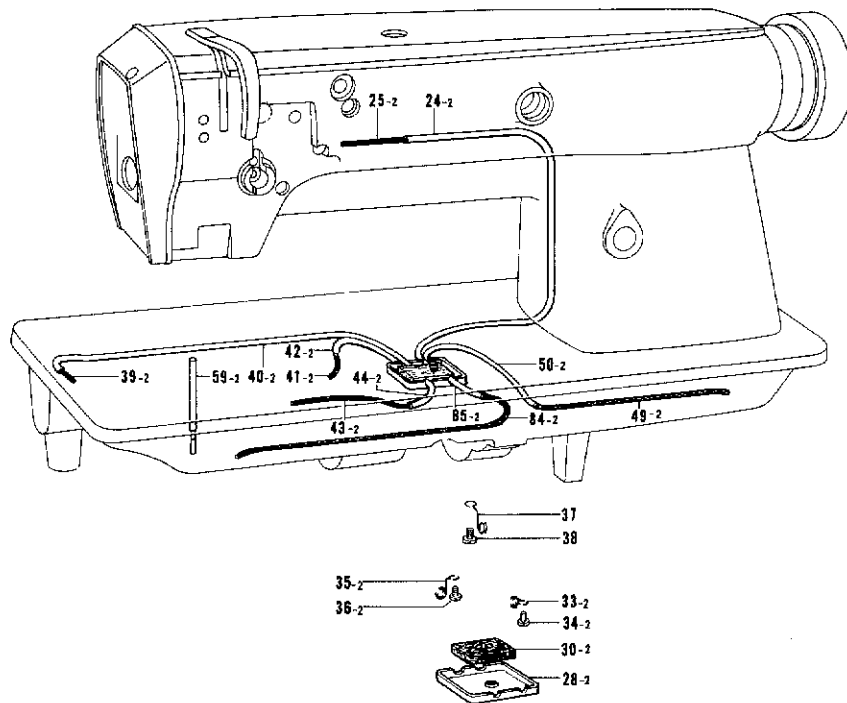

Ref. No.	Name of Parts	Q'ty	Parts No.	Assembly No.	Ref. No.	Name of Parts	Q'ty	Parts No.	Assembly No.
24-2	Oil Tube	1	148730-0-01		40-2	Oil Tube	1	148741-0-01	
25-2	Wick 4 x 4 (80 cm)	1	148731-0-00		41-2	Wick 4 x 4 (16 cm)	1	148740-0-00	
28-2	Oil Tube Supporter	1	148729-0-01		42-2	Oil Tube	1	148733-0-01	
30-2	Felt	1	148732-0-01		43-2	Wick 4 x 4 (30 cm)	1	148736-0-00	
33-2	Tube Holder	3	112743-0-01		44-2	Oil Tube	1	112669-0-01	
34-2	Screw 3.57 x 5	3	009670-5-12		49-2	Wick 4 x 4 (38 cm)	1	148734-0-00	
35-2	Tube Holder	1	112744-0-01		50-2	Oil Tube	1	148733-0-01	
36-2	Screw 3.57 x 5	1	009670-5-12		59-2	Oil Gauge	2	148728-0-01	
37	Wick Holder	1	112745-0-01		84-2	Wick 4 x 4 (53 cm)	1	148738-0-00	
38	Screw 3.57 x 5	1	009670-5-12		85-2	Oil Tube	1	148737-0-01	
39-2	Wick 4 x 4 (35 cm)	1	148742-0-00						

**N. Thread wiper mechanism [-400A--700A--900A]  
 Fadenwischvorrichtung [-400A--700A--900A]  
 Mécanisme de tire-fil [-400A--700A--900A]  
 Mecanismo de limpiador de hilos [-400A--700A--900A]**

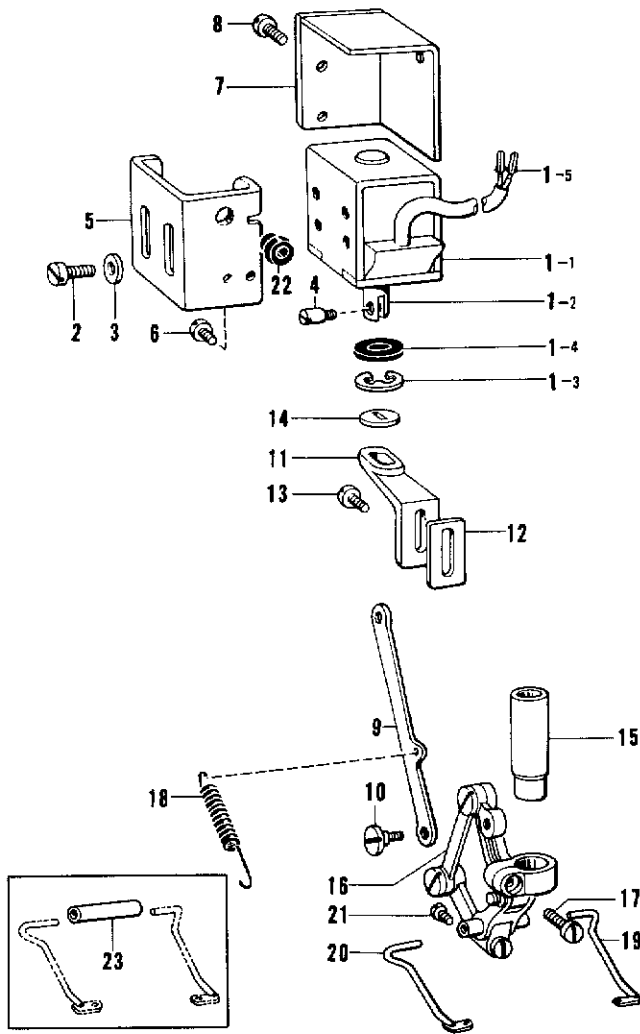

**P. Quick reverse switch mechanism [-400A--700A--900A]  
 Umkehrschalter [-400A--700A--900A]  
 Mécanisme de interrupteur de marche arrière rapide [-400A--700A--900A]  
 Mecanismo de conmutador de inversión rápida [-400A--700A--900A]**

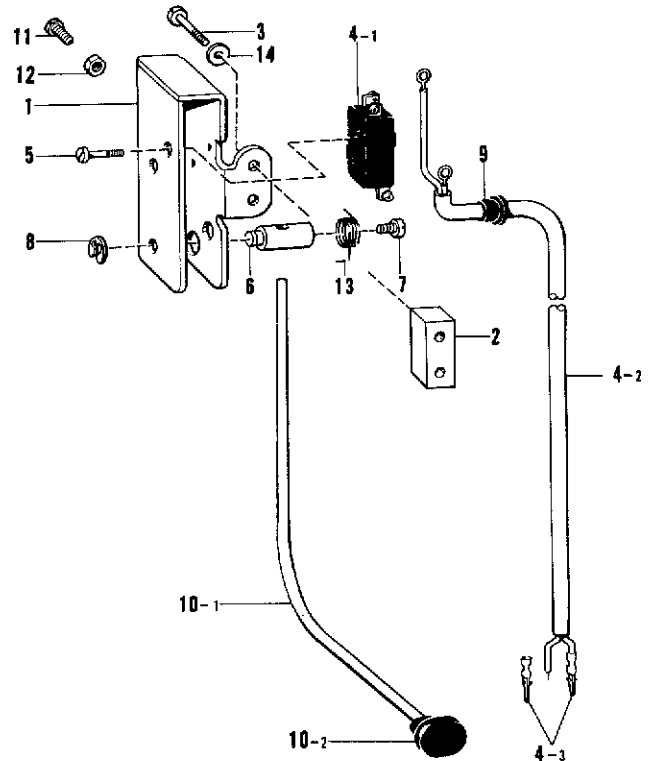

Ref. No.	Name of Parts	Q'ty	Parts No.	Assembly No.
1-1	Solenoid	1		N-1 Thread Wiper Solenoid (for EFKA Motor) 156546-0-01 (for Brother Motor) 159898-0-01 (for 900A) 158815-0-01
1-2	Plunger	1	148511-0-01	
1-3	Stop Ring	1	048090-3-42	(for Brother Motor)
1-4	Rubber Stopper	1	148512-0-00	
1-5	Terminal Pin (for-900A, Brother Motor)	2	143549-0-00	
2	Screw 4 x 10	4	007401-0-12	
3	Washer 4	4	025040-2-32	
4	Plunger Pin	1	148546-0-01	
5	Solenoid Bracket	1	148513-0-02	
6	Screw 4.37	2	107407-0-03	
7	Solenoid Cover	1	148514-0-02	
8	Screw 3.57 x 3.5	3	009679-3-12	
9	Solenoid Link	1	148515-0-01	
10	Stud Screw 3.18	1	148521-0-01	
11	Stopper	1	148516-0-01	
12	Stopper Cork	1	148517-0-00	
13	Screw 4.37	2	107407-0-03	
14	Rubber Stopper	1	148518-0-00	
15	Presser Bar Bushing (Lower)	1	148508-0-01	
16	Thread Wiper Link	1	148770-1-01	
17	Screw 4.76 x 14	1	009711-4-12	
18	Spring (for-3)	1	148526-0-01	
	Spring (for-5)	1	148527-0-01	
19	Thread Wiper (Right)	1	148529-0-01	
20	Thread Wiper (Left)	1	148530-0-01	
21	Screw	2	149177-0-01	
22	Bushing	1	146080-0-00	
23	Thread Wiper Holder (1/8~3/8)	1	148528-0-01	
	Thread Wiper Holder (L)(5/8)	1	149986-0-01	

Ref. No.	Name of Parts	Q'ty	Parts No.	Assembly No.
1	Micro Switch Base	1	159806-0-01	
2	Spacer	1	149873-0-01	
3	Screw 3.57	2	120311-0-02	
4-1	Micro Switch	1	140643-0-00	P-4 Reverse Switch Assembly (for EFKA Motor) 156548-0-01 (for Brother Motor) 159896-0-00 (for 900A) 158817-0-00
4-2	Reverse Cord	1		
4-3	Terminal Pin (for-900A, Brother Motor)	2	143549-0-00	
5	Screw 2.38	2	146124-0-01	
6	Actuator Shaft	1	156998-0-01	
7	Screw 4.37 x 10	1	009681-0-12	
8	Stop Ring E4	1	048040-3-42	
9	Bushing	1	146080-0-00	
10-1	Actuator Bar	1		P-10 Actuator Assembly 159807-0-01
10-2	Push Button	1	156479-0-00	
11	Screw 4.37 x 14	1	009681-4-12	
12	Nut 4.37	1	102571-0-03	
13	Spring	1	157999-0-01	
14	Washer	2	105161-0-03	

Q. Thread trimmer mechanism [-400A.-700A.-900A] / Fadenabschneidevorrichtung [-400A.-700A.-900A]  
 Mécanisme de coupe-fill [-400A.-700A.-900A] / Mecanismo de recortadora de orillos [-400A.-700A.-900A]

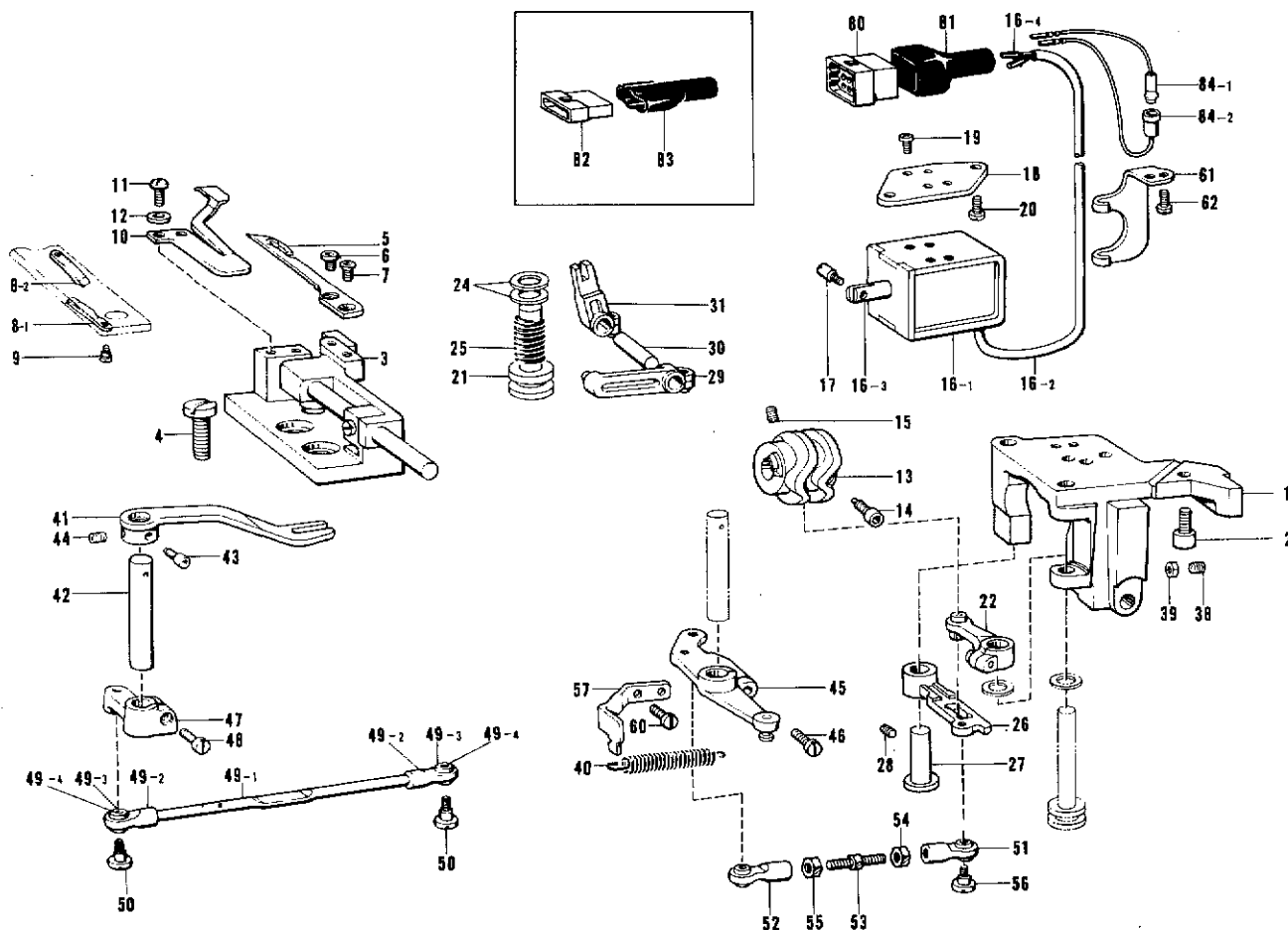

Ref. No.	Name of Parts	Qty	Parts No.	Assembly No.	Ref No.	Name of Parts	Qty	Parts No.	Assembly No.
1	Movable Knife Base Bracket	1	148482-1-01		31	Knife Driving	1	181713-0-01	
2	Bolt 6 x 16	3	018061-6-22		38	Screw 7.14	1	011802-0-12	
3	Movable Knife Base Assembly	2	159362-0-01		39	Nut 7.14	1	100078-0-03	
4	Screw 4.76 x 8	4	009710-8-12		40	Spring	1	143609-0-01	
5	Movable Knife	2	159365-0-01		41	Knife Rock Arm	2	159366-0-01	
6	Screw 4.37	2	148536-0-01		42	Knife Rock Arm Shaft	2	148573-0-01	
7	Screw 4.37	2	148537-0-01		43	Screw 6.35	2	148574-0-01	
8-1	Fixed Knife (Left)	1	148538-0-01		44	Screw 6.35 x 6	2	014770-6-22	
8-2	Fixed Knife (Right)	1	149169-0-01		45	Knife Rock Lever Right Assembly	1	148575-0-01	
9	Stud Screw 2.38	2	148539-0-01		46	Screw 4.76 x 14	1	009711-4-12	
10	Thread Presser Spring	2	150821-1-00		47	Knife Rock Lever (Left)	1	158751-0-01	
11	Screw 2.38 x 4	4	001630-4-02		48	Screw 4.76 x 14	1	009711-4-12	
12	Washer 2.38	4	025630-1-32		49-1	Knife Connecting Bar	1		Q-49 Connecting Rod Assembly 3/32-5/32 148381-0-01 3/16-1/8 148383-0-01 5/16-3/8 148697-0-01 5/8 149958-0-01
13	Knife Driving Cam	1	158772-0-01		49-2	Joint	2	148584-0-01	
14	Screw 6.35	1	148574-0-01		49-3	Bushing	2		
15	Screw 6.35 x 6	1	014770-6-22		49-4	Spring Pin AW2	2		
16-1	Thread Trimmer	1		Q-16 Thread Trimmer Solenoid (for EFK-A Motor) 156550-0-01 (for Brother Motor) 159900-0-01 (for -900) 158812-0-01	50	Screw	2	141494-0-01	
16-2	Solenoid Cord	1			51	Joint Assembly (Right)	1	148587-0-01	
16-3	Plunger	1	148545-0-01		52	Joint Assembly (Left)	1	148589-0-01	
16-4	Terminal Pin (for Brother Motor)	2	143549-0-00		53	Connecting Screw	1	148591-0-01	
17	Pin	1	148546-0-01		54	Nut 5.95	1	148592-0-01	
18	Solenoid Bracket	1	148561-1-01		55	Nut 5.95	1	100022-0-05	
19	Screw 4 x 8	4	002400-8-03		56	Screw	2	141494-0-01	
20	Screw 4.76 x 10	2	009711-0-12		57	Spring Hook (Right)	1	148579-0-01	
21	Knife Main Lever Shaft	1	148547-0-01		60	Screw 4.76 x 10	2	009711-0-12	
22	Knife Main Lever	1	148548-0-01		61	Cord Supporter	1	148655-0-01	
24	Rubber	2	148559-0-00		62	Screw 4.76 x 8	2	009710-8-12	
25	Spring	1	148555-0-01		80	Nylon Connector 12P (for Brother Motor)	1	153969-0-00	
26	Knife Sub Lever	1	158814-0-01		81	Connector Cap 5 (for Brother Motor)	1	153971-0-01	
27	Knife Sub Lever Shaft	1	148554-0-01		82	Nylon Connector (for-900A)	1	143520-0-00	
28	Screw 5.95	1	100289-0-03		83	Plug Cover #2 (for-900A)	1	216248-0-01	
29	Knife Driving Pin Lever	1	181712-0-01		84-1	Cord (R)	1	S00897-0-00	Q-R4 Cord Assembly (for Brother Motor) S00896-0-00
30	Knife Driving Lever Shaft 6.35 x 27	1	148557-0-01		84-2	Cord (P)	1	S00899-0-00	

R. Tension release mechanism [-400A.-700A.-900A] / Spannung sverminderung svorrichtung [-400A.-700A.-900A]  
 Mécanisme de relâche-tension [-400A.-700A.-900A] / Mecanismo de liberador de tensión [-400A.-700A.-900A]

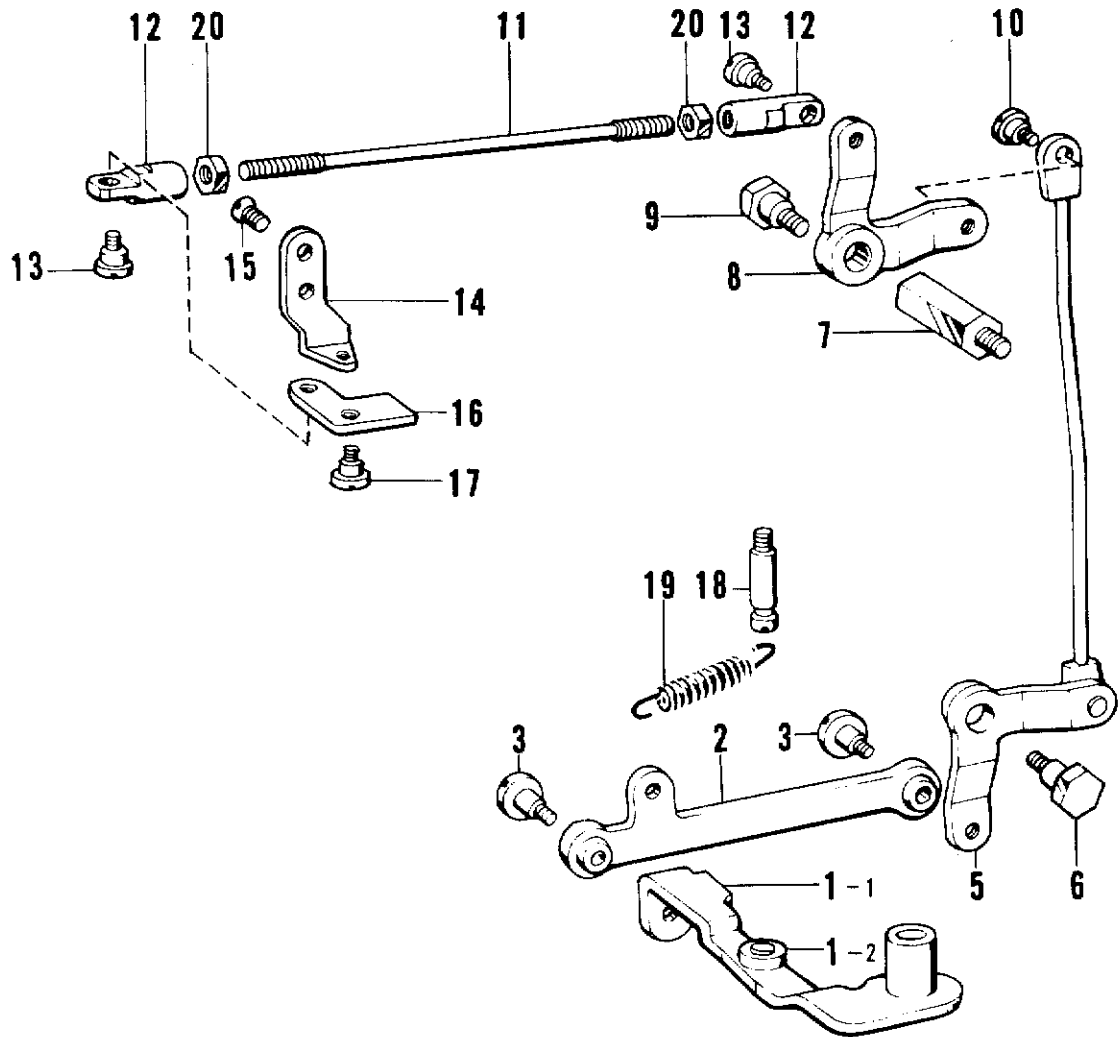

Ref. No.	Name of Parts	Q'ty	Parts No.	Assembly No.	Ref. No.	Name of Parts	Q'ty	Parts No.	Assembly No.
1-1	Tension Release Rock Lever	1		R-1 Tension Release Rock Lever Assembly 148619-0-01	11	Tension Release Rod Upper	1	148631-0-01	
1-2	Tension Release Roller Stud	1			12	Joint	2	148632-0-01	
2	Tension Release Connecting Rod Lower	1	148623-0-01		13	Screw	2	148768-0-01	
3	Stud Screw 4.37	2	123882-0-01		14	Tension Release Plate	1	148634-0-01	
5	Tension Release Crank Lower	1	148625-0-01		15	Screw 4.37	2	117160-0-01	
6	Stud Screw 6.35	1	148628-0-01		16	Tension Release Crank	1	148635-0-01	
7	Stud	1	148629-0-01		17	Stud Screw 3.57	1	148633-0-01	
8	Tension Release Crank Upper	1	148630-0-01		18	Spring Hook	1	115177-0-01	
9	Stud Screw 6.35	1	148628-0-01		19	Spring	1	148654-0-01	
10	Stud Screw 4.76	1	110171-0-01		20	Nut 3.57	2	021670-1-02	

S. Synchronizer (1)[-400A.-700A]  
 Synchronisator (1)[-400A.-700A]  
 Synchronisateur (1)[-400A.-700A]  
 Sincronizador (1)[-400A.-700A]

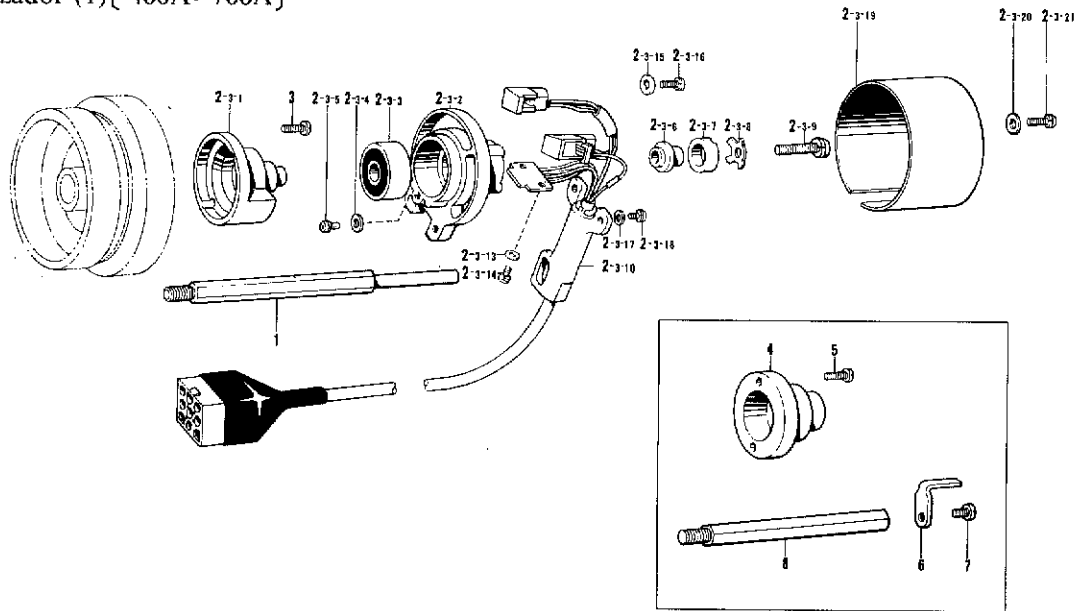

Ref. No.	Name of Parts	Q'ty	Parts No.	Assembly No.	Ref. No.	Name of Parts	Q'ty	Parts No.	Assembly No.
1	Synchronizer Holder Stud	1	148615-0-01	S-2-3 Synchronizer Assembly #10-2 (for Brother Motor) 224357-0-01	2-3-15	Washer 4	2	025040-3-35	S-2-3 Synchronizer Assembly #10-2 (for Brother Motor) 224357-0-01
2-3-1	Magnet Stud	1			2-3-16	Screw 4 x 12D	2	217093-0-01	
2-3-2	Synchronizer Holder #3	1			2-3-17	Washer 4	2	025040-1-35	
2-3-3	Ball Bearing 6201VV	1			2-3-18	Screw 4 x 12D	2	217093-0-01	
2-3-4	Washer 3	1	025030-3-35		2-3-19	Synchronizer Cover #4	1		
2-3-5	Screw 3 x 6D	1	215083-0-01		2-3-20	Washer 4	2	025040-3-35	
2-3-6	Magnet Setting Bracket	1	219557-0-00		2-3-21	Screw 4 x 12D	2	217093-0-01	
2-3-7	Magnet 12 x 18.7 x 6	1	219558-0-00		3	Screw 4.76 x 14	2	009711-4-12	
2-3-8	Magnet Holder Plate	1	219559-0-00		4	Slip Ring Support (for EFKA Motor)	1	148825-0-01	
2-3-9	Screw 6 x 25D	1	221421-0-01		5	Screw 4.76 x 14 (for EFKA Motor)	2	009711-4-12	
2-3-10	Hole I.C with Cord #7	1			6	Synchronizer Holder (for EFKA Motor)	1	158775-0-01	
2-3-13	Washer 3	2	025030-1-35		7	Screw 4.37 x 7 (for EFKA Motor)	1	009680-7-12	
2-3-14	Screw 3 x 6D	2	215083-0-01		8	Synchronizer Holder Stud (for EFKA Motor)	1	158776-0-01	

S. Synchronizer (2)[-900A]  
 Synchronisator (2)[-900A]  
 Synchronisateur (2)[-900A]  
 Sincronizador (2)[-900A]

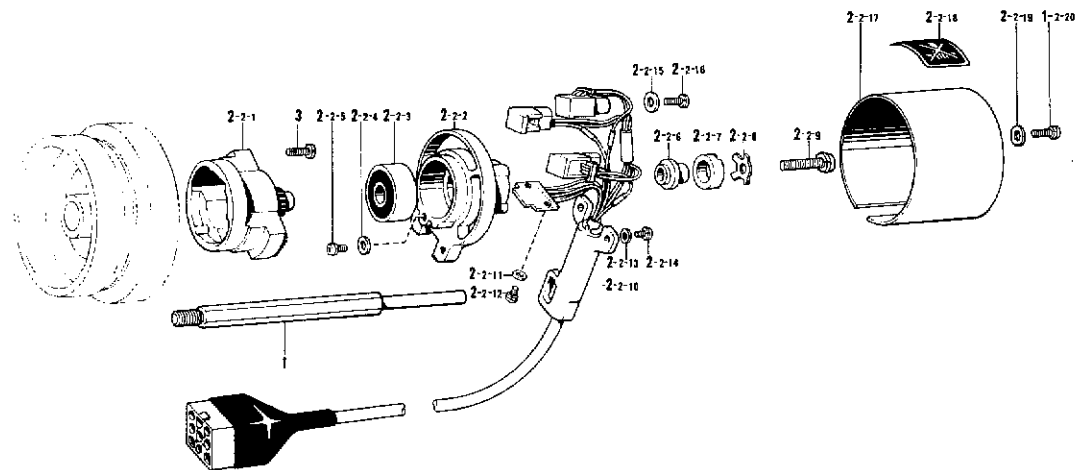

Ref. No.	Name of Parts	Q'ty	Parts No.	Assembly No.	Ref. No.	Name of Parts	Q'ty	Parts No.	Assembly No.
1	Synchronizer Holder Stud	1	148615-0-01	S-2-2 Synchronizer Assembly #7 222370-0-01	2-2-11	Washer 3	2	025030-1-35	S-2-2 Synchronizer Assembly #7 222370-0-01
2-2-1	Magnet Stud	1			2-2-12	Screw 3 x 6D	2	215083-0-01	
2-2-2	Synchronizer Holder #3	1			2-2-13	Washer 4	2	025040-1-35	
2-2-3	Ball Bearing 6201VV	1			2-2-14	Screw 4 x 10D	2	215080-0-01	
2-2-4	Washer 3	1	025030-3-35		2-2-15	Washer 4	3	025040-3-35	
2-2-5	Screw 3 x 6D	1	215083-0-01		2-2-16	Screw 4 x 12D	3	217093-0-01	
2-2-6	Magnet Setting Bracket	1	219557-0-00		2-2-17	Synchronizer Cover #3	1		
2-2-7	Magnet 12 x 18.7 x 6	1	219558-0-00		2-2-18	Label #2	1		
2-2-8	Magnet Holder Plate	1	219559-0-00		2-2-19	Washer 4	2	025040-3-35	
2-2-9	Screw 6 x 25D	1	221421-0-01		2-2-20	Screw 4 x 10D	2	215080-0-01	
2-2-10	Hole I.C with Cord #3	1			3	Screw 4.76 x 14	2	009711-4-12	

T. Gauge parts mechanism / Lehren  
Pièces d'écartement / Piezas calibradoras

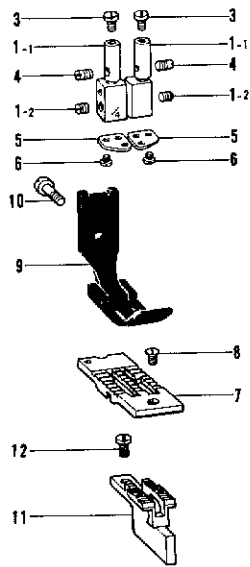

Ref. No.	Name of Parts	Qty	Parts No.	Assembly No.
1-1	Needle Clamp	2		T-1 Needle Clamp with Screw *
1-2	Screw 3.18 x 4	2	013660-4-12	
3	Screw 3.18	2	149831-0-01	
4	Screw 3.18	2	149833-0-01	
5	Thread Guide Plate	2	149832-0-01	
6	Screw 1.98	2	107404-0-01	
7	Needle Plate (Assembly)	1	*	
8	Screw 4.37	1	100032-0-04	
9	Presser Foot	1	*	
10	Screw 3.57	1	113050-0-01	
11	Feed Dog	1	*	
12	Screw 3.18	2	116283-0-01	

- ⊙If there is a "\*" mark in the part code column or assembly code column, refer to the gauge parts list.
- ⊙Falls in den kolonnen für Teilcode und Satzcode das Zeichen "\*" steht, wird auf die Lehren liste auf verwiesen.
- ⊙Si le signe apparaît dans la colonne du code des pièces ou dans celle du code d'assemblage, se reporter à la liste des pièces de la jauge.
- ⊙Si aparece una marca "\*" en la columna de código de piezas o en la columna de código de armado, consultar la lista de piezas calibradoras.

Gauge parts list (Standard) / Liste des pièces d'écartement (Standard)  
Lehren liste (Norm) / Lista de piezas calibradoras (Norma)

Gauge Size Lehre Taille de jauge Tamaño de galga	Sub Class Untergruppe Sous-classe Subclase	Needle Clamp Nadelklammer Pince-aiguille Ménsula de aguja	Needle Plate Stichplatte Plateau à aiguille Placa de aguja	Feed Dog Transporteur Griffe d'entraînement Alimentador	Presser Foot Stoffdrückfuß Presseur Prensatelas	Presser Foot with Guide Stoffrückfuß mit Führung Pied Presseur avec guide Pie del Prensatelas con guía
1/8inch(3.2mm)	-3	150885-0-01	117369-0-01	114951-0-01	114948-0-01	149311-0-01
	-5					
5/32inch(4.0mm)	-3	150843-0-01	150850-0-01	116509-0-01	116502-0-01	
	-5					
3/16inch(4.8mm)	-3	150844-0-01	117133-0-01	112659-0-01	112638-0-01	117281-0-01
	-5					
1/4inch(6.4mm)	-3	150830-0-01	117367-0-01	112660-0-01	112642-0-01	149312-0-01
	-5					
5/16inch(7.9mm)	-3	150845-0-01	144882-0-01	112661-0-01	112645-0-01	
	-5					
3/8inch(9.5mm)	-3	150846-0-01	144881-1-01	116510-1-01	116498-0-01	
	-5					
5/8inch(15.9mm)	-3	156530-0-01	116507-0-01	116512-0-01	116500-0-01	
	-5					

Gauge parts list (Thread trimmer) / Liste des pièces d'écartement (Coupe-fil)  
Lehren liste (Fadenabschneider) / Lista de piezas calibradoras (Cortahilos)

Gauge Size Lehre Taille de jauge Tamaño de galga	Sub class Untergruppe Sous-classe Subclase	Needle Clamp Nadelklammer Pince-aiguille Ménsula de aguja	Needle Plate Stichplatte Plateau à aiguille Placa de aguja	Feed Dog Transporteur Griffe d'entraînement Alimentador	Presser Foot Stoffdrückfuß Presseur Prensatelas	Connecting rod assembly Verbindungsstange kompl. Bielle Conjunto de la varilla de conexión	Thread wiper guide Fadenwischerführung Guide de tire-fils Guía del retirador de hilos
1/8inch(3.2mm)	-3	150885-0-01	155722-0-01	148698-0-01	148685-0-01	148581-0-01	
	-5			148699-0-01	148681-0-01		
5/32inch(4.0mm)	-3	150843-0-01	155724-0-01	148700-0-01	148689-0-01		
	-5			148701-0-01	148683-0-01		
3/16inch(4.8mm)	-3	150844-0-01	155851-0-01	148702-0-01	148687-0-01		
	-5			148703-0-01	148691-0-01		
7/32inch(5.6mm)	-3	183180-0-01	156816-0-01	156818-0-01	156819-0-01	148585-0-01	148528-0-01
	-5			148704-0-01	148693-0-01		
1/4inch(6.4mm)	-3	150830-0-01	155853-0-01	148705-0-01	148695-0-01		
	-5			*158756-0-01			
5/16inch(7.9mm)	-3	150845-0-01	155855-0-01	149692-0-01	149689-0-01	149697-0-01	
	-5			149691-0-01	149687-0-01		
3/8inch(9.5mm)	-3	150846-0-01	155857-0-01	149939-0-01	149942-0-01		
	-5			149938-0-01	149940-0-01		
5/8inch(15.9mm)	-3	156530-0-01	149954-0-01	149949-0-01	149952-0-01	149958-0-01	149986-0-01
	-5			149948-0-01	149950-0-01		

\*Special Needle Hole

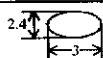

U. Control box mechanism (1)[-700A BROTHER Motor] / Schaltkasten (1)[-700A BROTHER Motor]  
 Mécanisme du boîtier de contrôle (1)[-700A BROTHER Moteur] / Mecanismo del caja de controles (1)[-700A BROTHER Motor]

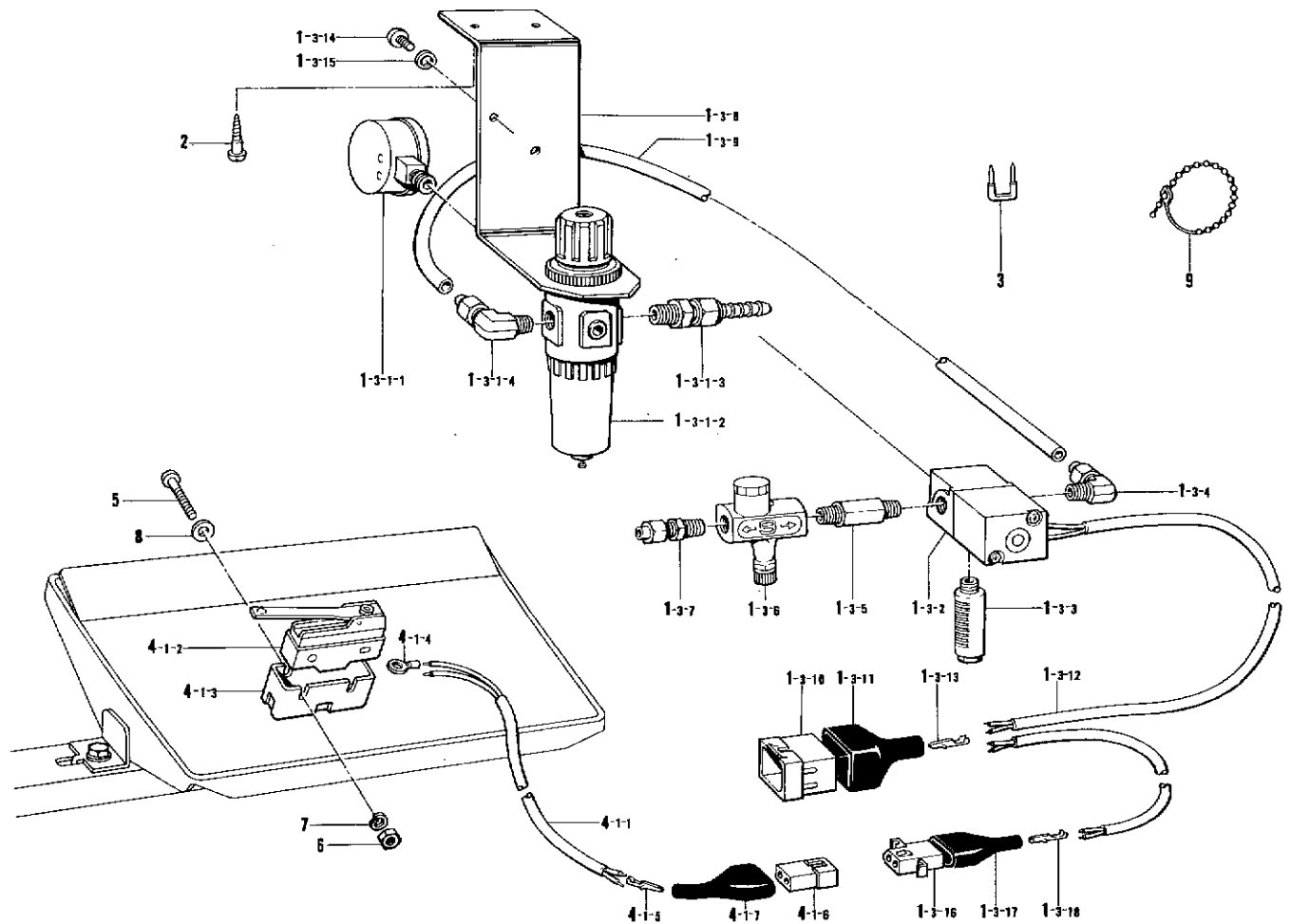

Ref. No.	Name of Parts	Q'ty	Parts No.	Assembly No.	Ref. No.	Name of Parts	Q'ty	Parts No.	Assembly No.
1-3- 1-1	Presser Gauge	1		U-1-3-1 Air Unit Assembly 151153-1-01	1-3-16	Nylon Connector	1	143499-0-00	U-1-3 Air Unit Valve Assembly
1-3- 1-2	Valve	1	143960-1-01		1-3-17	Connector Cap	1	143489-0-01	
1-3- 1-3	Air Tube Connector	1	140678-0-00	U-1-3 Air Unit Valve Assembly 159813-0-01	1-3-18	Terminal Pin	2	143548-0-00	U-4-1 Presser Foot Lifter Cord Assembly 146160-0-01
1-3- 1-4	1/4 Elbow	1	140538-0-00		2	Screw 4.5 x 20	2	101118-0-01	
1-3- 2	Air Valve	1	159814-0-00		3	Staple	8	200190-0-01	
1-3- 3	Silencer	1	140682-0-01		4-1- 1	Presser Foot Lifter Cord	1		
1-3- 4	1/8 Elbow Assembly	1	151147-0-01		4-1- 2	Micro Switch	1	140948-0-01	
1-3- 5	Speed Control Connector	1	142037-0-00		4-1- 3	Cover	1	140950-0-00	
1-3- 6	Speed Controller	1	142038-0-01		4-1- 4	Terminal	2	140693-0-00	
1-3- 7	1/8 Connector	1	140543-0-00		4-1- 5	Terminal Pin	2	143549-0-00	
1-3- 8	Air Unit Holder Plate	1			4-1- 6	Nylon Connector	1	143488-0-01	
1-3- 9	Air Tube	1	140540-0-00		4-1- 7	Connector Cap	1	143489-0-01	
1-3-10	6P Nylon Connector	1	146118-0-00		5	Screw 3 x 30	2	002303-0-06	
1-3-11	Connector Cap	1	145596-0-01		6	Nut 3	2	021300-1-03	
1-3-12	Tube	1			7	Washer 2-3	2	028030-2-43	
1-3-13	Terminal Pin	2	143549-0-00		8	Washer 3	2	025030-2-33	
1-3-14	Screw 5 x 10	2	002501-0-03		9	Bead Band	1	144189-0-01	
1-3-15	Washer 2-5	2	028050-2-43						

U. Control box mechanism (2)[-900A] / Schaltkasten (2)[-900A]  
 Mécanisme du boîtier de contrôle (2)[-900A] / Mecanismo del caja de controles (2)[-900A]

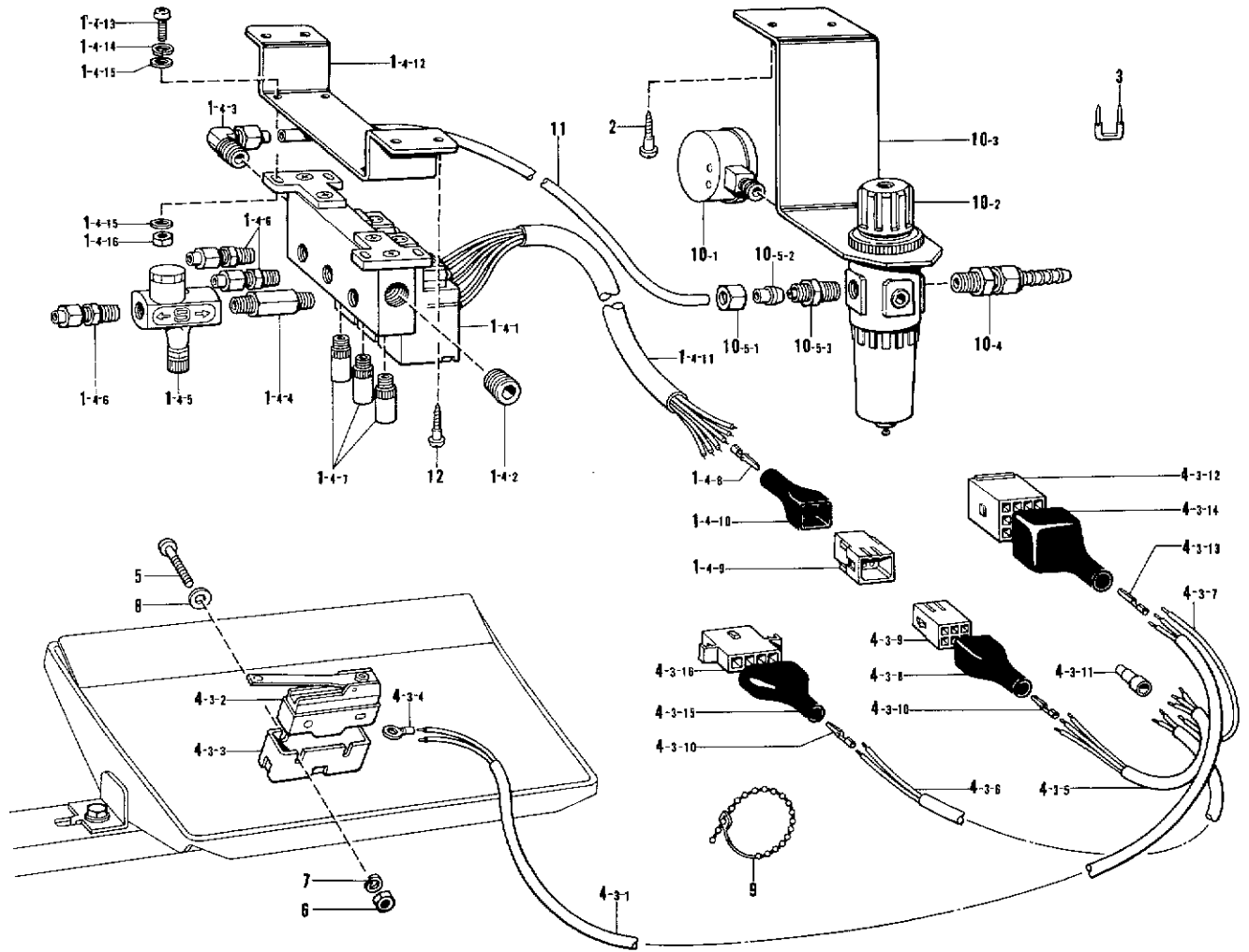

Ref. No.	Name of Parts	Q'ty	Parts No.	Assembly No.	Ref. No.	Name of Parts	Q'ty	Parts No.	Assembly No.
1-4-1	Manifold Valve	1	159889-0-01	U-1 Solenoid Valve Assembly (for -900A) 159890-0-01	4-3-7	Cord	1	159894-0-00	U-4-3 Presser Foot Lifter Cord Assembly 159895-0-01
1-4-2	Cap	1	140542-0-01		4-3-8	Connector Cover	1	216384-0-01	
1-4-3	1/4 Elbow	1	140538-0-00		4-3-9	Nylon Connector	1	216382-0-01	
1-4-4	Speed Control Connector	1	142037-0-00		4-3-10	Terminal Pin	10	143548-0-00	
1-4-5	Speed Controller	1	142038-0-01		4-3-11	Crimp Connector	1	S00391-0-00	
1-4-6	1/8 Connector	3	140543-0-00		4-3-12	Nylon Connector 12P	1	153433-0-00	
1-4-7	Silencer	3	159874-0-00		4-3-13	Terminal Pin	8	143549-0-00	
1-4-8	Terminal Pin	6	143549-0-00		4-3-14	Connector Cover #15	1	221786-0-01	
1-4-9	Nylon Connector	1	216323-0-01		4-3-15	Connector Cap	1	143519-0-01	
1-4-10	Connector Cover	1	216324-0-01		4-3-16	Nylon Connector	1	143501-0-00	
1-4-11	Tube	1			5	Screw 3 x 30	2	002303-0-06	
1-4-12	Valve Holder Plate	1	S00325-0-01		6	Nut 3	2	021300-1-03	
1-4-13	Screw 4 x 14	4	002401-4-02		7	Washer 2-3	2	028030-2-43	
1-4-14	Washer 2-4	4	028040-2-43		8	Washer 3	2	025030-2-33	
1-4-15	Washer 4	8	025040-2-33		9	Bead Band	1	144189-0-01	
1-4-16	Nut 4	4	021400-1-06		10-1	Presser Gauge	1		
2	Screw 4.5 x 20	2	101118-0-01	10-2	Valve	1	143960-1-01		
3	Staple	8	200190-0-01	10-3	Air Unit Holder Plate	1			
4-3-1	Presser Foot Lifter Cord	1		10-4	Air Tube Connector	1	140678-0-00		
4-3-2	Micro Switch	1	140948-0-01	10-5-1	Nut 12	1			
4-3-3	Cover	1	140950-0-00	10-5-2	Sleeve SN5/16	1	147191-0-00		
4-3-4	Terminal	2	140693-0-00	10-5-3	1/4 Connector	1			
4-3-5	Cable Assembly	1	159892-0-00	11	Air Tube	1	154309-0-00		
4-3-6	Cable Assembly	1	159893-0-00	12	Screw 4.5 x 20	4	101118-0-01		
								U-10 Air Unit Assembly S00336-0-01	
								U-10-5 Connector Assembly 147189-0-01	

V. Pedal mechanism (Option parts) / Pedal (Option parts)  
 Mécanisme de la pédale (Pièces en option) / Mecanismo de la pedal (Piezas opción)

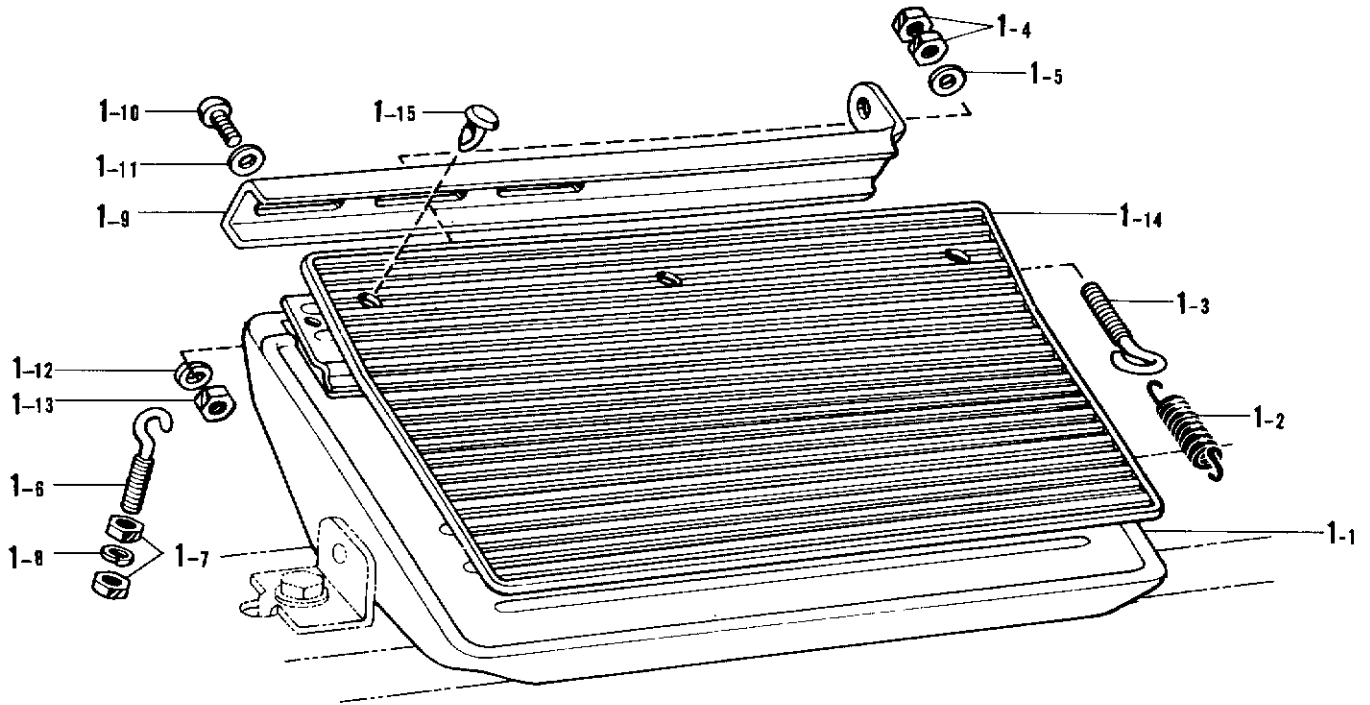

Ref. No.	Name of Parts	Q'ty	Parts No.	Assembly No.	Ref. No.	Name of Parts	Q'ty	Parts No.	Assembly No.
1-1	Treadle	1		V-1 Treadle Assembly 146175-0-01	1-9	Treadle Connector Arm	1		V-1 Treadle Assembly 146175-0-01
1-2	Spring	1	146178-0-01		1-10	Screw 6 x 16	2	001061-6-06	
1-3	Spring Hook	1	140953-0-01		1-11	Washer 6	2	025060-2-36	
1-4	Nut 5	2	021500-1-04		1-12	Washer 2-6	2	028060-2-42	
1-5	Washer 5	1	025050-2-33		1-13	Nut 6	2	021060-2-06	
1-6	Adjusting Hook	1	140947-0-02		1-14	Rubber Cover	1	109268-0-01	
1-7	Nut 4 x 5	2	212251-0-01		1-15	Clip 6	3	146358-0-01	
1-8	Washer 2-4	1	028040-2-43						

Parts No.	Ref. No.	Remark	Parts No.	Ref. No.	Remark	Parts No.	Ref. No.	Remark	Parts No.	Ref. No.	Remark
112596-0-01	D- 5		112737-0-01	M-24- 1		118317-0-01	B -19- 1- 9		143549-0-00	P - 4-3	
112597-0-01	D- 6		112738-0-00	M-25- 1		118320-0-01	B -19- 1-16			Q-16-4	
112598-0-01	D- 8		112739-0-01	M- 5			B -19- 5- 1-18			U- 1-3-13	
112606-0-01	D-10			M-26		118713-0-01	F-41			U- 1-4- 8	
112607-0-01	D-11		112741-0-01	M-30- 1			G-15- 1			U- 4-1- 5	
112609-0-01	D- 1-8-10		112743-0-01	M-33- 1		118735-0-01	E-39			U- 4-3-13	
112610-0-01	D-12			M-33- 2		118746-0-01	G-20		143591-0-01	J -13	
112614-0-01	F - 1		112744-0-01	M-35- 1		118747-0-01	G-22- 1		143594-0-01	G - 1-2	
112615-0-01	F - 2			M-35- 2		118752-0-03	G-25		143597-0-01	G - 2	
112616-0-01	F - 4		112745-0-01	M-37		118837-0-01	Z - 3- 3		143608-0-01	G-27	
112618-0-01	F - 7		112751-0-03	D-15		118853-0-01	G-19		143609-0-01	G-29	
112619-0-01	F - 8		112753-0-01	M-52			G-23			Q-40	
112623-0-01	F -12		112754-0-01	M-53		118865-0-01	L -12		143610-0-01	G-30	
112624-0-01	F -13		112755-0-01	M-54		118954-0-00	G-32- 1- 2		143611-0-01	G-32-1	
112625-0-01	F -14-1		112756-0-01	M-55			G-32- 2- 2		143612-0-00	G-32-1- 1	
112626-0-01	F -15		112757-0-01	M-59- 1		120264-0-01	D- 1-14		143613-0-01	G-32-1- 3	
112628-0-01	F -17		112758-0-01	M-60		120311-0-02	P - 3			G-32-2- 3	
112629-0-01	F -18-1		112759-0-01	M-61		122991-0-01	Z - 1		143616-0-01	G-36	
112630-0-01	F -19		112760-0-01	C -25		123882-0-01	R - 3		143657-0-01	M-17	
112631-0-01	F -20		112762-0-01	M- 7		126863-0-00	Z -16-13		143660-0-00	M-39-1	
112636-0-01	F -25-3		112763-0-01	F -26		140527-0-01	B - 1		143661-0-00	M-40-1	
112638-0-01	T - 9		112764-0-01	D-16		140538-0-00	U - 1- 3- 1- 4		143662-0-00	M-41-1	
112642-0-01	T - 9		112781-0-01	K-27- 1			U - 1- 4- 3		143668-0-00	M-43-1	
112645-0-01	T - 9			Z - 9		140540-0-00	U - 1- 3- 9			M-84-1	
112656-0-01	J -15		113024-0-00	C -15		140542-0-01	U - 1- 4- 2		143669-0-00	M-44-1	
112658-0-01	B -14		113050-0-01	T -10		140543-0-00	U - 1- 3- 7			M-85-1	
	B -21		113074-0-01	J -20			U - 1- 4- 6		143670-0-00	M-49-1	
112659-0-01	T -11		113362-0-01	M-67		140620-0-01	F -36		143671-0-00	M-50-1	
112660-0-01	T -11		113380-0-01	F -29		140643-0-00	P - 4- 1		143673-0-01	M-89	
112661-0-01	T -11		113386-0-00	D-17		140678-0-00	U - 1- 3- 1- 3		143766-0-01	M-87	
112666-0-00	L - 4-1		113524-0-01	M-19			U -10- 4		143910-0-01	Z -38	
112667-0-01	L - 4-2		113526-0-01	M-16		140682-0-01	U - 1- 3- 3		143960-1-01	U - 1-3- 1- 2	
112668-0-01	L - 6		114297-0-01	M-14		140693-0-00	U - 4- 1- 4			U -10-2	
112684-0-01	L -14-2			M-31			U - 4- 3- 4		144189-0-01	U - 9	
	L -17		114447-0-02	D- 1- 8-16		140947-0-02	V - 1- 6		144222-0-01	Z -17	
112685-0-01	K - 1-1		114483-0-02	Z -12		140948-0-01	U - 4- 1- 2		144458-0-01	D-21	
112686-0-01	K - 2		114486-0-02	M-72			U - 4- 3- 2		144504-0-01	B -19-5- 4	
112687-0-01	K - 4		114680-0-01	C -23		140950-0-00	U - 4- 1- 3		144614-0-01	C -16	
112690-0-01	K - 7		114693-0-01	M-65			U - 4- 3- 3		144678-0-01	B -19-1	
112692-0-01	K -10		114909-0-00	F -22		140953-0-01	V - 1- 3		144680-0-01	B -19-1- 2	
112694-0-01	K -13		114941-0-01	B -18		141439-0-01	F -40			B -19-5- 1- 2	
112695-0-01	K -14			Z -10		141494-0-01	F -44		144681-0-01	B -19-1- 3	
112696-0-00	K -16		114948-0-01	T - 9			Q-50		144682-0-01	B -19-1- 5	
	M-68		114951-0-01	T -11			Q-56			B -19-5- 1- 5	
112697-0-01	K -17		115177-0-01	R -18		141748-0-01	H -37		144683-0-01	B -19-1-12	
112698-0-01	L - 4		115249-0-01	M-94		142002-0-01	Z - 4-11			B -19-5- 1-14	
112699-0-01	K -20		115287-0-00	K -29		142037-0-00	U - 1- 3- 5		144685-0-01	B -19-1-17	
112700-0-01	K -21		115638-0-04	E -37			U - 1- 4- 4		144686-0-01	B -19-1-18	
112701-0-01	K -22-1		116010-0-01	D-13		142038-0-01	U - 1- 3- 6		144687-0-01	B -19-1-19	
112702-0-01	K -23		116283-0-01	T -12			U - 1- 4- 5		144688-0-01	B -19-1-20	
112706-0-01	B -19-1- 6		116498-0-01	T - 9		142268-0-01	A -19		144689-0-01	B -19-1-21	
112709-0-01	B - 7		116500-0-01	T - 9		142443-0-01	Z - 3- 1		144703-0-01	B -19-1-14	
112712-0-01	B -19-1-13		116502-0-01	T - 9		142721-0-01	Z - 4-12			B -19-5- 1-16	
	B -19-5- 1-15		116507-0-01	T - 7		142746-0-02	G - 8		144704-0-01	B -19-1-15	
112713-0-01	B - 9-2		116509-0-01	T -11		142747-0-02	G - 7		144823-0-01	B - 9-1	
112714-0-00	B -10-1		116510-1-01	T -11		142990-0-01	Z -16-18- 4		144881-1-01	T - 7	
112715-0-01	B -16		116512-0-01	T -11		143488-0-01	U - 4- 1- 6		144882-0-01	T - 7	
112716-0-01	M- 1		116558-0-01	M-76		143489-0-01	U - 1- 3-17		145328-0-01	G - 1-4	
112717-0-01	M- 2		117133-0-01	T - 7			U - 4- 1- 7		145446-0-01	B -19-5- 1- 8	
112723-0-01	M-15		117160-0-01	R -15		143499-0-00	U - 1- 3-16			Z -14-3	
112724-0-01	M-13		117367-0-01	T - 7		143501-0-00	U - 4- 3-16		145502-0-01	G - 9	
112725-0-01	M-10		117369-0-01	T - 7		143519-0-01	U - 4- 3-15		145596-0-01	U - 1-3-11	
112730-0-01	M-11		117963-0-01	Z -14		143520-0-00	Q -82		145946-0-01	Z -45	
112734-0-01	M-20		117969-0-01	Z -14-10		143548-0-00	U - 1- 3-18		146080-0-00	N-22	
112735-0-00	M-21		117970-0-01	Z -14-11			U - 4- 3-10			P - 9	
112735-0-01	M-22		117971-0-01	Z -14-12		143549-0-00	H - 6- 5		146105-0-00	H-31	
112736-0-00	M-23		118170-1-01	F -28			N - 1- 5		146118-0-00	U - 1-3-10	

# INDEX / VERZEICHNIS INDEX / INDICE

Parts No.	Ref. No.	Remark	Parts No.	Ref. No.	Remark	Parts No.	Ref. No.	Remark	Parts No.	Ref. No.	Remark
S00314-0-01	C-11		009710-8-12	M-3		025040-2-33	U-1-4-15		101118-0-01	U-2	
S00315-0-01	E-52			Q-4		025040-3-35	S-2-3-15			U-12	
S00325-0-01	U-1-4-12			Q-62			S-2-3-20		101268-0-02	D-7	
S00336-0-01	U-10		009711-0-12	E-2			S-2-2-15		101572-1-01	Z-3-4	
S00391-0-01	U-4-3-11			M-29			S-2-2-19		101706-0-01	C-9	
S00858-0-01	D-1-8			Q-20		025050-2-33	V-1-5			G-3-2	
S00858-0-02	D-1-8			Q-60			Z-16-20			J-21	
S00858-0-03	D-1-8		009711-4-12	E-20		025060-1-32	J-17			L-20	
S00896-0-00	Q-84			H-12		025060-2-36	V-1-11		102571-0-03	P-12	
S00897-0-00	Q-84-1			N-17		025630-1-32	Q-12		102731-0-04	D-1-5	
S00899-0-00	Q-84-2			Q-46		025680-1-33	Z-47		102843-0-04	D-1-16	
001061-6-06	V-1-10			Q-48		025710-2-32	E-7		104478-0-01	D-18	
001630-4-02	Q-11			S-3			E-9		104908-0-04	F-24	
001660-5-12	D-1-21			S-5			F-34			J-14	
	M-98		009711-6-12	F-35			K-28		105161-0-02	K-18	
001670-6-12	M-64		009761-4-12	J-16		025750-1-32	Z-24-4-6		105161-0-03	P-14	
002303-0-06	U-5		009781-8-12	D-9		028030-2-43	U-7		105234-0-03	M-58	
002400-8-03	Q-19			G-39		028040-2-43	U-1-4-14		105248-0-03	E-55	
002401-4-02	U-1-4-13		009782-5-12	F-48			V-1-8		105351-0-02	D-4	
002501-0-03	U-1-3-14			H-17		028050-2-43	U-1-3-15			K-26	
005671-2-12	L-7		011679-3-12	E-30-1			Z-16-9		106030-0-01	F-30	
007401-0-12	N-2			E-30-2		028060-2-42	V-1-12		106640-0-01	M-18	
007500-6-02	F-51		011802-0-12	Q-38		028350-2-42	E-56		107030-0-01	D-1-3	
	H-32		013660-4-12	T-1-2		028680-2-42	M-56		107155-0-01	M-78	
007500-8-02	H-18		013710-7-12	F-42			Z-24-4-4		107272-0-02	E-25	
007501-0-03	Z-16-15		013760-6-10	F-3		031452-2-03	Z-16-2			E-35	
009660-4-12	M-90		013761-4-10	C-3			Z-16-17		107278-0-02	J-18	
009670-5-12	E-5			C-13		047301-8-42	E-11-3		107404-0-01	T-6	
	M-6			C-17		047501-2-42	F-25-4		107407-0-03	N-6	
	M-27			C-24		048030-3-42	E-8			N-13	
	M-32			G-14		048040-3-42	E-4		107415-0-14	D-14	
	M-34-1			J-2			F-38			Z-7	
	M-34-2			J-6			H-8		107415-0-22	D-14	
	M-36		013771-2-12	C-21			P-8			Z-7	
	M-36-2			L-9		048060-3-42	G-37		107794-0-01	K-5	
	M-38		013780-7-10	L-5		048070-3-42	G-13			K-8	
009670-6-12	A-10		014760-6-22	G-28		048090-3-42	N-1-3		108254-0-01	B-19-1-4	
	A-20			H-10		071063-5-50	E-18			B-19-5-1-4	
	A-22		014770-6-22	Q-15		072620-4-60	C-18		108263-0-01	B-19-1-7	
	B-8			Q-44		081016-0-70	M-77		108265-0-01	B-19-1-10	
	E-33		015771-0-12	G-26		100022-0-05	Q-55			B-19-5-1-11	
	M-9			H-3		100032-0-04	T-8		108266-0-01	B-12	
009670-8-12	A-8		015771-2-12	C-20		100043-0-03	E-38		108546-0-01	G-27-2	
	F-5			L-10		100064-0-02	B-6		108549-0-01	M-92	
	K-19		017502-8-03	Z-16-7			Q-39		108960-0-02	B-13	
009671-0-12	E-41			Z-16-19		100105-0-05	D-1-8-12			B-15	
009679-3-12	M-12		018061-6-22	Q-2		100197-0-02	K-25			B-17	
	N-8		021060-2-06	V-1-13		100242-0-03	M-62			B-22	
	Z-14-22		021300-1-03	U-6		100248-0-01	M-69			B-24	
009680-6-13	Z-46		021400-1-06	U-1-4-16		100250-0-01	C-5		109268-0-01	V-1-14	
009680-7-12	E-46		021500-1-03	Z-16-4-3		100251-0-01	C-10		109714-0-00	M-71	
	F-9-1-2			Z-16-10			L-18			Z-40	
	F-9-2-2			Z-16-16		100289-0-03	Q-28		110161-0-06	K-12	
	L-13		021500-1-04	V-1-4		100320-0-02	K-3		110171-0-01	H-14	
	S-7		021660-1-02	J-19			K-24			R-10	
009680-8-12	Z-24-4-3		021670-1-02	B-19-1-22		100328-0-01	G-10		110735-0-01	E-50	
009681-0-12	A-4			B-19-5-7		100366-0-02	Z-14-13		112072-0-01	G-21	
	B-11			E-57		100401-0-01	Z-14-4		112560-0-03	A-2	
	G-1-3			R-20		100477-0-01	Z-11-1		112561-0-02	A-5	
	P-7		025030-1-35	S-2-3-13		100645-0-03	H-54		112566-0-03	A-9	
009681-2-12	E-51			S-2-2-11			M-57		112569-0-01	Z-37	
009681-4-12	P-11		025030-2-33	U-8		100657-0-01	Z-14-15		112572-0-01	C-1	
009681-6-12	A-3		025030-3-35	S-2-3-4		100659-0-01	Z-14-17		112573-0-01	C-2	
009710-8-12	E-15			S-2-2-4		100662-0-01	Z-14-20		112576-0-01	C-7	
	E-49		025040-1-35	S-2-3-17		100666-0-02	Z-15		112586-0-01	C-22	
	F-50			S-2-2-13			Z-24-4-5		112594-0-01	D-2	
	G-31		025040-2-32	N-3		100887-0-01	Z-4-1		112595-0-00	D-3	

Parts No.	Ref. No.	Remark	Parts No.	Ref. No.	Remark	Parts No.	Ref. No.	Remark	Parts No.	Ref. No.	Remark
150371-0-01	K- 9- 1		154514-0-01	E-54		159814-0-00	U- 1- 3- 2		158756-0-01	T-11	
150374-0-00	M- 4		154702-0-01	Z-13		159889-0-01	U- 1- 4- 1		158764-1-01	B-19- 5	
150553-0-03	B- 2		154729-0-01	H- 6-2		159890-0-01	U- 1		159801-0-01	K- 9- 3- 3-7	
150557-0-01	Z-36- 3		154730-0-01	H- 6-3		159892-0-00	U- 4- 3- 5		159802-0-01	K- 9- 3- 3-8	
150815-0-01	A-24		154731-0-00	H- 6-4		159893-0-00	U- 4- 3- 6				
150816-0-01	D- 1-10		154732-0-01	H- 6		159894-0-00	U- 1- 4- 7				
150817-1-01	D-19		154734-0-01	H- 6			U- 4- 3- 7				
150818-0-01	E-14		155447-1-01	F-21		159900-0-01	Q-16				
150819-0-01	E-16		155451-0-01	G-35-2		159895-0-01	U- 4- 3				
150820-0-01	E-17		155491-0-01	B-19-5-1- 3		180157-0-01	C-19				
150821-1-00	Q-10		155492-0-01	B-19-5-1-10		180164-0-01	L- 8				
150825-0-01	M-51		155505-0-01	F-16		180321-0-01	G- 3				
150830-0-01	T- 1		155510-0-01	B-19-5-6		180949-0-01	L-16				
150843-0-01	T- 1		155722-0-01	T- 7		180950-0-01	F- 9- 1				
150844-0-01	T- 1		155724-0-01	T- 7		181486-0-01	L-14				
150845-0-01	T- 1		155851-0-01	T- 7		181712-0-01	Q-29				
150846-0-01	T- 1		155853-0-01	T- 7		181713-0-01	Q-31				
150850-0-01	T- 7		155855-0-01	T- 7		183180-0-01	T- 1				
150885-0-01	T- 1		155857-0-01	T- 7		200190-0-01	U- 3				
150917-0-01	D-22		156362-0-01	H- 1		212251-0-01	V- 1- 7				
151007-1-01	M-70		156479-0-00	P-10-2		215080-0-01	S- 2- 2-14				
151025-0-01	K- 9- 1- 3-4		156530-0-01	T- 1			S- 2- 2-20				
151029-0-01	K- 9- 1- 3-5		156546-0-01	N- 1		215083-0-01	S- 2- 3- 5				
	K- 9- 3- 3-5		156548-0-01	P- 4			S- 2- 2- 5				
151030-0-01	K- 9- 1- 3-6		156550-0-01	Q-16			S- 2- 2-12				
	K- 9- 3- 3-6		156816-0-01	T- 7			S- 2- 3-14				
151041-0-01	K- 9- 1- 3		156818-0-01	T-11		216248-0-01	Q-83				
151043-0-01	K- 9- 3- 3-4		156819-0-01	T- 9		216323-0-01	U- 1- 4- 9				
151080-0-01	G-24		156824-0-01	F-25		216324-0-01	U- 1- 4-10				
151081-0-01	J-11		156956-0-01	G-40		216382-0-01	U- 4- 3- 9				
151082-0-01	L- 1		156998-0-01	P- 6		216384-0-01	U- 4- 3- 8				
151083-0-01	M-28- 1		157999-0-01	P-13		217093-0-01	S- 2- 2-16				
151084-0-00	M-42- 1		158747-0-01	G-11-2			S- 2- 3-16				
151147-0-01	U- 1- 3- 4		158748-0-01	G-22-2			S- 2- 3-18				
151153-1-01	U- 1- 3- 1		158749-0-01	C-16			S- 2- 3-21				
151191-0-01	D-20		158750-0-01	L- 1		219557-0-00	S- 2- 3- 6				
151507-0-01	G- 6		158751-0-01	Q-47			S- 2- 2- 6				
151601-0-02	F-25- 2		158752-0-01	H-16		219558-0-00	S- 2- 3- 7				
151602-0-01	G-16		158753-0-01	H-15			S- 2- 2- 7				
	G-41		158761-0-01	K- 9-3		219559-0-00	S- 2- 3- 8				
151602-0-02	A-15		158769-0-01	B-19-5-1-17			S- 2- 2- 8				
151605-0-01	F-27		158770-0-01	B-19-5-3		221421-0-01	S- 2- 3- 9				
	G-35- 1- 2		158771-0-01	B-19-5-2			S- 2- 2- 9				
	G-35- 2- 2		158772-0-01	Q-13		221786-0-01	U- 4- 3-14				
	L-19		158775-0-01	S- 6		222370-0-01	S- 2				
151626-0-01	E-53		158776-0-01	S- 8		224357-0-01	S- 2- 3				
153064-0-01	E-24- 2		158782-1-01	B-19-5-5		503093-0-01	M- 8				
153065-0-01	E-26- 2		158812-0-01	Q-16							
153066-0-01	E-23- 2		158814-0-01	Q-26		800880-0-01	K- 9- 3- 1				
153067-0-01	E-40		158815-0-01	N- 1		S01327-0-01	H-55				
153068-0-01	E-42		158817-0-00	P- 4		S01328-0-01	H-56				
153069-0-01	E-43		159361-0-01	G- 4		100136-0-02	Z-14- 5				
153073-0-02	E-45		159362-0-01	Q- 3		100656-0-01	Z-14-14				
153168-0-01	G- 5		159365-0-01	Q- 5		107231-0-02	A- 6				
153243-0-01	K-36		159366-0-01	Q-41		108264-0-01	B-19- 1- 8				
153244-0-01	K-36		159429-0-01	H- 5		117281-0-01	T- 9				
153433-0-00	U- 4- 3-12		159436-0-01	F-23		149311-0-01	T- 9				
153483-0-01	K-15		159605-0-01	F-33		149312-0-01	T- 9				
153604-1-01	D- 1- 6		159606-0-01	F-47		151027-0-01	K- 9- 1- 1-9				
153606-0-01	D- 1- 7		159607-0-01	F-49			K- 9- 3- 1-9				
153969-0-00	E-58		159608-0-01	F-52		151034-0-01	K- 9- 1- 3-2				
	Q-80		159621-0-01	F-31			K- 9- 3- 3-2				
153971-0-01	E-59		159803-0-01	K- 9-3-3		151035-0-01	K- 9- 1- 3-3				
	Q-81		159805-0-01	B-19-5-1- 9			K- 9- 3- 3-3				
154309-0-00	U-11		159806-0-01	P- 1		151039-0-01	K- 9- 1				
154491-0-01	E-44		159807-0-01	P-10		151040-0-01	K- 9- 1- 2				
154498-1-01	E-47		159813-0-01	U- 1-3		151042-0-01	K- 9- 3- 2				

Parts No.	Ref. No.	Remark	Parts No.	Ref. No.	Remark	Parts No.	Ref. No.	Remark	Parts No.	Ref. No.	Remark
146124-0-01	P-5		148561-1-01	Q-18		148737-0-01	M-85-2		149687-0-01	T-9	
146141-0-01	C-6		148573-0-01	Q-42		148738-0-00	M-84-2		149689-0-01	T-9	
146153-0-01	F-37		148574-0-01	Q-14		148740-0-00	M-41-2		149691-0-01	T-11	
146160-0-01	U-4-1			Q-43		148741-0-01	M-40-2		149692-0-01	T-11	
146175-0-01	V-1		148575-0-01	Q-45		148742-0-00	M-39-2		149697-0-01	Q-49	
146178-0-01	V-1-2		148579-0-01	Q-57		148743-0-01	M-95		149768-0-01	F-18-2	
146358-0-01	V-1-15		148581-0-01	Q-49		148762-0-01	M-63		149819-0-03	A-7	
146597-1-01	E-22		148584-0-01	Q-49-2		148764-0-01	H-26		149820-0-00	C-4	
147189-0-01	U-10-5		148585-0-01	Q-49		148768-0-01	R-13		149821-0-01	C-8	
147191-0-00	U-10-5-2		148587-0-01	Q-51		148770-1-01	N-16		149823-0-01	C-11	
147856-0-02	Z-24-4-1		148589-0-01	Q-52		148771-0-01	G-1		149824-0-01	C-12	
147858-0-01	Z-24-4-2		148591-0-01	Q-53		148801-0-01	G-32-2		149825-0-01	C-14	
147908-0-01	Z-24		148592-0-01	Q-54		148802-0-01	G-35-1		149826-0-01	B-23	
148005-0-01	K-11		148599-0-01	D-12		148803-0-01	L-8		149827-0-01	D-1-8-6	
148011-1-01	B-19-1		148601-0-01	K-33		148804-0-01	L-14		149831-0-01	T-3	
148462-0-01	A-21		148603-0-01	K-27-2		148818-0-01	A-21		149832-0-01	T-5	
148480-0-01	K-22-2			Z-9		148821-0-01	L-10		149833-0-01	T-4	
148481-0-01	K-1-2		148604-0-00	B-10-2		148825-0-01	S-4		149834-0-00	M-96	
148482-1-01	Q-1		148605-0-01	F-53		148835-0-01	F-9-1		149837-0-01	E-1	
148483-0-01	F-6		148607-0-02	H-2			F-9-2		149838-0-01	E-3	
148486-0-01	F-14-1		148608-0-01	H-4		148882-0-01	Z-36-1		149839-0-01	E-6	
	F-14-2		148611-0-01	A-16		148890-1-01	Z-39		149843-0-01	E-10	
148487-0-01	G-17		148614-0-01	A-17		148924-1-01	B-19-1-9		149847-0-01	E-11	
148488-0-01	G-12		148615-0-01	S-1		148977-0-01	J-12		149852-0-01	E-12	
148489-0-01	G-11-1		148619-0-01	R-1		149001-0-01	J-7		149853-0-01	E-13	
148490-0-01	J-11		148623-0-01	R-2		149010-0-00	Z-11-2			E-48	
148491-0-01	J-12		148625-0-01	R-5		149024-0-01	F-39		149855-0-01	E-19	
148492-0-01	J-7		148628-0-01	R-6		149025-0-01	F-43		149856-0-01	E-21	
148493-0-01	J-1			R-9		149027-0-01	F-45		149857-0-01	E-23-1	
148494-0-01	J-5		148629-0-01	R-7		149063-0-01	H-42		149858-0-01	E-24-1	
148495-0-01	G-38		148630-0-01	R-8		149169-0-01	Q-8-2		149859-0-01	E-26-1	
148496-0-00	G-32-2-1		148631-0-01	R-11		149174-0-01	H-7		149860-0-01	E-27	
148500-0-01	G-18		148632-0-01	R-12		149177-0-01	D-23		149863-0-01	E-28	
148501-1-01	G-15-2		148633-0-01	R-17			N-21		149864-0-01	E-29-1	
	G-15-3		148634-0-01	R-14		149179-0-01	A-23			E-29-2	
148502-0-00	L-3		148635-0-01	R-16		149288-0-02	A-18		149865-0-01	E-31	
148503-0-00	L-2		148638-0-01	H-9		149554-0-01	H-53		149866-0-02	E-32	
148508-0-01	N-15		148640-0-01	H-11		149604-0-01	D-1-8-4		149867-0-01	E-34	
148511-0-01	N-1-2		148654-0-01	R-19		149605-0-01	D-1-8-5		149868-0-01	E-36	
148512-0-00	N-1-4		148655-0-01	Q-61		149606-0-01	D-1-8-7		149873-0-01	P-2	
148513-0-02	N-5		148674-0-01	F-29		149607-0-01	D-1-8-8		149938-0-01	T-11	
148514-0-02	N-7		148681-0-01	T-9		149608-0-01	D-1-8-9		149939-0-01	T-11	
148515-0-01	N-9		148683-0-01	T-9		149609-0-01	D-1-8-11		149940-0-01	T-9	
148516-0-01	N-11		148685-0-01	T-9		149610-0-01	D-1-8-13		149942-0-01	T-9	
148517-0-00	N-12		148687-0-01	T-9		149611-0-01	D-1-8-14		149948-0-01	T-11	
148518-0-00	N-14		148689-0-01	T-9		149612-0-01	D-1-8-15		149949-0-01	T-11	
148521-0-01	N-10		148691-0-01	T-9		149613-0-01	D-1-9		149950-0-01	T-9	
148526-0-01	N-18		148693-0-01	T-9		149614-1-01	D-1-11		149952-0-01	T-9	
148527-0-01	N-18		148695-0-01	T-9		149615-1-01	D-1-12		149954-0-01	T-7	
148528-0-01	N-23		148698-0-01	T-11		149616-0-01	D-1-13		149958-0-01	Q-49	
148529-0-01	N-19		148699-0-01	T-11		149617-0-01	D-1-15		149986-0-01	N-23	
	Z-33		148700-0-01	T-11		149618-0-02	D-1-17		149991-0-01	F-46	
148530-0-01	N-20		148701-0-01	T-11		149618-0-03	D-1-17		150106-0-01	Z-16-4	
	Z-34		148702-0-01	T-11		149618-0-04	D-1-17		150139-0-01	Z-16-1	
148536-0-01	Q-6		148703-0-01	T-11		149618-0-05	D-1-17		150151-0-03	Z-16	
148537-0-01	Q-7		148704-0-01	T-11		149618-0-06	D-1-17		150172-0-01	Z-16-3	
148538-0-01	Q-8-1		148705-0-01	T-11		149618-0-07	D-1-17		150176-0-01	Z-16-6	
148539-0-01	Q-9		148728-0-01	M-59-2		149618-0-08	D-1-17			Z-16-18-1	
148545-0-01	Q-16-3		148729-0-01	M-28-2		149618-0-09	D-1-17		150179-0-01	Z-16-8	
148546-0-01	N-4		148730-0-01	M-24-2		149618-0-10	D-1-17		150180-0-00	Z-16-11	
	Q-17		148731-0-00	M-25-2		149618-0-11	D-1-17		150181-1-01	Z-16-1-2	
148547-0-01	Q-21		148732-0-01	M-30-2		149621-0-01	D-1-18		150182-0-00	Z-16-12	
148548-0-01	Q-22		148733-0-01	M-42-2		149622-0-01	D-1-19		150184-0-01	Z-16-18-5	
148554-0-01	Q-27			M-50-2		149623-0-01	D-1-20		150188-0-01	Z-16-14	
148555-0-01	Q-25		148734-0-00	M-49-2		149624-0-01	D-1-22		150193-0-03	Z-16-18	
148557-0-01	Q-30		148735-0-01	M-44-2		149625-0-01	D-1-23		150202-0-01	Z-16-4-2	
148559-0-00	Q-24		148736-0-00	M-43-2		149626-0-01	M-97		150369-1-01	D-1	

